

Tom Schwartz
Aug. 23/06

885282

82KNW004
087

TECHNICAL REPORT
on the
MAX MOLYBDENUM PROPERTY

**Revelstoke Mining Division
British Columbia, Canada**

**Prepared for
ROCA MINES INC.**

September 20, 2004
Vancouver, BC

T. N. Macauley, P.Eng.

EXECUTIVE SUMMARY

Roca Mines Inc. ('Roca') has acquired an option to earn a 100% interest in a property in southeastern British Columbia that contains a significant molybdenum deposit. Adjacent claims have been staked and purchased, so that Roca has now consolidated its control of the area of interest.

The MAX property was previously explored by a joint venture of Newmont Mines Limited ('Newmont') and Esso Minerals Canada ('Esso') in 1975 to 1982 as their Trout Lake Project. Work expenditure during that period totalled \$14.9 million. Roca has recently purchased from Newmont the complete original data set documenting the results of that work.

Geologically, the property lies near the north end of the Kootenay Arc in tightly folded, strongly sheared metasedimentary rocks of Paleozoic age. On the MAX property these rocks are intruded by a small granodiorite stock of Cretaceous age, with which molybdenite mineralization is associated. A pipe-like mineralized body has been traced by extensive diamond drilling from its small surface exposure on a mountain ridge downward to where it swells out into a substantial deposit.

At 500 m below the surface showing, the Newmont-Esso joint venture drove a long adit to the deposit, and carried out drifting and crosscutting within it. Radiating diamond drill holes from underground delineated the central portion of the deposit, where its extent at that horizon is about 200 by 300 m. Deeper exploratory drilling showed the body developed a steep southwesterly plunge below the adit level. Mineralization was traced as deep as 1000 m below surface where it remains open to extension.

Molybdenite (MoS_2) is the only mineral of economic importance in this deposit. Along with pyrite and pyrrhotite, the total sulphide content is 1 to 2%, but runs as high as 10 to 15% in the higher grade zones. Molybdenite is mainly present along the margins of veins in a quartz stockwork. In the higher grade zones (>1% MoS_2) it is strongly disseminated in microfractured intrusive bodies accompanied by large quartz veins and intense quartz flooding. The vein stockwork is best developed in and around the margins of the intrusive and its dyke-like apophyses. The centre of the large granodiorite mass is virtually devoid of veining and mineralization. Faulting is evident in and around the deposit, some probably pre-mineralization. A strong post-mineral fault bounds the east side of the deposit.

Several long inclined diamond drill holes from surface into the central portion of the deposit produced exceptional results. For example, hole 77-3 averaged 0.408% MoS_2 over 271 m. Following that up, three more intersections in the same vicinity obtained averages of 0.225 to 0.443% over lengths of 276 to 349 m. Within these long intersections were a number of 10 to 30m lengths of better grade material in the 0.5 to 1.0% range plus a few high grade ones, the best of which was 23m of 3.077%. The latter contained the highest individual sample of

1.5m containing 7.19%. The later underground program showed these to be in the largest of the five zones comprising the deposit, where dyking, veining, faulting is most intense. The mineralization continues to depth to the southwest, but has not been drilled to the same degree because of the hole depths and inadequate drill positions.

The mineral resource estimate of the Newmont-Esso joint venture has been reviewed and modified by the author, as follows, to bring it into compliance with the CIM Standards stipulated by National Instrument 43-101 of the Canadian Securities Commissions.

MEASURED			INDICATED		MEASURED & INDICATED	
Cutoff % MoS ₂	Tonnes	Grade % MoS ₂	Tonnes	Grade % MoS ₂	Tonnes	Grade % MoS ₂
0.10	27,870,000	0.21	15,070,000	0.18	42,940,000	0.20
0.20	9,340,000	0.35	2,010,000	0.41	11,350,000	0.36
0.50	1,010,000	1.01	370,000	0.77	1,380,000	0.94
1.00	260,000	1.95	20,000	1.87	280,000	1.95

In addition to the above, inferred resources total 8,900,000 tonnes averaging 0.16% MoS₂ at the 0.10 cutoff, including 460,000 tonnes averaging 0.33% at the 0.20 cutoff. The resource was estimated manually by drawing grade contours at the 0.10, 0.20, 0.25, 0.50, 1.00% MoS₂ levels on the 30 m spaced sections, and then dividing the material bounded by the contours into polygons, generally based on one or several drill intercepts. Bulk sampling of the drift rounds confirmed the grades of diamond drill holes and grade contours in those areas. No allowances for mining losses or dilution are incorporated in these estimates.

Metallurgical testing of drill core composites recovered about 90% of the molybdenite in a concentrate assaying 90 to 92% MoS₂ in bench scale flotation tests. Testing of adit bulk sample composites detected a grade versus recovery relationship that warrants further investigation.

Environmental studies during the 1979 – 1982 period collected valuable information, and Newmont's consultants concluded that development of a molybdenite mine could likely be accomplished without serious detrimental effects to the existing environment of the area provided that mitigative measures were incorporated during all phases of development. Sites for a possible plant and tailings storage are conveniently located on the property below the adit portal.

Work on the project was suspended by the Newmont-Esso joint venture in 1982 due to a price decline and poor market projection for molybdenum products. After languishing in the US \$2 to \$4 per pound range for most of the time since then, the price of molybdenum in

oxide form started to climb in 2003 and is currently trading at US \$17.25 to \$18.50 per pound.

It is concluded that the attributes of this project justify its economics being analysed at several grade/tonnage combinations. One of these should involve a mining plan for the resource at the 0.50% MoS₂ cutoff, which would not require a mill of large tonnage capacity. The study of the larger resource at the 0.20% cutoff should determine what additional drilling and studies are needed for an operational plan. It should likely include some drilling on the exploration targets that have been described.

The program being recommended here is to re-establish access to the adit, and then carry out 3000 m of detailed diamond drilling on the portion of the large B Zone known as the High Grade Dyke (HG Zone). At this locality, 706,000 tonnes averaging 1.07 % MoS₂ are estimated in a vertical body 60 to 90 m long, 235 to 335 m high and 7 to 28 m wide. The program consisting of about 23 holes would bring drill hole spacing in the upper portion of the zone to about a 20 m grid. This would permit development of a mining plan using ramp access from the existing adit. The estimated cost of the program is \$975,000.

TABLE OF CONTENTS

EXECUTIVE SUMMARY	I
TABLE OF CONTENTS.....	IV
TABLES.....	V
FIGURES	V
INTRODUCTION.....	1
PROPERTY DESCRIPTION AND LOCATION	1
ACCESS, INFRASTRUCTURE, PHYSIOGRAPHY	7
HISTORY	7
GEOLOGICAL SETTING.....	9
Regional Geology.....	9
Property Geology.....	9
Structure	10
Metamorphism & Alteration	10
DEPOSIT TYPES.....	13
MINERALIZATION.....	13
EXPLORATION	17
Geological Work	17
Geochemistry and Geophysics.....	17
Underground Exploration Program.....	17
DRILLING	18
Due Diligence Surface Drilling by Roca Mines Inc.	19
SAMPLING METHOD AND APPROACH	21
Diamond Drilling	21
Bulk Sampling.....	21
SAMPLE PREPARATION, ANALYSES, SECURITY	23
DATA VERIFICATION	23
MINERAL PROCESSING & METALLURGICAL TESTING.....	24
MINERAL RESOURCE ESTIMATE	27
Estimation Method.....	27
Resource Categorization	32
MINING STUDY	32
ENVIRONMENTAL CONSIDERATIONS	33
INTERPRETATION AND CONCLUSIONS	33
General.....	33
Exploration Targets	34
RECOMMENDATIONS.....	35
Cost Estimate	36
REFERENCES.....	37
CERTIFICATE OF AUTHOR	39

TABLES

Table 1 – MAX Property Claims	5
Table 2 – Summary of Diamond Drilling.....	18
Table 3 – Analyses of Roca Drill Core	20
Table 4 – Summary of Metallurgical Results 1979 – 1980.....	25
Table 5 – Summary of Results – Adit Samples – 960 Level	26
Table 6 - MAX Property – Mineral Resources By Zone	29
Table 7 – MAX Property – Total Mineral Resources	30

FIGURES

Figure 1 - Location Map	2
Figure 2 – Property Map.....	4
Figure 3 – Regional Geology Map.....	11
Figure 4 – Surface Geology Map	12
Figure 5 – 960 m Level Plan	14
Figure 6 – Section A-B	16
Figure 7 – Bulk Sampling Flowsheet.....	22
Figure 8 – Resource Polygons – Section 8	31

INTRODUCTION

Roca Mines Inc. ('Roca') has acquired an option to earn a 100% interest in certain mineral claims in southeastern British Columbia that contains a significant molybdenum deposit. Adjacent claims, crown grants and a mining lease have been staked and purchased, such that Roca has now consolidated its control of the area of interest.

The MAX property was previously explored by a joint venture of Newmont Mines Limited ('Newmont') and Esso Minerals Canada in 1975 to 1982 as their Trout Lake Project. Work expenditures during that period totalled CDN \$14.9 million. Roca has recently purchased from Newmont Mines Limited the complete set of data documenting the results of that work.

The author of this report has been retained by Roca to conduct the following tasks:

- review the extensive data base of past work on this property;
- review and modify where necessary the historic mineral resource estimate;
- assess the potential of the mineral deposit in light of current conditions; and
- make recommendations on work to be done to further advance this project.

This technical report has been prepared in compliance with National Instrument 43-101 *Standards of Disclosure for Mineral Projects* and Form 43-101 F1 of the Canadian securities commissions. It is intended to be used for filing, if required, with the British Columbia Securities Commission and the TSX Venture Exchange.

The sources of information used in the preparation of this report are principally the private reports, maps, drill logs, acquired from Newmont. The Final Report by Boyle & Parliament dated January 1983 summarizes all the facets of the project by Newmont staff and outside consultants. The main published sources are the papers by Boyle & Leitch (1983) and Linnen et al. (1995) in publications of the Canadian Institute of Mining, Metallurgy and Petroleum (CIM).

The author's familiarity with this property derives from doing the initial geological mapping and geochemical survey in 1975 for Newmont Exploration of Canada, and then as exploration manager directing the exploration and data compilation in the 1976-1982 period. He last visited the property on August 20, 1991, in company with an environmental specialist, when he inspected the stockpiled mineralized rock, the adit portal area, an adjacent historic shaft known as the Lucky Boy and the condition of the stored drill core.

Monetary amounts referred to in this report are Canadian dollars unless otherwise specified.

PROPERTY DESCRIPTION AND LOCATION

The property is located in the Revelstoke Mining Division at longitude 117° 36' W and latitude 50° 38' N on National Topographic System map sheet 82K/12E as shown on Figure 1. Its area is approximately 45 square kilometres (27 square miles).

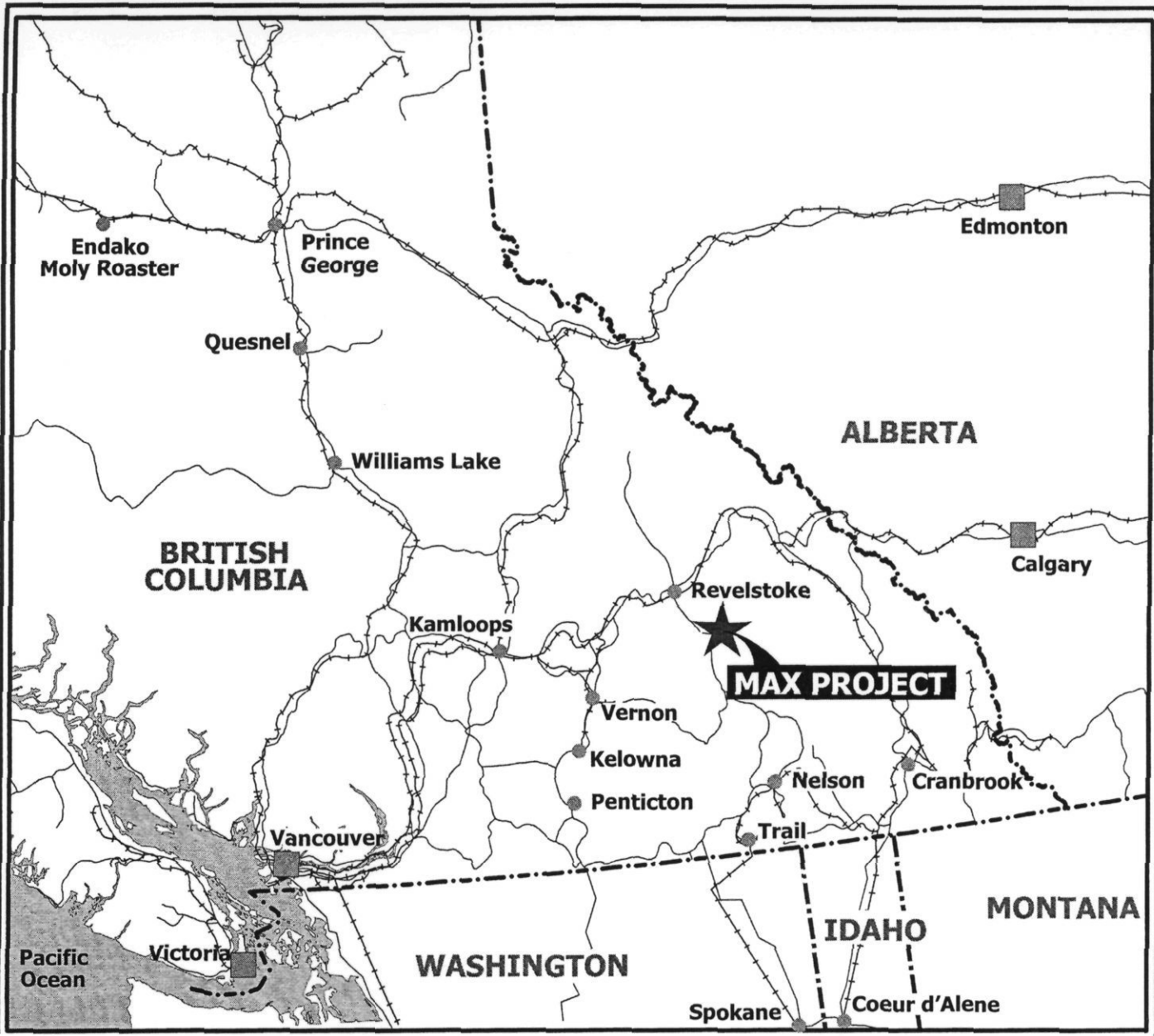

SCALE 1:5,000,000

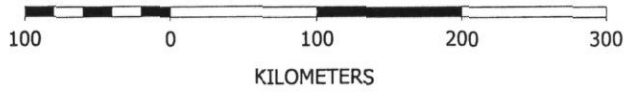

- Railways
- Highways

PROJECT				MAX MOLYBDENUM PROJECT			
TITLE				LOCATION MAP			
DATE	AUGUST 2004	SCALE	1:5,000,000	DRAWN	WKL		
PROJECT No.	0327-003-01	FIGURE No.	1	REV.	0		



Roca Mines Inc.

The property consists of 64 mineral titles, the particulars of which are listed in Table 1, and shown on Figure 2. The claims are contiguous. The five Crown Granted claims and one Mining Lease have been legally surveyed, and carry surface rights when used for mining purposes. They are maintained by paying the nominal land tax and lease payment annually. The others are located mineral claims carrying mineral rights only and must be kept in good standing by filing evidence of having done the required assessment work or paying cash in lieu thereof. Although not legally surveyed, their location shown on Figure 2 is believed to be accurate. In addition, the purchase from Newmont includes a Licence of Occupation No. 402602 for a portion of District Lot 7951.

Referring to Figure 2, it should be noted that the mineral deposit is centrally located within the property on claims CCM #1, CCM #2, CCM3, and CCM4, and the potential plant site and tailings storage area lie just downslope from the adit portal on claims CCM5 to CMM8 and portions of MAX 2 and 5.

Emerald Gold Mines Inc. ('Emerald') a private company qualified to do business in British Columbia, has granted Roca an option to acquire a 100% interest in the Emerald Property comprising several claims listed in Table 1, subject to a net smelter return royalty ('NSR'), by:

- a) paying Emerald \$200,000 in stages on or before January 1, 2007 (\$50,000 paid), and
- b) issuing to Emerald 400,000 shares in annual payments of 100,000 shares on or before January 16, 2007 (100,000 issued).

Subject to Exchange policies, Roca shall issue to Emerald a further 200,000 shares at commencement of commercial production. The NSR is at the rate of 2.5% and Roca has the right to purchase up to a 60% interest in NSR by paying \$1,000,000 for each 30% interest. In addition to the Emerald claims, the NSR also applies to any production from other claims acquired by Roca after January 10, 2004 that are situated within 6 km of the perimeter of the Emerald claims.

With regard to the claims, crown grants and mining lease purchased from Newmont (the Newmont Property), Roca has granted Newmont a 2.5% NSR on any production from the Newmont Property, with such NSR being reduced to 1% by Roca paying to Newmont \$2,000,000 prior to commencement of production, at Roca's option. Roca has also agreed to issue to Newmont 200,000 shares on making a production decision on the Newmont Property.

Roca has assumed the future liability of Newmont on the claims it has purchased from them, and also the ground formerly controlled by Newmont now held as the CCM and MAX claims. Roca has indemnified Newmont against third party claims of property damage or injury or death arising out of activities on the purchased claims subsequent to date of purchase, and on the former Newmont ground whether arising prior to or subsequent to the purchase date.

Roca has filed a Notice of Work with the BC Ministry of Energy and Mines ('BCMÉM') to carry out the work program recommended in this report and a response is pending. Roca will have posted a bond with the BCMÉM to cover continuation of water quality testing for three years that was Newmont's reclamation obligation, and will be posting another bond to cover reclamation arising from their own exploration activities.

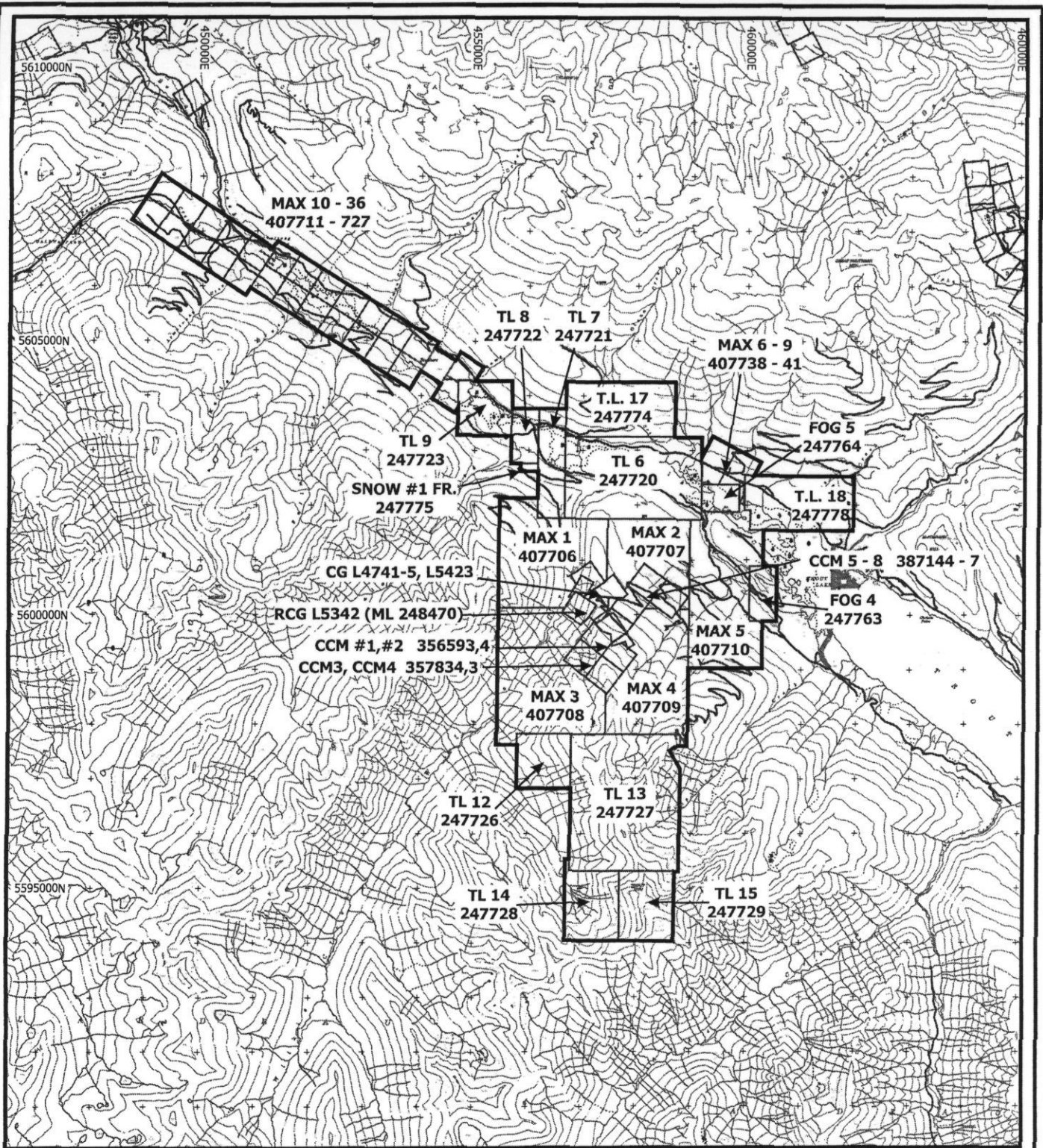

SCALE 1:100,000



KILOMETERS

N

COMPILED FROM BRITISH COLUMBIA MINERAL TITLES
 REFERENCE MAPS m082k052,053,062,063,072,073
 NAD83 UTM ZONE 11N

PROJECT

MAX MOLYBDENUM PROJECT

TITLE

PROPERTY MAP

DATE

AUGUST 2004

SCALE

1:100,000

DRAWN

WKL

PROJECT No.

0327-003-01

FIGURE No.

2

REV.

0



Roca Mines Inc.

Table 1 – MAX Property Claims

Part 1 – The Emerald Property: Optioned from Emerald Gold Mines Inc.

Claim Name	Tenure No.	No. of Units	In Good Standing Until
CCM #1	356593	1	2005.09.29
CCM #2	356594	1	2005.09.29
CCM3	357834	1	2005.09.29
CCM4	357833	1	2005.09.29
CCM5	387144	1	2005.09.29
CCM6	387145	1	2005.09.29
CCM7	387146	1	2005.09.29
CCM8	387147	1	2005.09.29

Part 2 – The Newmont Property: Purchased from Newmont Mines Limited

Claim Name	Tenure No.	No. of Units	In Good Standing Until
TL 6	247720	15	2005.12.01
TL 7	247721	4	2005.12.01
TL 8	247722	2	2005.12.01
TL 9	247723	4	2005.12.01
TL 12	247726	4	2005.02.23
TL 13	247727	20	2005.02.23
TL 14	247728	6	2005.02.23
TL 15	247729	6	2005.02.23
TL 17	247774	8	2005.11.22
TL 18	247778	8	2005.02.21
Fog 4	247763	2	2005.07.31
Fog 5	247764	2	2005.10.12
Snow #1 Fr	247775	1	2005.12.19
Mining Lease (Horseshoe, Lot 5342)	248470	1	2005.08.23
Crown Grants	Lots 4741- 4745,5423	6	2005.07.01

Part 3 – Claims staked by Roca Mines Inc.

Claim Name	Tenure No.	No. of Units	In Good Standing Until
MAX 1	407706	16	2005.09.29
MAX 2	407707	12	2005.09.29
MAX 3	407708	20	2005.09.29
MAX 4	407709	15	2005.09.29
MAX 5	407710	18	2005.01.14
MAX 6	407738	1	2005.01.12
MAX 7	407739	1	2005.01.12
MAX 8	407740	1	2005.01.12
MAX 9	407741	1	2005.01.12
MAX 10	407711	1	2005.01.12
MAX 11	407712	1	2005.01.12
MAX 12	407713	1	2005.01.14
MAX 13	407714	1	2005.01.12
MAX 14	407715	1	2005.01.12
MAX 15	407716	1	2005.01.12
MAX 16	407717	1	2005.01.12
MAX 17	407728	1	2005.01.12
MAX 18	407729	1	2005.01.12
MAX 19	407730	1	2005.01.12
MAX 20	407731	1	2005.01.12
MAX 21	407732	1	2005.01.13
MAX 22	407733	1	2005.01.13
MAX 23	407734	1	2005.01.13
MAX 24	407735	1	2005.01.13
MAX 25	407736	1	2005.01.13
MAX 26	407737	1	2005.01.13
MAX 27	407718	1	2005.01.13
MAX 28	407719	1	2005.01.13
MAX 29	407720	1	2005.01.13
MAX 30	407721	1	2005.01.13
MAX 31	407722	1	2005.01.12
MAX 32	407723	1	2005.01.12
MAX 33	407724	1	2005.01.12
MAX 34	407725	1	2005.01.12

MAX 35	407726	1	2005.01.12
MAX 36	407727	1	2005.01.12

ACCESS, INFRASTRUCTURE, PHYSIOGRAPHY

Access to the MAX property is via Highways 23 and 31 from the towns of Revelstoke (on Trans Canada Highway and CPR mainline) or Nakusp, with driving distance of 80 kilometres (km) to Trout Lake village, then 6 km of logging roads to the adit portal. The Trout Lake valley is sparsely populated and little infrastructure exists beyond road, telephone line and accommodation.

The property extends from the Trout Lake valley at elevation 760 metres (m) (2500 feet) on the north for 8 km south to the peak of Trout Mountain at elevation 2700 m (8800 feet). Slopes are moderate in the northeast portion of the property where most of the exploration has been done, but steep on the west side and the higher ground to the south. Mature hemlock and cedar forest occur below about 1800 m (6000 feet) elevation. Logging in recent years has taken place in the drilling area, and disrupted the former system of drill roads.

Mean annual precipitation in this area is about 500 millimetres (mm) rain (20 inches); snow 3300 mm (130 inches), for a total of 840 mm (33 inches). Mean daily temperatures range from -9°C in January to 15°C in July. The ideal time for surface exploration is May to October.

Various engineering studies by Newmont suggest that infrastructure development of a mine, including camp, mill and concentrator, and tailings storage could be readily accommodated on the MAX property, with arrangements to be made for surface rights as necessary.

HISTORY

The first claims staked in the MAX property area were the Lucky Boy and Copper Chief in 1897 and 1901, with early work focusing on silver bearing quartz veins. Shipments of sorted ore from the Lucky Boy were 450 tonnes (t), with a further 20 t of tungsten ore in 1942. In the early 1950's Major Explorations Limited carried out surface exploration on tungsten-bearing skarns. Although molybdenite was reported as early as 1917, it was not until 1969 that a subsidiary of Scurry Rainbow Oil Limited (Cascade Moly Mines Limited) optioned a claim group covering the area of interest from Mr. Alan Marlow. Later bulldozer trenching and six surface drill holes helped to extend the area of molybdenite mineralization from the small (few square metres) surface showing.

In 1975 Newmont Exploration of Canada Limited optioned Mr. Marlow's property and carried out prospecting, geological mapping and a geochemical survey (Macauley, 1975). In 1976 a

joint venture with Esso Minerals Canada Limited ('Esso') was formed, (The Trout Lake Project), with Newmont being the operator. Surface diamond drilling of 32 holes (15,747 m) from 1976 to 1979 was successful in significantly expanding the molybdenite deposit and demonstrating some better grade sections.

This led to a decision to undertake an underground exploration and bulk sampling program. From 1979 to 1981, a total of 2,000 m of adit, crosscuts and drift development was made on one level (the 960 m level) approximately 500 m below the surface outcrop. Underground diamond drilling of 22,151 m in 87 holes detailed the mineralization and explored the adjacent areas. Bulk samples from 189 drift and crosscut blast rounds over a total length of 687 m were processed through a crushing plant and sampling tower on site. Metallurgical laboratory testing was carried out on both drill core and bulk samples. Preliminary mining, environmental and socio-economic studies sufficient to establish a database for a Preliminary Stage 1 Environmental Assessment, as required to obtain government approval, were then completed.

Following compilation of all data, Newmont staff estimated "geologic reserves" of 48.7 million tonnes averaging 0.193% MoS₂ at a 0.10% cut-off, within which was 11.7 million tonnes of 0.362% MoS₂ at a 0.20% cut-off, or 4.8 million tonnes of 0.481% MoS₂ at a 0.25% cut-off. The estimate was divided into "drill defined" and "drill indicated" categories (Boyle & Parliament, 1983). This estimate is not in compliance with the modern classification system defined by CIM Standards and stipulated by National Instrument 43-101. Those estimates have been reviewed and modified by the author and summaries are provided later in this report.

Further work on the project was halted in late 1982 due to a decline in price and poor market outlook for molybdenum products. Total costs from project inception in 1975 to December 31, 1982 were \$14.9 million. Remaining payments to property vendors were made and Newmont purchased Esso's 45% interest in the property in the early 1990's.

In 1997 claims in the central portion of the property covering the molybdenum deposit expired and were immediately staked by Emerald.

In 2003, Newmont carried out a reclamation program on the Newmont Property and, acting as an agent for the province of British Columbia completed reclamation on the Emerald property. The reclamation work consisted mainly of constructing a water collection and drainage system at the adit portal, closing the adit by placing granular fill at the portal, collecting the mineralized stockpile material, drill core, and wood/metal waste and burying them in the existing concrete ore bins. Final reclamation of this material and the concrete bins included covering them with compacted soil, site grading and vegetating.

On January 16, 2004 Roca optioned the claims covering the deposit from Emerald. In May 2004, Roca conducted a surface diamond drilling program comprising two holes (totalling 1,134 m) on the deposit in an effort to confirm former holes and obtain core samples of representative mineralization as a due diligence exercise.

By agreement effective August 6, 2004, Roca purchased all of Newmont's remaining property and the complete original data set documenting the work of the Newmont-Esso joint venture.

GEOLOGICAL SETTING

Regional Geology

As summarized by Boyle and Leitch (1983) and shown on Figure 3, the property lies near the north end of the Kootenay Arc, a belt of highly deformed, heterogeneous sedimentary rocks bowed around the eastern margin of the Nelson and Kuskanax batholiths, at the south end of the Lower Jurassic Shuswap metamorphic terrace.

The oldest rocks of the district around the property are schists, phyllites, and quartzites, with minor greenstone, of the Lower Cambrian—Middle Devonian aged Lardeau Group. They have been tightly folded and strongly sheared in northwest-trending folds, which are broken into panels by northwest and north-trending faults. Unconformably overlying these rocks are conglomerate, limestone, and sandstone of the Upper Mississippian aged Milford Group. The Jurassic aged Kuskanax Batholith, a monzonite dated at 178 Ma, lies 5 km south of the property. A series of calc-alkaline stocks of Jurassic to Cretaceous age (150-74 Ma) includes the one on the property, which has been dated by K/Ar on biotite at 76.7 ± 2.9 Ma. Molybdenite (molybdenum disulphide or MoS_2) is associated with several of these stocks in the Kootenay – Upper Arrow Lake area.

Property Geology

The Lardeau Group rocks in the vicinity of the deposit are silicified chlorite sericite biotite schists, and lesser argillite, slate, quartzite and hornfels. Carbonate units interbedded with the clastics to the north and south of the deposit are limestone, dolostone, calc-silicate schist and skarn as shown on Figure 4. The latter includes a variety of rocks from calc-silicate hornfels to diopside garnet skarn, frequently with pyrrhotite and occasionally scheelite.

Intruding the above is the Trout Lake stock forming a network of intersecting dykes and irregular masses. There appears to be as many as four intrusive phases, with the earliest porphyritic granodiorite making up the bulk of the stock, followed by aplite dyking, and three varieties of granodiorite and quartz diorite. The dykes are inter-mineral, as they both cut off and are cut by mineralized quartz veins.

The stock measures about 50 to 100 m wide by 300 m long at surface; it has been traced by drilling to a depth of 1000 m where it broadens considerably, but its overall form is unknown.

Structure

The meta-sediments strike northwest and dip 60-90° northeast. They are tightly folded with axes horizontal to moderately plunging. The strong, north-trending, vertical "Z" Fault bounds the stock on its east side and appears to have exerted a control on the location of the stock and subsequent mineralization. A post-mineral, east side down movement is indicated. Other northwest-southeast faults have been mapped or interpreted. Many small conjugate and splay faults cut the deposit underground, but displacements are generally less than 10 m.

Dyke and quartz vein orientation also form conjugate patterns, with northeast and northwest sets as well as north-south sets, shown on Figure 5, and lesser flat-dipping veins. Veining increases toward several centres associated with intrusive apophyses. Flat-dipping veins also become more prevalent along with randomly oriented veins to form a true stockwork (Boyle and Leitch, 1983).

Metamorphism & Alteration

Regional metamorphic grade increases from northeast to southwest approaching the Kuskanax Batholith. A 1.2 by 2 km contact metamorphic aureole about the stock has been recognised, exemplified by biotite hornfels in the pelitic rocks and an assemblage of muscovite – chlorite – tremolite – clinozoisite – plagioclase – k feldspar – quartz in the calc-silicates.

Hydrothermal alteration studies show a strong silica-potassic zone with MoS_2 present at the centre, outward to a quartz-sericite-pyrite (phyllic) zone, and possibly an outer zone where ankerite and chlorite are more prevalent. Molybdenite is strongly associated with alkali feldspars, but in detail is associated with incipient muscovite replacement of albite and K feldspar; veins that lack feldspars are typically barren of molybdenite. This topic is discussed in more detail in Boyle and Leitch (1983) and Linnen et al (1995).

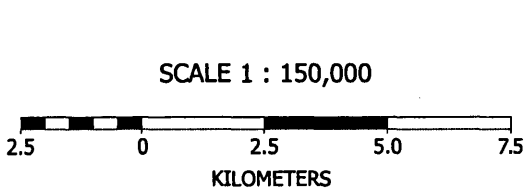
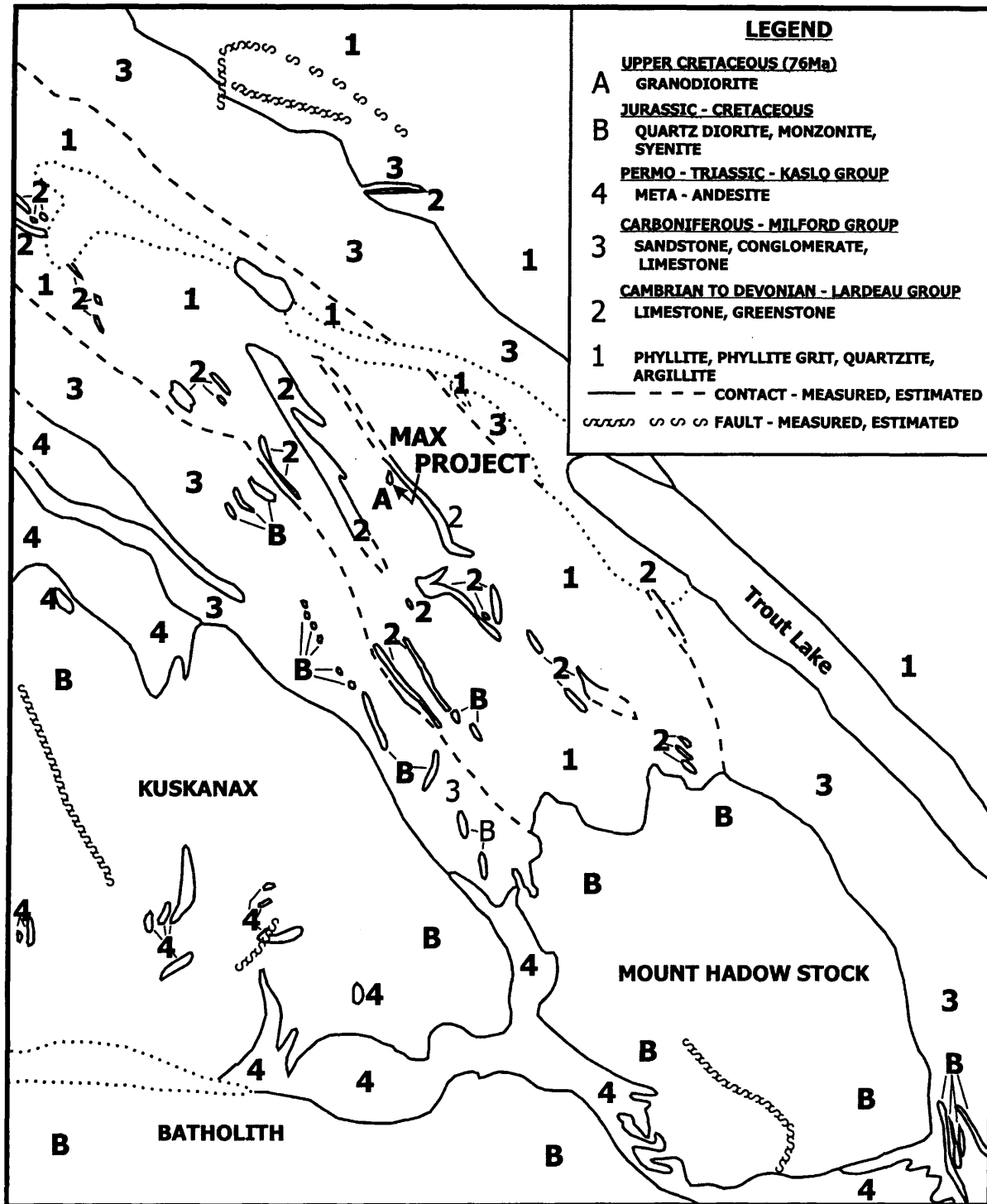

AFTER READ, WHEELER 1976 (GSC)

PROJECT MAX MOLYBDENUM PROJECT			
TITLE REGIONAL GEOLOGY			
DATE AUGUST 2004	SCALE 1:150,000	DRAWN WKL	
PROJECT No. 0327-003-01	FIGURE No. 3	REV. 0	



Roca Mines Inc.

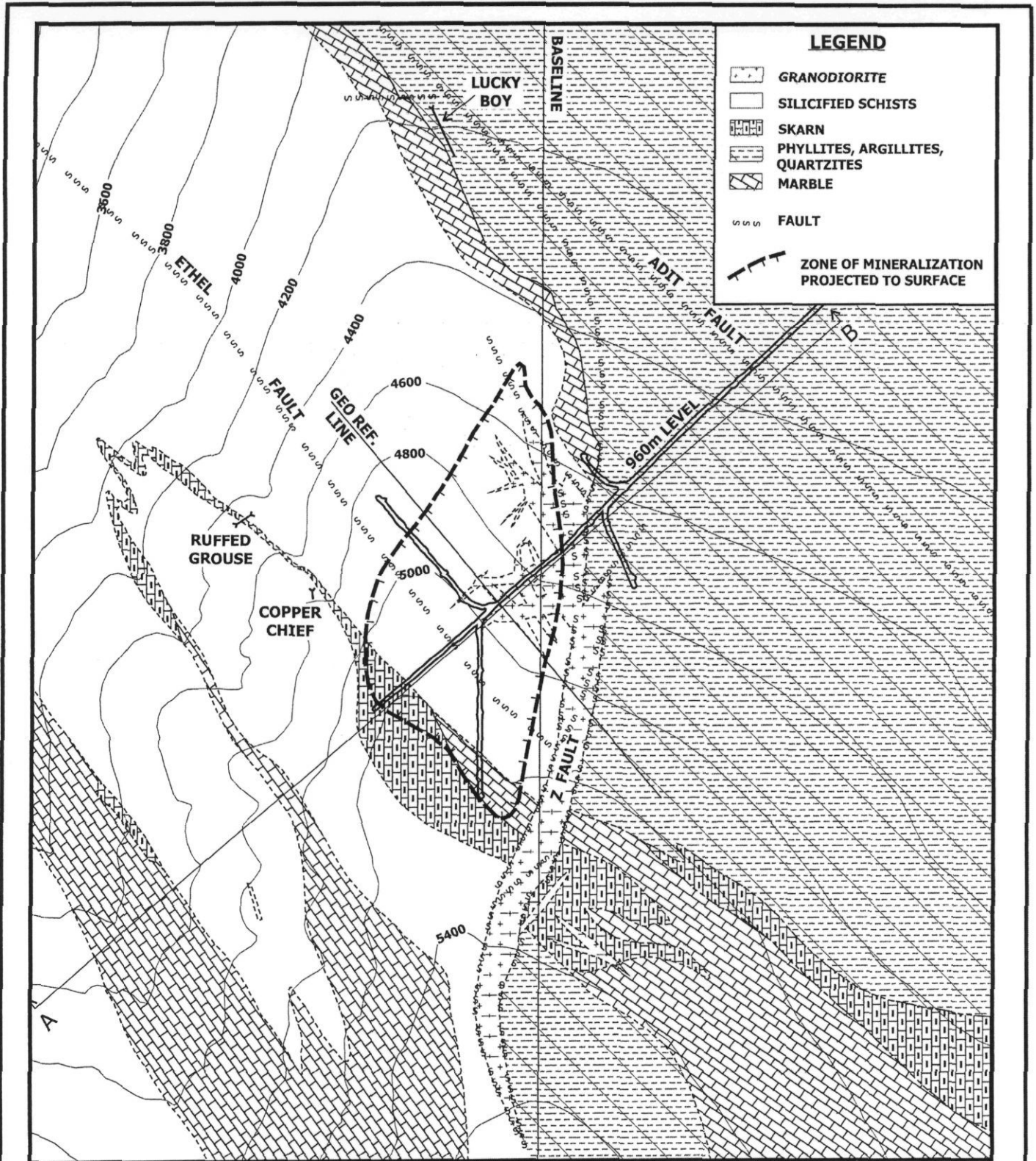

SCALE 1:5,000

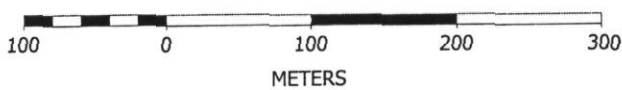

AFTER BOYLE, LEITCH (1983)

PROJECT				MAX MOLYBDENUM PROJECT	
TITLE				SURFACE GEOLOGY MAP	
DATE	SCALE	DRAWN			
AUGUST 2004	1:5,000	WKL			
PROJECT No.	FIGURE No.	REV.			
0327-003-01	4	0			



Roca Mines Inc.

DEPOSIT TYPES

The MAX molybdenite deposit belongs to the general type of porphyry copper and/or molybdenum deposits, where mineralization is related to a granitic or granodioritic intrusive that may be either a distinct stock or a phase of a larger batholith. In this type, mineralization is broadly dispersed in the form of disseminations or fracture filling veinlets, with sulphide mineral content seldom exceeding several percent. Ground preparation in the form of fracturing, faulting and brecciation to allow access by mineralizing fluids is important. The mineralization of interest may be confined to the intrusive body or largely present in the country rock adjacent to the intrusive. Dyking of the country rock by contemporaneous or later phases of the intrusive may be common. Mineralized quartz veins are common in molybdenum deposits, and where prevalent enough in a criss-crossing network the deposit is termed a stockwork. Linnen (1995) and Westra & Keith (1981) discuss the characteristics of this type.

MINERALIZATION

Molybdenite mineralization has been intersected in drilling from surface to a depth of 1000 m at the MAX property. As shown on Figure 6, the 0.10% MoS₂ contour defines the deposit and reveals the following form; the smaller upper A Zone occurs along the west side of the Z Fault for a length of 250 m, tapering inward in width to a depth of 300 m at the 1100 m elevation. Separated from the A Zone by about 70 m of weak mineralization, B Zone extends from 1200 m down to 600 m elevation with a lateral extent of 200 m by 300 m at the adit level (960 m elevation). Adjoining B Zone at the southeast side, C Zone comprises the mineralization lying on the east side of the Z Fault. Below the adit level, the B Zone assumes a steep southwesterly plunge and links with the D Zone. The D Zone has been traced by drilling for a length of 270 m and extends from 840 m down to 500 m elevation. Further southwest beyond the D Zone, two holes have intersected the F Zone. Mineralization is not delimited at depth, and the few holes reaching the 500 m elevation have shown widespread weak mineralization with occasional better grade intercepts.

Molybdenite is the only mineral of economic importance in the MAX deposit. Some of its yellow oxidation product is seen in surface trenches, but does not persist downward to the drill intercepts. Minor pyrite and pyrrhotite accompany the molybdenite, with pyrite predominating on the margins of the deposit and pyrrhotite more abundant in the centre. Total sulphide content averages about 1 to 2% and runs as high as 10 to 15% in the higher grade zones. Very minor chalcopyrite and rare traces of sphalerite, galena and scheelite have been noted in the mineralized zones, but have received exploration attention in the past where they occur in veins or skarns outside the molybdenite deposit.

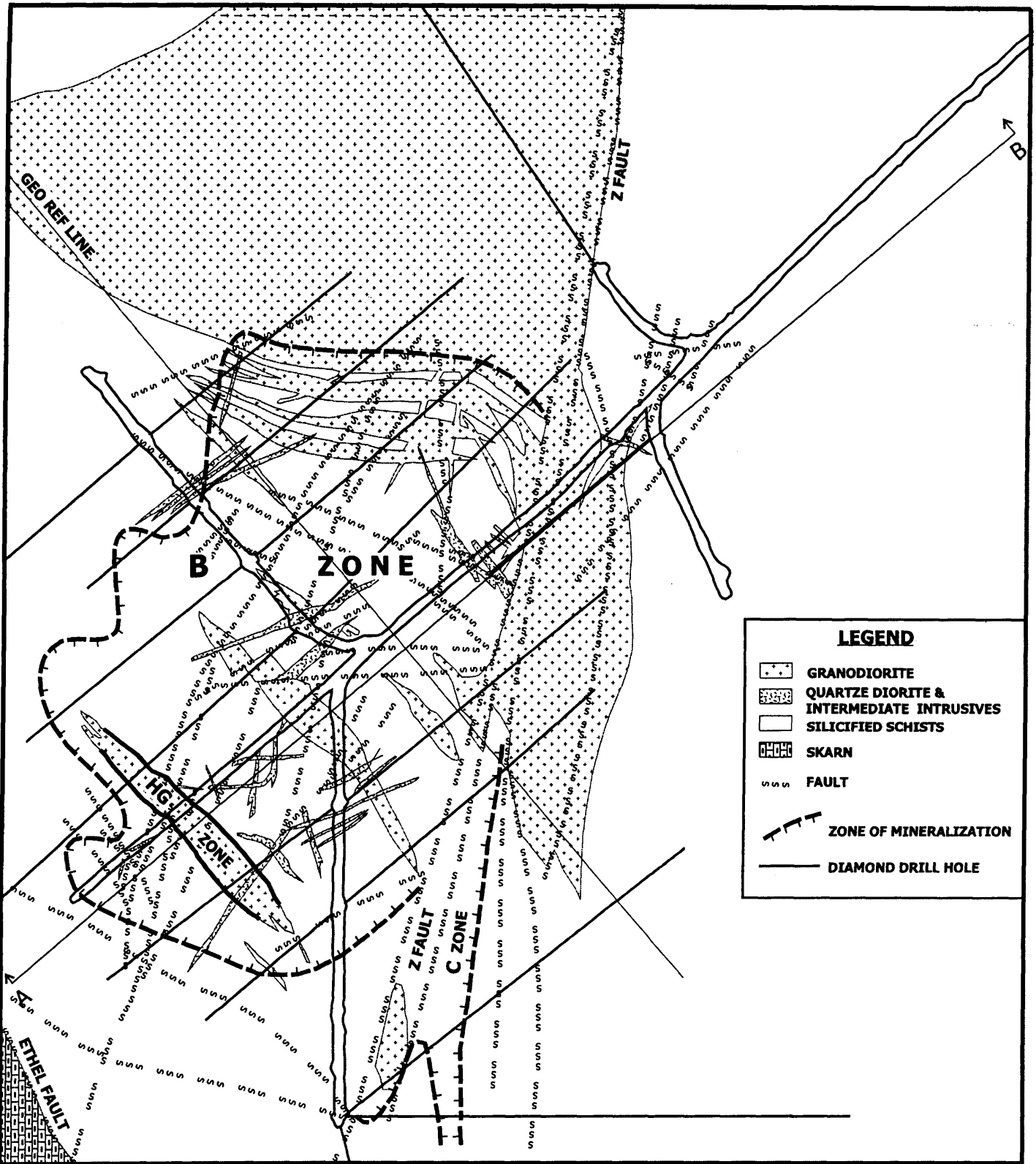

LEGEND

- GRANODIORITE
- QUARTZE DIORITE & INTERMEDIATE INTRUSIVES
- SILICIFIED SCHISTS
- SKARN
- FAULT
- ZONE OF MINERALIZATION
- DIAMOND DRILL HOLE

SCALE 1:2,000

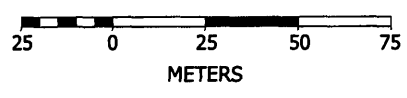

AFTER BOYLE, LEITCH (1983)

PROJECT				MAX MOLYBDENUM PROJECT			
TITLE				960 m LEVEL PLAN			
DATE		SCALE		DRAWN			
AUGUST 2004		1:2,000		WKL			
PROJECT No.			FIGURE No.		REV.		
0327-003-01			5		0		



Roca Mines Inc.

0327-003-01 MAX 960 Level.cdr

Molybdenite, as fine to medium flakes and rosettes accompanied by pyrite/pyrrhotite, is mainly present along the margins of veins in a quartz stockwork. In the higher grade zones (>1% MoS₂) it is strongly disseminated in microfractured intrusive bodies accompanied by large (>10 cm) quartz veins and intense quartz flooding. The vein stockwork is best developed in and around the margins of the intrusive and its dyke-like apophyses. Thus the major mineralization control is the location of the schist-intrusive contact; a lesser control is exerted by pre-mineral faults. The centre of the large granodiorite mass is virtually devoid of veining and mineralization. Post mineral faults have been observed in core to cut off good grade mineralization, but in underground exposure the displacements are seen to be only minor adjustments between blocks. The inter-relationships of cross-cutting, veining and faulting show a suitably complex style of repeated opening of fractures and regeneration of mineralizing fluids as an intrusive differentiated at depth (Boyle & Leitch, 1983).

With regard to continuity of mineralization, the 0.10% MoS₂ grade contour was used to outline the deposit on plan and sections. As can be appreciated in this type of deposit, material below this grade can occur within that contour and some isolated drill intersections at a higher grade can occur beyond the 0.10 shell. Within the 0.10 outline, grade contours were developed at the 0.20, 0.25 and 0.50% MoS₂ levels. Where drill hole density was sufficient, the better grade material showed reasonably good continuity in most cases. Above the 0.50% cutoff level the extent is less certain, with the important exception of the High Grade Dyke (HG Zone) exposed near the southwest end of the adit. Elsewhere within the deposit, intersections several metres long grading more than 1% MoS₂ generally are of unknown orientation and extent.

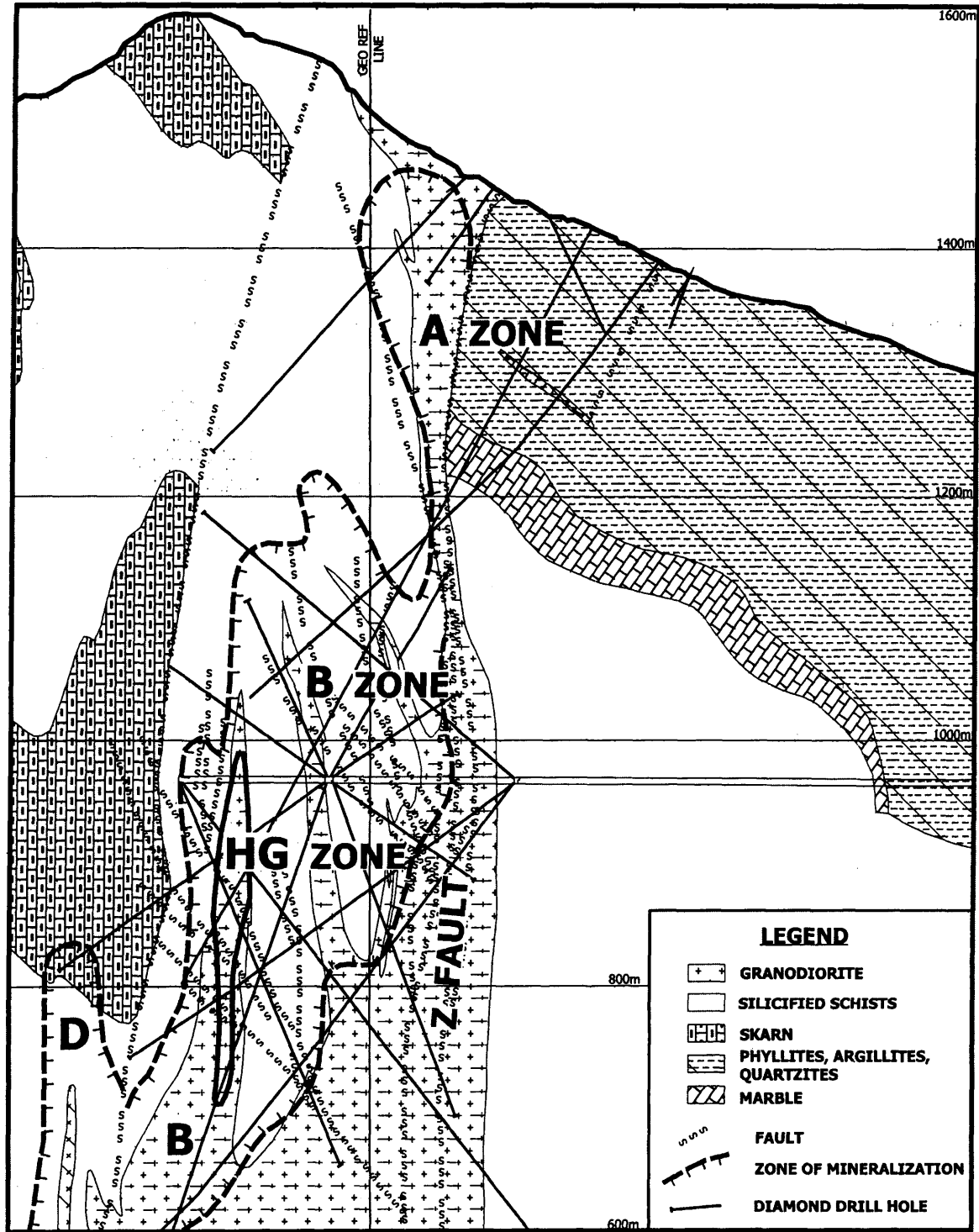

LEGEND

- GRANODIORITE
- SILICIFIED SCHISTS
- SKARN
- PHYLLITES, ARGILLITES, QUARTZITES
- MARBLE
- FAULT
- ZONE OF MINERALIZATION
- DIAMOND DRILL HOLE

SCALE 1:5,000

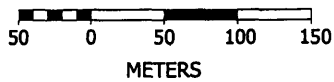

AFTER BOYLE 1982 (NEWMONT)

PROJECT			
MAX MOLYBDENUM PROJECT			
TITLE			
SECTION A - B			
DATE	SCALE	DRAWN	
AUGUST 2004	1:5,000	WKL	
PROJECT No.	FIGURE No.	REV.	
0327-003-01	6	0	



Roca Mines Inc.

EXPLORATION

The only recent exploration work done was a limited surface drilling program by Roca discussed in the next chapter. The following is drawn from the work of the two former operators: Scurry Rainbow Oil (1969) and the Newmont-Esso joint venture (1975-1982).

Geological Work

Basic prospecting was instrumental in finding the small molybdenite occurrences and tracing the train of mineralized float along the slope. Bulldozed drill roads and trenches enlarged the area of mineralization and traced the Z Fault, with its strong quartz veining, upslope to the south.

Mapping done by staff and consultants coincident with drilling developed a better understanding of the Lardeau Group host rocks and complex structure. Alteration, trace element zonation and petrographic studies were carried out by Newmont staff (Hausen 1977, 1981). Linnen's 1995 paper and earlier studies investigated wall rock alteration and hydrothermal evaluation.

Geochemistry and Geophysics

A geochemical anomaly of B-horizon soils, defined by the 100 parts per million (ppm) molybdenum contour, extends 1000 m southeast from the A Zone along the side of the valley as a result of glacial smearing. The 20 ppm molybdenum contour indicates some downslope migration to the northeast and northwest, as well as lesser bedrock sources up the ridge to the south. A more extensive tungsten anomaly (500 x 2000 m at the 120 ppm contour) overlaps with that of molybdenum and probably originates from the scheelite bearing skarns adjacent to the molybdenite deposit.

The magnetometer survey showed only a few scattered anomalies related to pyrrhotite in the skarns; the granodiorite stock could not be outlined magnetically.

Underground Exploration Program

After five seasons of surface work by the Newmont-Esso joint venture, including four seasons of diamond drilling, a significant molybdenite deposit extending to considerable depths had been indicated. The joint venture then decided to undertake an underground program to define the mineralization sufficiently for preliminary mine planning, clarify zones with limited drill information, test new areas too deep to be drilled from surface, and carry out bulk sampling through the heart of the known deposit.

An adit at the 960 m Level elevation was driven in a southwest direction for 1,276 m to the edge of the area of interest. Its size was 12 x 15 feet to allow for future use as a haulage

way and as such is larger than most exploration adits. Beyond that point the adit profile was reduced to 10 x 12 feet, and it continued as a crosscut through the known deposit. Four drifts were driven to provide diamond drill stations; two of them through the deposit were also bulk sampled. Total length of adit and drifts is 2000 m.

Mining conditions contrasted strongly between the approach to the deposit and the drifting within it. Prior to reaching the Z Fault on the east side of the deposit, progress was impeded by numerous water bearing fracture zones. Ground support was required at 13 locations, but outside those zones rock was competent and stood up well. West of the Z Fault in the mineralization and adjacent areas, water inflow was minimal and backs needed no support.

At conclusion of the program, the rail, water and air lines, and ventilation ducting were left installed and their current condition is unknown.

Bulk sampling is described in the chapter "Sampling Method and Approach".

DRILLING

Table 2 – Summary of Diamond Drilling

Year	Operator	Holes	No.	Length (m)
1970	Cascade Moly Mines	TL-1 TO TL-6	6	992
1976	Newmont-Esso	76-1 TO 76-7	7	2,772
1977	Newmont-Esso	77-1 to 77-3	3	1,712
1978	Newmont-Esso	78-1 to 78-5B	7	4,280
1979	Newmont-Esso	79-1 to 79-15	15	6,983
1980-81	Newmont-Esso underground	80-5, 80-6, 81-1 to 81-85	87	22,151
2004	Roca Mines	MM04-01 to 02	2	1,134
Total			127	40,024

The above drilling is in inclined holes, plus flat holes on the adit level, designed to more or less cut across the presumed trend of mineralization. Core size was a mixture of NQ and BQ. Some surface holes were started at HQ, and reduced in stages to penetrate areas of difficult drilling.

Down-the-hole surveys of long surface holes drilled west showed that they deviated to the southwest and flattened somewhat, tending to get perpendicular to the schistosity.

Therefore, the underground drill sections were laid out in the 50° – 230° azimuth orientation to approximate the trend of the surface holes. In the underground program, drill holes over 250 m in length were surveyed with the Atlas Copco Fotobar system that was not susceptible to magnetic attraction; for shorter holes acid dip tests alone were sufficient.

Surface and underground drill holes were plotted on a set of sections with 30 m spacing, numbered one through twelve from northwest to southeast. The segments of the curving holes appearing on each section are those parts of the holes lying within 15 m of either side of the section.

Drill core logging on this project collected more information than simple descriptive and sampling data. Quantitative estimates were made for alteration types (chlorite, sericite, silica (quartz veining), biotite), fracture intensity and total sulphide amount. A graphic log showed lithology and structure. Drill hole survey and assay data were computerized, but inputting the geologic and alteration information turned out to be a terribly time consuming task that was far from complete when the project was suspended. Thus the drill logs, and the plans and sections derived from them, are the basic record for the geology of this deposit.

Surface hole 77-3 on section 7, started at a 65° dip to southwest and finishing at 35° at its bottom at 660 m, yielded a very significant intercept in the B Zone of 0.408% MoS₂ over 271 m. Following this up, 78-5 about 42 m to the southeast on sections 8 and 9, obtained 0.329% MoS₂ over 305 m. To try to assess the lateral extent of this good grade material without the uncertainties of starting new holes from surface, holes were wedged to the right (78-5A) and left (78-5B) from 78-5, achieving separations up to 15 m in 78-5A and 21 m in 78-5B. Two more excellent intersections resulted: 0.443% MoS₂ over 349 m, and 0.225% MoS₂ over 276 m. Within these four long intersections were a number of 10 to 30 m lengths of better grade material in the 0.5 to 1.0% range, plus a few high grade ones, the best of which was 23 m of 3.077% in 78-5A. The latter contained the highest individual sample of 1.5 m containing 7.19%. Underground drilling on the B Zone later confirmed that the best grade material was largely on sections 7 and 8, that the size and grade lessened in a northwest direction on sections 5 and 4, and in a southeast direction on sections 9 through 12. Furthermore, as the B Zone assumed a steep southwest plunge below the adit level ultimately appearing to merge into the D Zone, the long, southwest trending, inclined holes from surface and underground were intersecting it at oblique angles.

Due Diligence Surface Drilling by Roca Mines Inc.

Roca has drilled two NQ holes from surface in the vicinity of previous holes as a due diligence exercise. They have been located by Global Positioning System to UTM coordinates, but have not been tied to the property survey system. It is unknown whether the old survey control in this area can be found. The holes were drilled on the same section 65 m apart. Hole MM04-01 ended when it apparently broke into the adit. Both holes

encountered silicified sericitic and biotitic phyllite cut by 5 granodiorite dykes west of the Z Fault. Molybdenite occurs as concentrations and disseminations in quartz-feldspar veins and veinlets, as fracture fillings in granodiorite and phyllite, and less so as fine disseminations proximal to 5-30 m lengths of granodiorite.

A total 712 core samples, mostly 1.5 m long, from these two holes have been marked for sampling and will be accompanied by blanks and standards. A total of 32 samples have been analysed to date for 23 elements by ICP-MS at ACME Labs using an aqua regia digestion on a one gram sub-sample. Gold analysed on 15 gram sub-samples ranged from 0.5 to 33 ppb. Molybdenum was the only element of economic importance. Results are as follows:

Table 3 – Analyses of Roca Drill Core

Hole No.	UTM Co-ordinates	Azimuth	Dip	Length
MM04-01	457468E 5609721N	215°	-70°	488.7 m
MM04-02	457505E 5609775N	210°	-60°	645.7 m

Hole MM04-02 Intercepts

From	To	Length (m)	No. of Samples	% Mo	% MoS ₂
141.5	143.4	1.9	1	0.036	0.060
143.4	155.5	12.1	8	0.390	0.650
160.0	161.5	1.5	1	0.706	1.177
164.5	166.0	1.5	1	0.186	0.310
170.5	172.0	1.5	1	0.358	0.597
397.0	424.5	27.5	18	0.345	0.575

SAMPLING METHOD AND APPROACH

Diamond Drilling

A total of 14,889 diamond drill core samples in the Newmont-Esso program were taken for assay, comprising 4,951 from surface drill holes and 9,938 from underground holes. Sample lengths were generally 2m in mineralization and 3m in very weak mineralization, with the standard length being modified where abrupt changes in grade or geologic boundaries were evident.

Virtually all core from within the broadest outline of the mineralized zone was sampled. Prior to sampling, core from the underground program was photographed. Core splitting of surface drill holes was done by chisel splitter; for the underground holes by diamond saw. Underground core size was a combination of NQ and BQ. Where BQ holes alternated with NQ ones in the ring drilling, it was deemed unnecessary to keep split core and the BQ core (comprising 24% of the 21,657m sampled) was sampled whole.

Core recovery in the mineralized area was good, averaging 93% in the underground program. Drill core was retained on the property; some of it was lost in the collapse of the core shed after the project became inactive and the remainder was destroyed in the 2003 reclamation program.

Bulk Sampling

A bulk sampling program was also carried out during the Newmont-Esso program a comparison to the drilling results, and also provide material for metallurgical testing. Individual rounds from the adit, comprising about 90 tonnes, were segregated into concrete bins, then stored in a prepared stockpile area with assigned lot numbers identifying the round's location on the underground plan. A total of 189 bulk samples were stored. A total of 227 samples were processed through the crushing plant and sampling tower, comprising one from each round, plus 38 check samples from 24 of those rounds. See Figure 7 for the processing flowsheet. No stockpiled or drummed mineralized material remains after it was collected and buried in the reclamation program.

Of the 189 rounds excavated, 128 had a pilot diamond drill hole through them. Compared round by round, the bulk sample grades varied from 85 to 137% of the DDH grades calculated for the same 3m intervals as the drift rounds. It is noteworthy that the sample size ratio for these two types is 12,000 to 1. The arithmetic average grade for the bulk samples was 0.222% MoS₂ versus 0.205% for the DDH's, or 8.3% higher. In a lognormal analysis the difference is 1.4% higher (0.217 versus 0.214% MoS₂).

BULK SAMPLING DESIGN FLOW SHEET

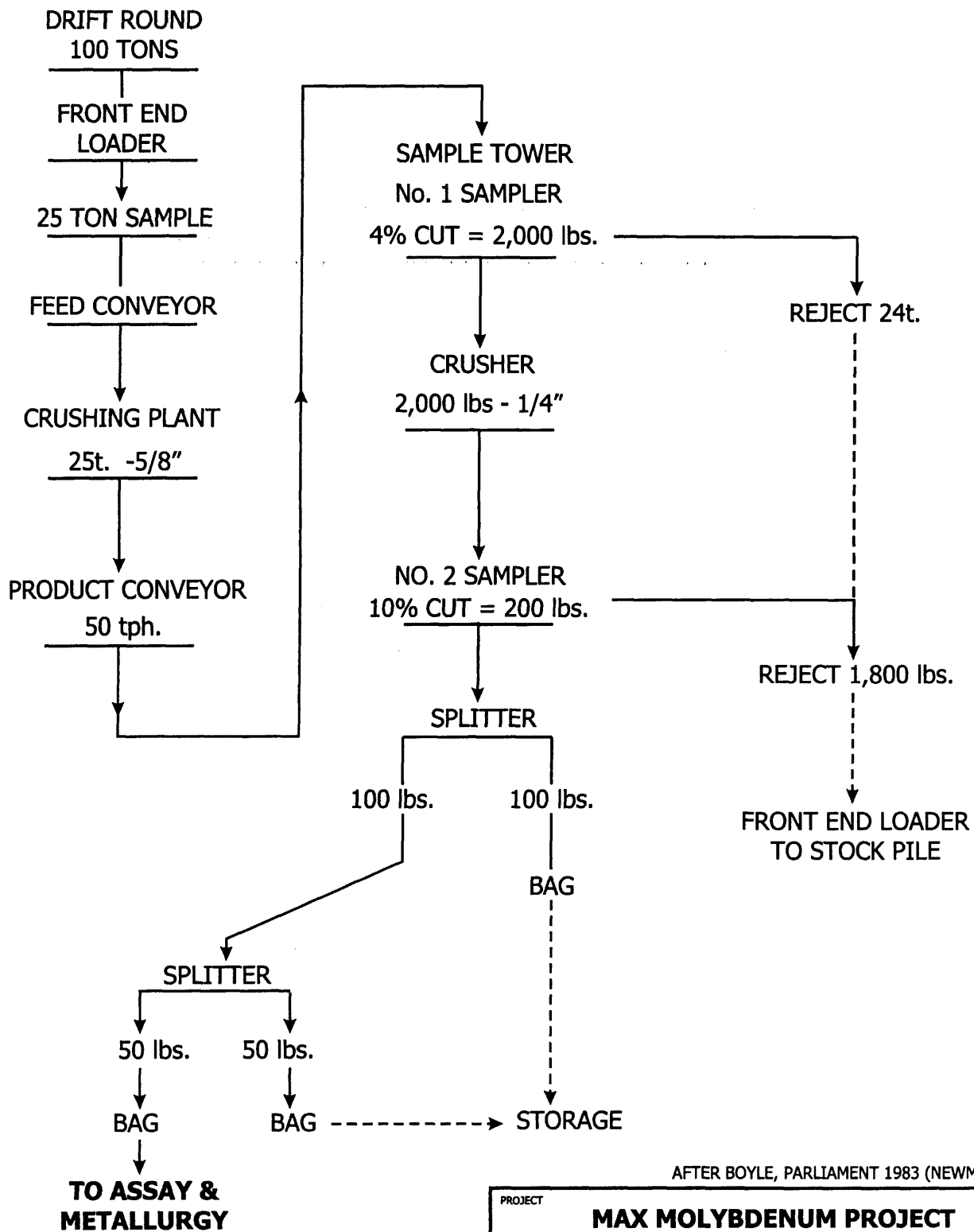

AFTER BOYLE, PARLIAMENT 1983 (NEWMONT)

PROJECT			
MAX MOLYBDENUM PROJECT			
TITLE			
BULK SAMPLE FLOW SHEET			
DATE	SCALE	DRAWN	
AUGUST 2004	-	WKL	
PROJECT No.	FIGURE No.	REV.	
0327-003-01	7	0	



Roca Mines Inc.

0327-003-01 MAX Bulk Sample.cdr

SAMPLE PREPARATION, ANALYSES, SECURITY

Sampling of the diamond drill core from the Newmont-Esso work was done on-site by Newmont employees. Samples were sent by commercial transport to Chemex Labs in North Vancouver for assay. Their procedure was to crush each sample to ¼ inch, then split to about 250 grams (g) for pulverization. Following the 1978 program, a finer crushing to 1/8 inch was specified to produce a more homogenous sample prior to splitting. For the underground (UG) drill hole samples, a three stage crushing procedure was employed. A 2 g sub-sample of pulp was digested in hot perchloric citric acid mixture, diluted to a specified volume, buffered with aluminium chloride, and the quantitative determination made by atomic absorption spectrophotometry against prepared standards.

The bulk samples and pilot diamond drill holes were assayed in the Newmont research lab at Danbury, Connecticut, because that is where the subsequent metallurgical testing was to be carried out. The differences in procedure from Chemex involved using a 1g sub-sample instead of 2g, and digestion with a mixture of nitric, perchoric, hydrochloric and hydrofluoric acids. The above labs utilized industry standard quality control procedures, but certification by standards associations was not in place at that time.

A check assay program was carried out utilizing about 1% of the surface and UG drill samples selected to cover a grade range of 0.05 to 4% MoS₂. To check sample preparation, resplits of the crushed rejects from the 1976-1979 surface drilling showed a rather high 35% of the assays disagreed by more than 20% with the original assay. This caused the decision to go to a finer crush, resulting in a more acceptable 9% of the UG samples deviating by more than 20% from the original. Re-assays of the original pulps showed 6% of the surface drilling samples and 0% of the UG samples deviating by more than 20% from the original. A small proportion of these samples were also run at two other commercial labs. All sample pulps from the Newmont-Esso work have been discarded.

The check program did not involve introduction of blanks and standards into the sample stream, but was considered sufficient to identify any sampling/assaying problems. As for security, Newmont supervisory staff lived on-site during the work periods and were regularly involved in training and checking on employees and contractors.

DATA VERIFICATION

During the seven year period that the Newmont-Esso data was being generated and compiled, the author frequently reviewed results and met with project geologist Craig Boyle, P.Eng., who carried out or supervised the core logging, assay entry and assay averaging. Property visits included core examination with comparison to assay results. Spot checks by the author and others were made on assay entry, processing and interpretation, with thorough discussion and resolution of any differences that were identified. It is the opinion of

the author that the work from this period, comprising the vast majority of total work on the molybdenite deposit, has produced a reliable set of data that can be utilized in advancement of this project.

Regarding the recent diamond drilling by Roca carried out for due diligence purposes shortly after acquiring the property option, the author has examined the assay certificate and cross-section, but concludes that it is premature to include this information into the data set because of incomplete sampling and the imprecise location of the holes with respect to the earlier drilling in that area.

MINERAL PROCESSING & METALLURGICAL TESTING

Test work carried out at the Newmont facility in Danbury, Connecticut, was done on five composites of drill core from 1978 – 79 holes and a more extensive bench-scale investigation of bulk samples from the adit and its horizontal pilot holes.

Testing of the five core composites (Table 4) indicated that a simple flowsheet incorporating primary grinding to –65 mesh, rougher and scavenger flotation of molybdenite with frother only, regrinding of the rougher concentrate and multiple cleaning stages would recover above 90% of the molybdenite in a concentrate assaying 90-92% MoS₂. The final concentrate contained up to 0.5% Cu, which could be detrimental in selling this product. A small addition of sodium cyanide, not more than 0.01 lbs per ton of original feed added to the cleaner stage, reduced the copper content to less than 0.05%, a threshold limit generally applied to molybdenum oxide product.

Table 4 – Summary of Metallurgical Results 1979 – 1980

Composite No.	Zone	Hole No.	Interval	Sodium Cyanide	Assay Head & MoS ₂	Final Concentrate			MoS ₂
						% MoS ₂	% Cu	% Fe	% Recovery
1	B	78-5	61 ft from 1,075 ft to 1,150ft	No	0.366	96.91	0.028	0.22	86.9
2	B	78-5A	97 ft from 1,750 ft to 1,860 ft	No	0.274	93.55	0.33	1.02	91.0
				Yes	0.274	94.87	0.01	1.04	90.6
3	B	79-1	103 ft from 1,477 ft to 1,580 ft	No	0.150	92.15	0.30	0.79	81.8
				Yes	0.150	92.14	0.01	0.49	82.4
4	A	79-1	142 ft from 498 ft to 640 ft	No	0.286	89.3	0.46	0.87	91.6
				Yes	0.286	91.9	0.02	0.48	89.9
5	A	79-4	140 ft from 230 ft to 370 ft	No	0.178	91.3	0.23	0.70	90.3

Table 5 – Summary of Results – Adit Samples – 960 Level

Sample Description	Assay Head % MoS ₂	Final Concentrate			MoS ₂
		% MoS ₂	% Cu	% Fe	% Recovery
Master composite of drill core (80-5)	0.37	85.46	0.46	3.76	90.8
Master composite of drill core (80-5)	0.37	90.89	0.44	2.22	83.3
Master composite of drill core (80-5)	0.37	91.62	0.35	2.2	64.9
Granodiorite quartz diorite (bulk sampling)	0.175	93.90	0.45	1.7	89.7
Quartz veining/stockwork + granodiorite quartz diorite (bulk sampling)	0.438	91.35	0.69	2.0	94.0
Silicified schist (bulk sampling)	0.19	81.49	0.59	3.8	92.2
Silicified schist (bulk sampling)	0.19	85.29	0.59	3.2	90.2
Silicified schist (bulk sampling)	0.19	87.68	0.54	3.2	84.0
Silicified schist (bulk sampling)	0.19	91.91	0.45	1.5	67.3
Silicified schist + granodiorite quartz diorite (bulk sampling)	0.45	85.89	0.39	2.8	88.8
Silicified schist + granodiorite quartz diorite (bulk sampling)	0.45	89.35	0.41	2.8	80.5
Master composite* (bulk sampling)	0.23	79.16	0.59	4.7	89.0
Master composite* (bulk sampling)	0.23	83.92	0.52	2.85	88.3

* Master composite = % Wt

- 74.3 Silicified Schist
- 13.9 Granodiorite Quartz Diorite
- 10.4 Silicified Schist + Granodiorite Quartz Diorite
- 1.4 Quartz Veining/Stockwork

Testing of the adit pilot hole 80 – 5 (Table 5) revealed a wide range of MoS₂ recoveries from 90.8 to 64.9%. Testing of individual rock type composites of the adit bulk samples identified silicified schist as the major cause of the problem. Microscopic examination of concentrates identified the major diluent as non-opaque gangue with fine coatings of molybdenite. Appreciable amounts of such material were detected in the silicified schist, but little in the other rock types. While such middling can be produced in grinding, the investigator stated that the major portion in the silicified schist is of geologic origin. The Master Composite, made up on a weighted basis of silicified schist, granodiorite, quartz diorite, and quartz vein/stockwork ore grade intersections, gave similar results as obtained from the Silicified Schist alone. Further investigation was planned using underground drill core, but testing was halted when the project was shelved.

When Roca wishes to follow this up, one or several large samples could be taken from the adit walls of mineralised silicified schist. The east wall of No. 4 Drift South at Section 8 drill station would be on appropriate locality. Alternatively, the crushed rejects of this rock type from the definition drilling could be used.

MINERAL RESOURCE ESTIMATE

In 1982 after all drilling results were in and data compiled, a resource estimate was made by Newmont staff members Craig Boyle, P.Eng., geological engineer, and Trevor Hancock, P.Eng., mining engineer, under the overall direction of the author. The results are documented in Boyle and Parliament (1983). In 2004, the author was retained to review this estimate, modify it where appropriate, and make further estimates at higher cutoff grades if possible. Table 6 presents the detailed compilation of the mineral resource by zone, category and four cutoff grades. Table 7 states the total resource after rounding and combining according to the CIM Standards, in the form suitable for public disclosure.

As required by NI 43-101, it is stated that the economic viability of mineral resources are not demonstrated. This cannot be determined until a prefeasibility or feasibility study has been done.

Estimation Method

The resource estimate is based on drill holes plotted on sections 3 to 13, with 30 m spacing between sections. Grade contours were developed based on drill hole assays, continuity from hole to hole and conformity to the geological interpretation. They were drawn at 0.10, 0.20, 0.25, 0.50 and 1.00% MoS₂ level. Then the outlined zones were divided into polygons, for the most part based on individual hole intercepts falling between two grade contours. In areas around drill stations where hole density is high, a weighted average grade for the polygon was calculated. Other exceptions are cases where the polygon is defined by a drill

hole(s) on an adjacent section(s) on either or both sides. Extensions of geologic trends are also used to define the polygons. An example is shown on Figure 8.

Volumes for each polygon were generated by planimetering each polygon to measure the area in square metres, and then multiplying that by 30 metres (15 m to each side) to obtain the volume in cubic metres. The volume was then multiplied by the specific gravity to obtain the tonnage in metric tonnes. The specific gravity used was 2.72, determined from the average of three representative samples of drill core. Confirmation of this value was obtained from bulk sampling composites.

A standard 15 m projection on either side of the section plane was used instead of trying to adjust the projection length to account for details of the contoured zones. As a check, tonnages were also calculated based on level plans at 50 m intervals. For the largest and most thoroughly drilled B Zone, the tonnage calculated from the two methods to the 0.10 contour agreed to within 3%, but the poorly understood F Zone with only two drill holes had a discrepancy of 53%. Likewise, the small zones of plus 0.25% MoS₂ gave wider variations, pointing to the uncertainty with which they are defined.

The 0.10% MoS₂ cutoff was originally selected as appropriate for a large tonnage deposit with potential for lower cost bulk mining methods. It was also close to that used at other well-known deposits and operating mines. It was recognised, as it is today, that this deposit lends itself to the study of applying higher cutoff grades producing higher grade/lower tonnage resource estimates. These can then be utilized in analyzing a variety of operating scenarios.

No allowances for dilution or mining losses have been incorporated into these estimates. No trench or adit bulk samples were used, with the exception in this new study of combining bulk sample and pilot drill hole grades for two polygons on Section 8 for the plus 0.50% calculation.

The 1982 estimate showed 0.50 and 1.00% grade contours on Sections 7 and 8, but did not present tonnages at those cutoffs in its compilation table. The present study has segregated additional plus 0.50% material in B Zone on Sections 6 to 9. The most significant is the HG Zone (within the B) on Sections 7, 8 and 9 where 13 polygons contain 706,000 tonnes averaging 1.067% MoS₂ in a vertical body 60 to 90 m long, 235 to 335 m high and 7 to 28 m wide. At the 1.00% cutoff, seven polygons containing 280,000 tonnes averaging 1.946% are present in various places, nearly all in the B. They cannot be considered as mineable on their own without more detailed drilling/drifted/raising in their vicinity. A number of drill intercepts at the plus 0.50 and plus 1.00% grades, up to 5 m long, are of unknown orientation and extent. They have not been segregated from the lower grade material, but offer potential for narrow good-grade mining if detailed exploration can demonstrate continuity.

Table 6 - MAX Property – Mineral Resources By Zone

Zone	Cutoff	MEASURED			INDICATED			INFERRED		
		Tonnes	Grade % MoS ₂	Tonnes x Grade	Tonnes	Grade % MoS ₂	Tonnes x Grade	Tonnes	Grade % MoS ₂	Tonnes x Grade
A	0.10				5,191,150	0.202	1,046,155			
	0.20				1,355,948	0.414	560,697			
	0.50				239,497	0.791	189,486			
	1.00				18,197	1.874	34,101			
B	0.10	26,599,345	0.211	5,609,629	2,866,045	0.172	494,011			
	0.20	9,142,725	0.354	3,235,719	186,293	0.414	77,211			
	0.50	1,007,760	1.007	1,015,057						
	1.00	261,529	1.951	510,255						
C	0.10	1,267,249	0.153	193,904	2,961,999	0.143	422,759			
	0.20	201,305	0.305	61,404						
	0.50									
	1.00									
D	0.10				4,053,332	0.178	722,876	6,466,966	0.162	1,045,965
	0.20				467,813	0.403	188,702	456,144	0.329	150,213
	0.50				131,213	0.726	95,258			
	1.00									
F	0.10							2,437,311	0.150	365,179
Total	0.10	27,866,594	0.208	5,803,533	15,072,526	0.178	2,685,801	8,904,277	0.158	1,411,144
	0.20	9,344,030	0.353	3,297,123	2,010,054	0.411	826,610	456,144	0.329	150,213
	0.50	1,007,760	1.007	1,015,057	370,710	0.768	284,744			
	1.00	261,529	1.951	510,255	18,197	1.874	34,101			

Table 7 – MAX Property – Total Mineral Resources

MEASURED			INDICATED		MEASURED & INDICATED		INFERRED	
Cutoff % MoS ₂	Tonnes	Grade % MoS ₂	Tonnes	Grade % MoS ₂	Tonnes	Grade % MoS ₂	Tonnes	Grade % MoS ₂
0.10	27,870,000	0.21	15,070,000	0.18	42,940,000	0.20	8,900,000	0.16
0.20	9,340,000	0.35	2,010,000	0.41	11,350,000	0.36	460,000	0.33
0.50	1,010,000	1.01	370,000	0.77	1,380,000	0.94		
1.00	260,000	1.95	20,000	1.87	280,000	1.95		

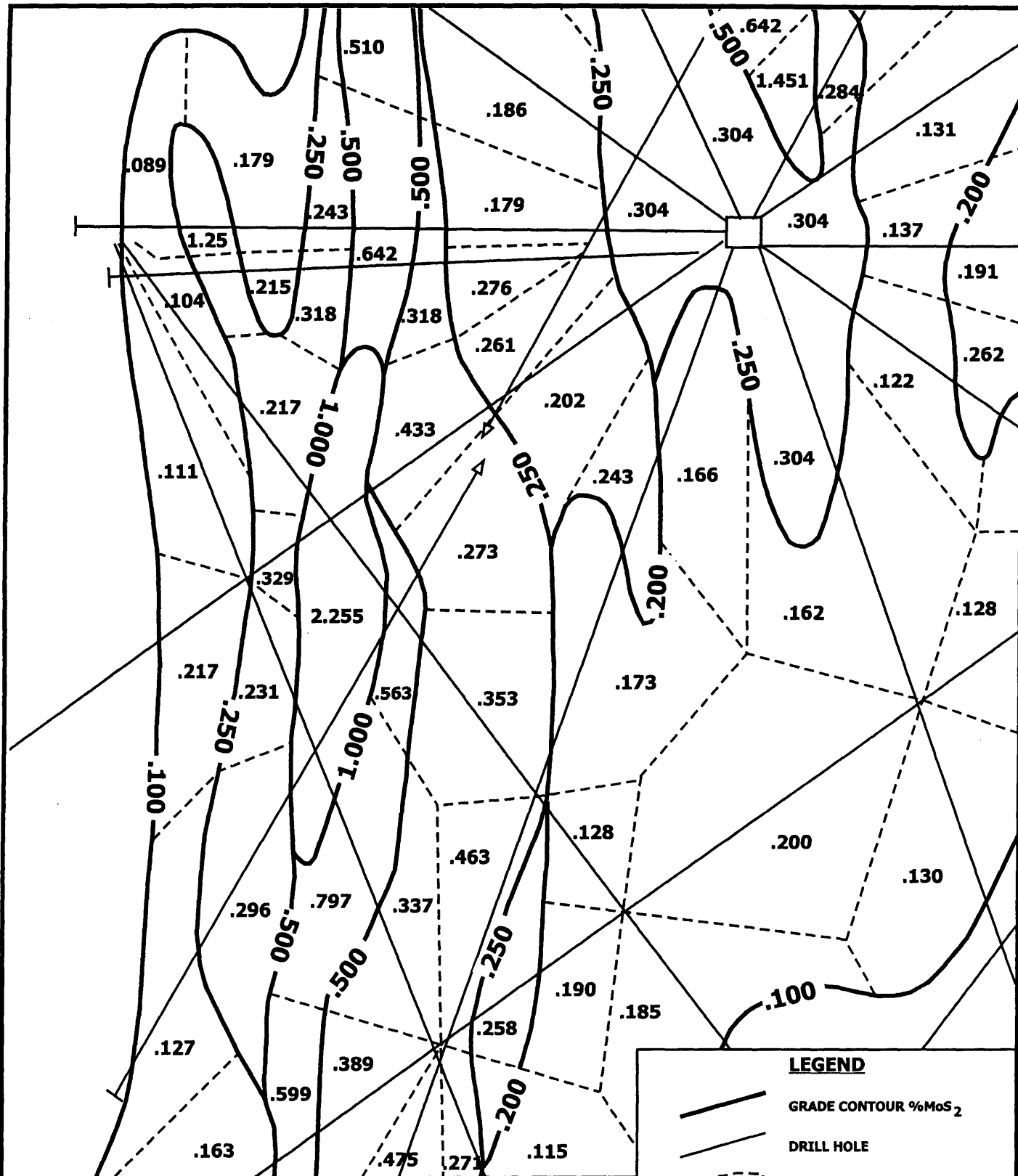

SCALE 1 : 1,000

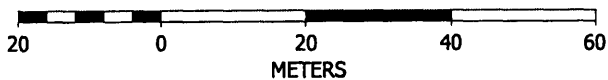

LEGEND

- GRADE CONTOUR %MoS₂
- DRILL HOLE
- POLYGON WITH GRADE

PROJECT			
MAX MOLYBDENUM PROJECT			
TITLE			
RESOURCE POLYGONS - SECTION 8			
DATE	SCALE	DRAWN	
AUGUST 2004	1:1,000	WKL	
PROJECT No.	FIGURE No.	REV.	
0327-003-01	8	0	



Roca Mines Inc.

0327-003-01 MAX Resource Polygons.pdf

The present review has also added new polygons of material in the 0.10 to 0.20% grade range, with 20 to 60 m widths, based on drill intersections not considered in the 1982 estimate. They are mainly in the D Zone, plus two above the B Zone.

Resource Categorization

In the 1982 estimate, a polygon was classified as "drill-defined" if it had a drill hole through it and was supported by similar intercepts in surrounding holes or by well established geologic trends. "Drill-indicated" polygons were those drawn from single drill holes with no firmly established geologic controls for guides, or with no drill holes within them and based solely on the extension of trends derived from the geologic interpretation. In a few instances, where the trends were strong, it was justified to include in the defined category a polygon without a drill hole intercept.

In the present review, the following changes have been made in resource categorization of the 1982 estimate to conform to the definitions in the CIM Standards (2000) required by National Instrument 43-101. For the B and C Zones, the "drill-defined" tonnage (comprising most of these zones) becomes the "measured" category and the small amount of "drill-indicated" becomes "indicated". The grade contours derived from the underground holes (and to a lesser extent surface holes) have been confirmed in the comparison to bulk sample drift-round grades, demonstrating continuity of mineralization between drilled sections. For the A Zone, lacking bulk sampling and close regularly spaced drill holes, the "drill-defined" and "drill-indicated" tonnages have been combined into the "indicated" category. In the D Zone, with less drilling and less precise hole location, the "drill-defined" has been placed in the "indicated" category, and the "drill-indicated" becomes "inferred". The F Zone, with only two drill holes, moves from "drill-indicated" to "inferred".

MINING STUDY

In 1982 following completion of the resource estimate, Newmont engineering staff carried out a preliminary mining study. The mining method considered was open stoping with delayed cemented backfill, using adit and ramp above the existing 960 m Level and shaft and secondary ramp below the Level. Another adit at the 1250 m elevation would be required for development of the higher A Zone and ventilation. Main line haulage on the 960 m Level would be by an electric trolley rail system.

Mining was based on the estimated "geological reserve" of 11,736,000 tonnes of 0.362 % MoS₂ at the 0.20 % cutoff. This was adjusted to include 15% dilution at a grade of 0.14% MoS₂. After fitting the proposed stoping panels to the mineralized outlines and allowing for sill and crown pillars (some of which occur in high grade areas) the estimated recoverable ore was reduced to 8,189,000 tonnes. Two cases were studied: milling rates of 3,000 and 1500 tonnes per day. Following a rough economic analysis, it was concluded that

development of the property was not economically attractive at the then prevailing or prospective price of molybdenum. Further investigation of tonnage – grade combinations at various cutoffs are mentioned in the Boyle & Parliament (1983) report, but the project was shelved before that could be done.

ENVIRONMENTAL CONSIDERATIONS

Between 1979-82 the Trout Lake joint venture retained a number of consulting firms to carry out environmental and socio-economic studies. Beak Consultants concluded that “development of a molybdenum mine...can likely be accomplished without serious detrimental effects to the existing environment of the area. Construction and operation of the mine and concentrator will undoubtedly result in changes, but providing mitigative measures are incorporated during all phases of development, environmental impacts should be kept to a minimum.”

The marshes, wetlands and streams in the valley bottom in the north part of the property, referred to as the Wilkie Creek lowlands, support diverse communities of flora and fauna, including an essential spawning area for sport fish. Beak emphasizes that any development in the area should avoid disturbances to these lowlands. Field surveys gathered valuable information on fish, wildlife and birds. Regular water sampling from October 1978 to May 1982 showed no appreciable difference in heavy metal content in water draining the adit compared to stations upstream and downstream of the confluence of this water with Wilkie Creek. The adit water and streams in the area are slightly alkaline with pH between 7 and 8, and no evidence of acid rock drainage has been found.

Roca has acquired detailed reports of the recent reclamation work done by Rescan Environmental Services for Newmont. They contain extensive analytical information that will be reviewed along with the older data by Roca’s environmental consultants.

With regard to tailings storage, Klohn Leonoff Engineers identified a site immediately downslope from the adit portal and possible plant site. The storage area would be created by constructing dams at each end of the elongated depression between a ridge and the SW valley slope. The underlying material appears suitable for dam foundations, but a strict control of seepage would necessitate an investigation of the permeability of the site.

INTERPRETATION AND CONCLUSIONS

General

Drilling has traced molybdenite mineralization from surface to a depth of 1,000m and over an area of 400 x 500m. Within that block of ground a resource has been defined in several zones over a range of grades. The better grade mineralization is surrounded by medium and lower grade material, offering the flexibility for mine planning and economic analyses to study

a variety of operating scenarios. With the current strong market for molybdenum products, after years of oversupply, it is concluded that this is the ideal time to re-evaluate this project. Producer/dealer prices of molybdenum in oxide form are US \$17.25 - 18.50 per lb of Mo (Northern Miner, August 31/04), after languishing in the US \$2 to 4 range for most of the time since work on this project stopped in 1982.

Roca has acquired an important molybdenum deposit, consolidated the land position, and purchased complete documentation of the exploration/mining/metallurgical/environmental studies, all done at reasonable cost. It is concluded that the project warrants proceeding on two fronts. The near term potential should be assessed by carrying out definition drilling on the High Grade Dyke area of the B Zone, called the HG Zone. At the same time, assessing the potential of the resource at a 0.20% MoS₂ cutoff can start with some drilling to better define it in certain areas, followed by exploration drilling to see if this resource can be expanded.

Exploration Targets

Three areas with potential for adding to the resource were not adequately tested by the drilling that concluded in late 1981. They are situated well within the property boundaries at and below 600 m elevation (adit level is 960 m). They lie to the NW, the SW and E of the known deposit.

The **northwest area** in the D Zone on Sections 4 and 5 has only two holes (81-61 and 81-8) about 100 m apart carrying long sections in the 0.1 to 0.2% MoS₂ range, but within that the deeper hole (81-8) has a 40 m length of 0.40%. The mineralization continues from the metasediments well into a highly altered and veined granodiorite, suggesting a source at depth not yet penetrated by any drill hole.

The **southwest area** is the F Zone on sections 6 and 7 where DDHs 81-15 and 81-63 obtained long intersections averaging 0.2 and 0.1%. More definition is needed, which may result in some better grade material. The occurrence of additional, though small, high grade dykes deeper and to the SW of the High Grade Dyke in the B Zone suggests a continuation in this SW direction. Also the fracturing, veining and alteration in these two holes, particularly in the skarny altered portions, is finer, more closely spaced and more intense than usually seen in the B Zone.

The **east area** exhibits potential on the east side of the Z Fault on sections 7 to 12 and 500 m or more below the adit level. Holes 81-29 and 81-39 on sections 8 to 10 both penetrated granodiorite east of the Z Fault along with well altered silicified schist containing short sections of significant molybdenite. These intersections are sometimes similar in appearance to those above the High Grade Dykes. Considered with the surface drilling, there is a clear increase downwards in the area of alteration and of the extent and grade of

mineralization. DDH 81-84 on sections 8 and 9 never got out of the intrusive, and encountered intense sericitization and pyritization with finely disseminated moly flakes and quartz veins with up to 0.7% MoS₂. The similarity of this hole to surface hole 76-3 suggests the possibility of a 1,000 m down – drop on the east side of the Z Fault, and the possibility of a mineralized zone similar to the B below 81-29, possibly by some 200 m.

RECOMMENDATIONS

1. Complete the sampling and assaying of Roca's two diamond drill holes. When possible, survey their collars to the property coordinate system.
2. Restore road access to the adit portal by replacing culverts removed in the reclamation program, removing drainage barriers, gravel and grading.
3. Restore access to the adit, inspect all underground workings, carry out the necessary rehabilitation and provision of services for diamond drilling.
4. Carry out an underground diamond drill program to better define the medium (> 0.2% MoS₂) and high grade (> 0.5% MoS₂) material in the B Zone. In the High Grade Dyke (HG Zone), bring drill hole spacing to about 20 m on a staggered grid basis for the block between 860 m and 1,000 m elevations.
5. Review the draft environmental impact assessment and supporting studies done for Newmont in 1979-82, and determine what additional work may be necessary to meet current regulations. Determine at what time such additional work should be done.

Cost Estimate

Diamond drilling 3000 m in about 23 holes at \$100/m	\$300,000.00
Underground rehabilitation and equipment	\$194,400.00
Labour	\$24,000.00
Road rehabilitation/maintenance/plowing	\$80,000.00
Fuel and storage	\$120,000.00
Transportation	\$10,000.00
Assays and shipping	\$30,000.00
Room and board	\$45,000.00
Mobilization and demob	\$15,000.00
Environmental, engineering, bond	\$20,000.00
Consulting and management	\$33,000.00
Overhead	<u>\$15,000.00</u>
Sub total	\$886,400.00
Contingency at 10%	\$88,600.00
TOTAL	<u>\$975,000.00</u>

September 20, 2004
Vancouver, BC

"signed" T. N. Macauley, P.Eng.

REFERENCES

- Beak Consultants Limited (1982): Environmental Studies in the Trout Lake Area, for Newmont Mines Limited.
- Beak Consultants Limited (1981): Preliminary Stage I Environmental Assessment, for Newmont Mines Limited.
- Boyle, H.C. and Leitch, C.H.B. (1983): Geology of the Trout Lake Molybdenum Deposit, CIM Bulletin Vol. 76, No. 849, p.115-124.
- Boyle, H.C. and Parliament, J.H. (1983): Trout Lake Project Final Report, private report for Newmont Exploration of Canada and Newmont Mines.
- CIM Standards on Mineral Resources and Reserves *Definition and Guidelines* (2000): Canadian Institute of Mining Metallurgy and Petroleum (www.cim.org)
- Gorken, A. (1980, 1981): Metallurgical Testing of Drill Hole Composites, Newmont Exploration Limited.
- Hausen, D.M. (1976 to 1981): Alteration and Petrographic Studies for Newmont Exploration.
- Hill, R.P. (1980): Geological Mapping Report to Newmont Exploration of Canada.
- Klohn Leonoff Limited (1981): Feasibility Report on a Tailings Storage Facility for Trout Lake Project.
- Klohn Leonoff Limited (1982): Hydrologic and Climatologic Data Collection for Trout Lake Project.
- Linnen, R.L., Williams-Jones, A.E., Leitch, C.H.B., Macauley, T.N. (1995): Molybdenum Mineralization in a Fluorine-poor System: The Trout Lake Stockwork Deposit, in "Porphyry Deposits of the Northwestern Cordillera of North America", CIM Special Volume 46, p. 771-780.
- Macauley, T.N. (1975): Geochemical Report, Trout Lake Property, Newmont Mining Corporation of Canada.
- Makela, K. (1970): Cascade Molybdenum Mines Final Report, Trout Lake Molybdenum Prospect, Scurry Rainbow Oil Limited.

Nabbs, S.W. (1982): Metallurgical Investigation of Samples from the Bulk Sampling Program, Trout Lake Project for Newmont Exploration.

Psutka, J.F., Read, P.B., and Fyles, J.T. (1982): Stratigraphy, Structure and Metamorphism, Trout Lake Deposit and Vicinity, for Geotex Consultants Limited, p.24.

Read, P.B., and Wheeler, J.O. (1976): Geology and Mineral Deposits, Lardeau west half: G.S.C. Open File 288.

Westra, G. and Keith, S.B. (1981): Classification and Genesis of Stockwork Molybdenum Deposits: Econ. Geol., 76, p.844-873.

CERTIFICATE OF AUTHOR

I, Terrance N. Macauley, do hereby certify that:

1. I am a consulting geological engineer with residence and business address at 1057 West 49th Avenue, Vancouver, British Columbia, V6M 2P7.
2. I am a graduate in geological engineering from Queen's University, Kingston, Ontario (B.Sc. 1958), and Michigan Technological University, Houghton, Michigan (M.Sc. 1962).
3. I am a member in good standing of the Association of Professional Engineers and Geoscientists of British Columbia. I am a Fellow of the Geological Association of Canada and a member of the Canadian Institute of Mining Metallurgy and Petroleum.
4. I have practised my profession of mining and exploration geology continuously since graduation.
5. I have read the definition of "qualified person" set out in National Instrument 43-101 (NI 43-101) and certify that by reason of my education, affiliation with a professional association and past relevant work experience, I fulfil the requirements to be a "qualified person" for the purposes of NI 43-101.
6. I am responsible for the preparation of the Technical Report on the MAX Molybdenum Property dated September 20, 2004. I visited the property frequently during its period of exploration from 1975 to 1982, and last visited it on August 20, 1991.
7. I am independent of the issuer applying the tests set out in section 1.5 of NI 43-101.
8. My prior involvement with this property was doing the initial geological mapping and geochemical survey in 1975, and then as exploration manager for Newmont Exploration of Canada, directing the exploration programs in the 1976 to 1982 period.
9. I am not aware of any material fact or material change with respect to the subject matter of this technical report, which is not reflected in the report, the omission to disclose which makes the report misleading.
10. I have read National Instrument 43-101 and Form 43-101 F1, and this report has been prepared in compliance with them.
11. I consent to the filing of the Technical Report with any stock exchange and other regulatory authority and any publication of the Report by them for regulatory purposes,

including electronic publication in the public company files on their websites accessible by the public.

Dated at Vancouver, British Columbia, this 20 day of September 2004.

"signed" T. N. Macauley, P.Eng.