

- LEGEND
- RAISES GOING UP
  - RAISES GOING DOWN
  - RAISES GOING UP AND DOWN

824532

SHEET NO. _____ DATE _____	CLIENT: <b>CANAD SILVER CO. LTD.</b> PROJECT: <b>7500 FT. DEEP</b> DRAWING NO.: _____	TITLE: <b>HOMESTEAD PROPERTY 300 VEN. RESERVE PLAN</b> SCALE: _____ DRAWN BY: _____
-------------------------------	---	---

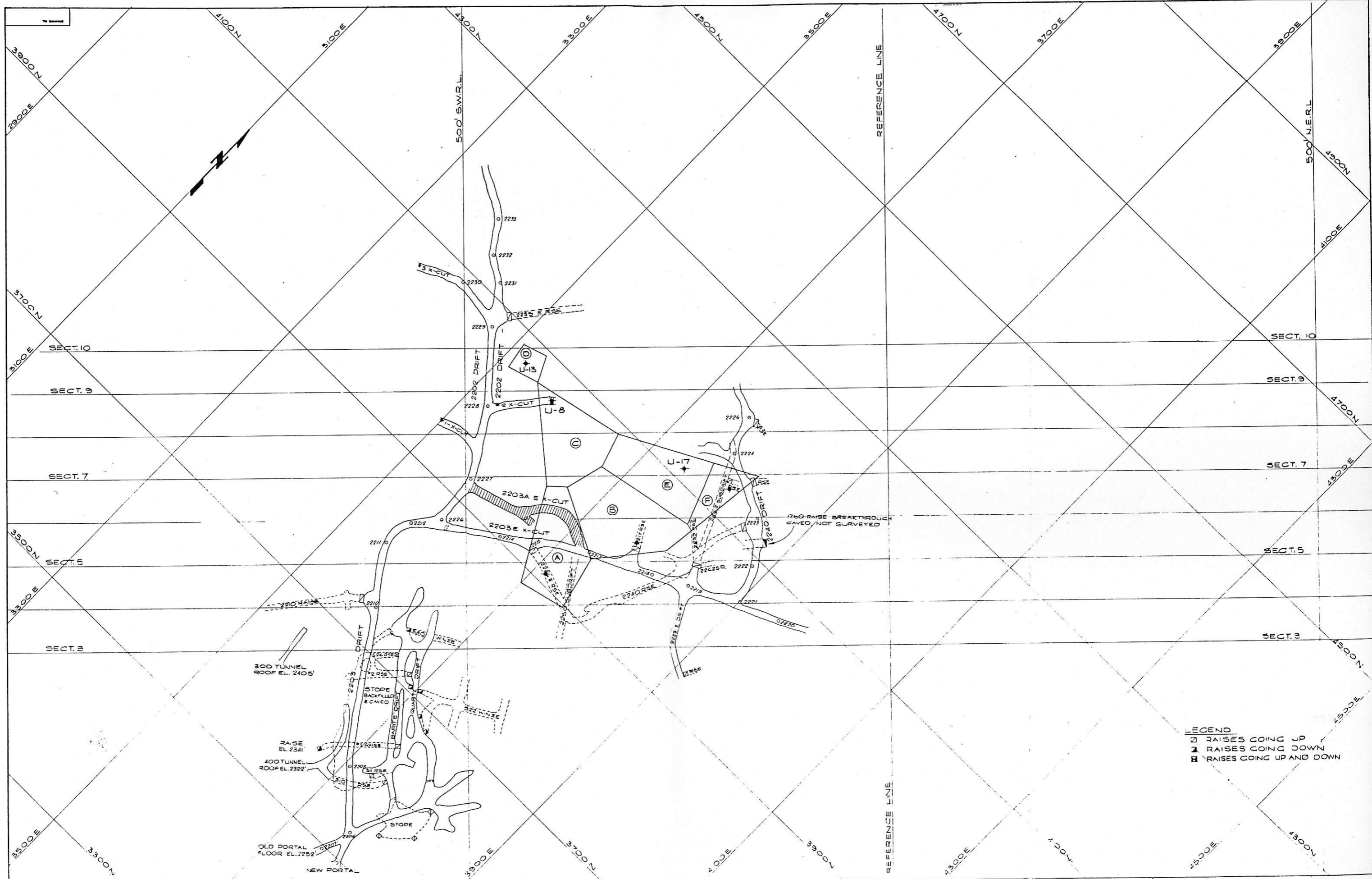

LEGEND  
 □ RAISES GOING UP  
 ▼ RAISES GOING DOWN  
 ▣ RAISES GOING UP AND DOWN

SECTION	DATE	BY	CHECKED	DATE	BY
ARCAD SILVER CO. LTD. BAYVIEW LODGE B.D. 7560 200-05-101			TITLE HOMESTAKE PROPERTY 400 E.V. DRIFT PLAN 7560 200-05-101		

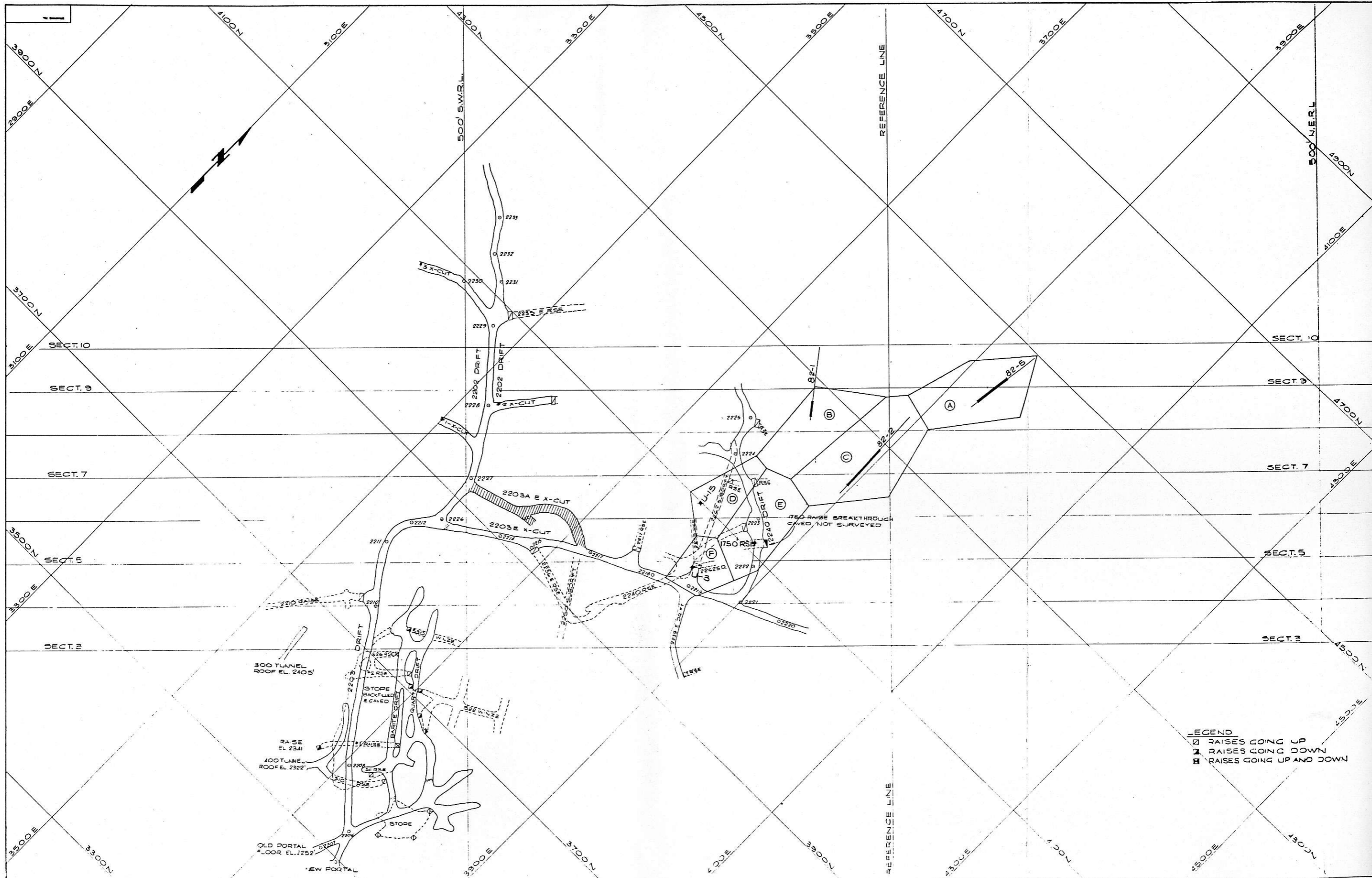

**LEGEND**  
 □ RAISES GOING UP  
 ▽ RAISES GOING DOWN  
 ◻ RAISES GOING UP AND DOWN

SECTION		CLIENT: KAMAD SILVER CO. LTD.		TITLE	
SCALE: 1" = 20'	DATE: DEC 53	PROJECT NO: 7560		SHEET NO: 3	
DESIGNED BY: A.E.S.		LOCATION: KAMLOOPS B.C.		DRAWING NUMBER: 000-05-23	
DRAWN BY: P.A.		DATE: DEC 53		PROJECT: HONESTAKE PROPERTY	
CHECKED BY:		DATE:		RESERVE PLAN	

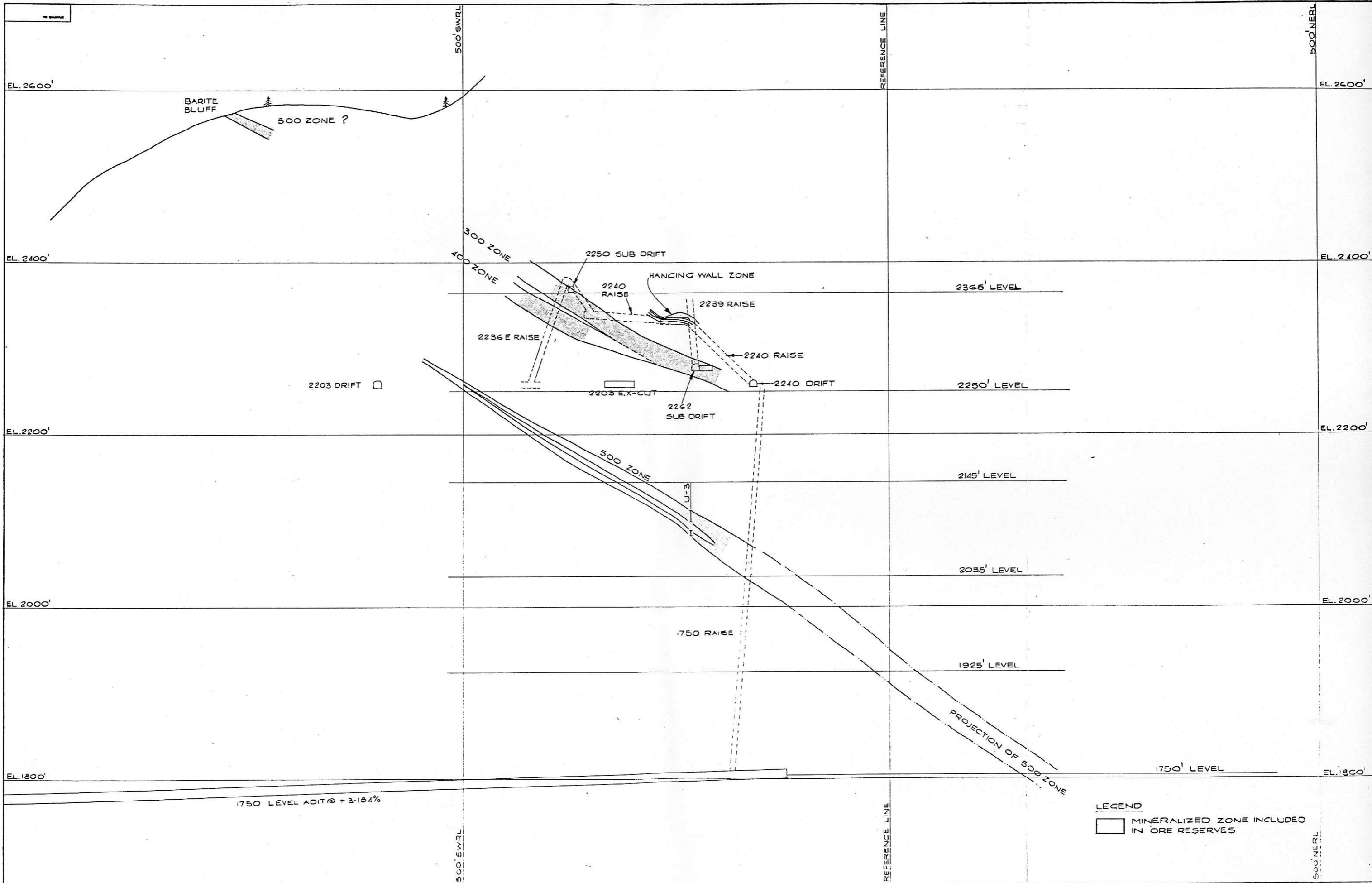

**LEGEND**  
 [Symbol] MINERALIZED ZONE INCLUDED IN ORE RESERVES

SECTION	SCALE 1" = 40'-0"	DATE	CLIENT
DESIGNED BY	A.E.S. DEC. 82	LOCATION	KAMLOOPS B.C.
CHECKED BY	DAVE DEC. 82		
PROJECT NO.		TITLE	
1750		17560	
1750		17560	

**KILBORN**

17560  
 17560  
 CROSS SECTION 175

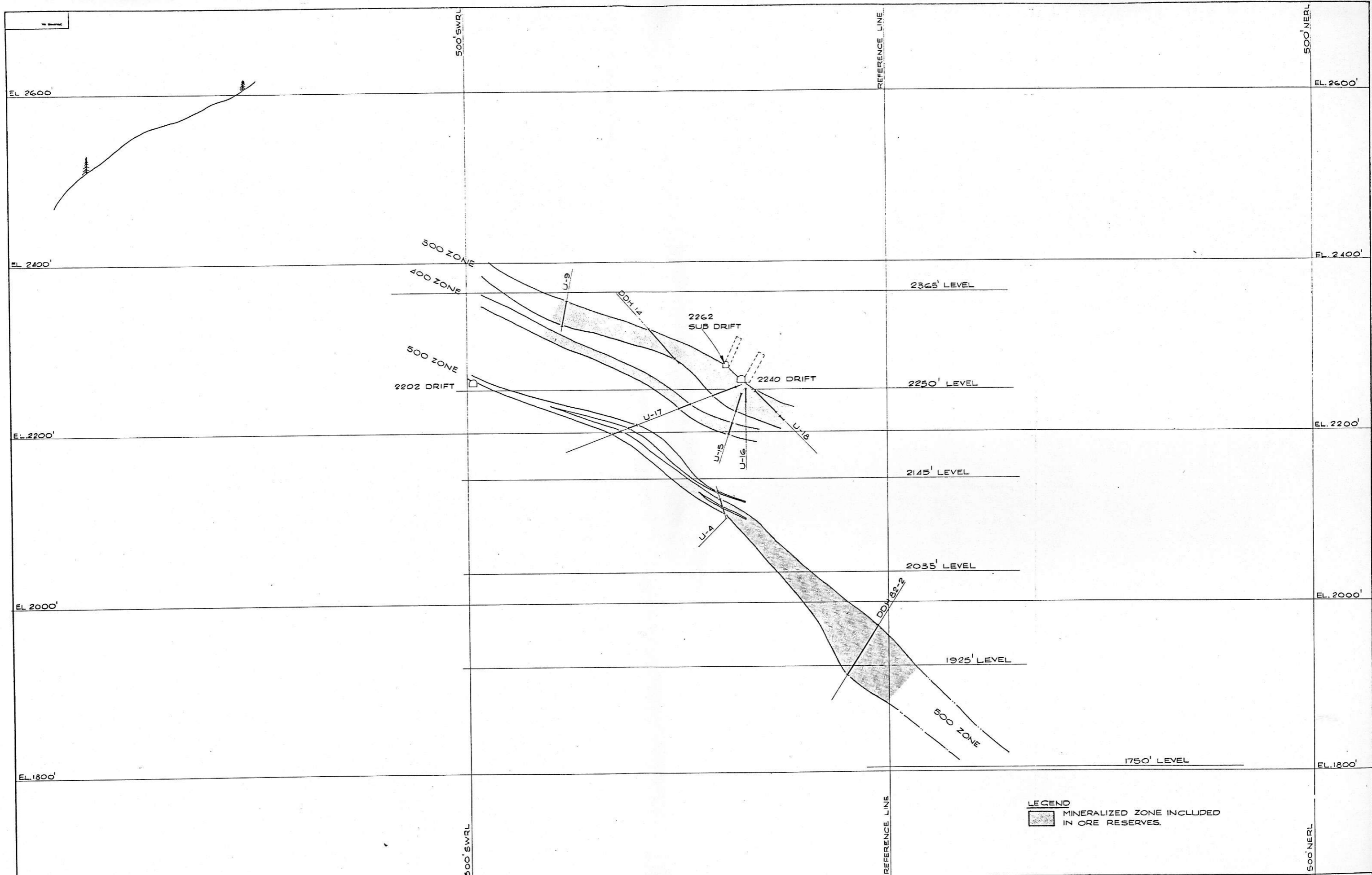

SECTION SCALE 1" = 40'-0" DESIGNED BY AES DEC.82 DRAWN BY RAH DEC.82 CHECKED BY APPROVED BY JBF		CLIENT KAMAD SILVER CO. LTD. LOCATION KAMLOOPS B.C.		TITLE HOMESTAKE PROPERTY CROSS SECTION NO 7		ACT NO. PROJECT NO. 7560 DIVISION NO. 16 DRAWING NUMBER 200-05-F5	
REVISIONS NO. DESCRIPTION DATE BY		REVISIONS NO. DESCRIPTION DATE BY		REVISIONS NO. DESCRIPTION DATE BY		REVISIONS NO. DESCRIPTION DATE BY	

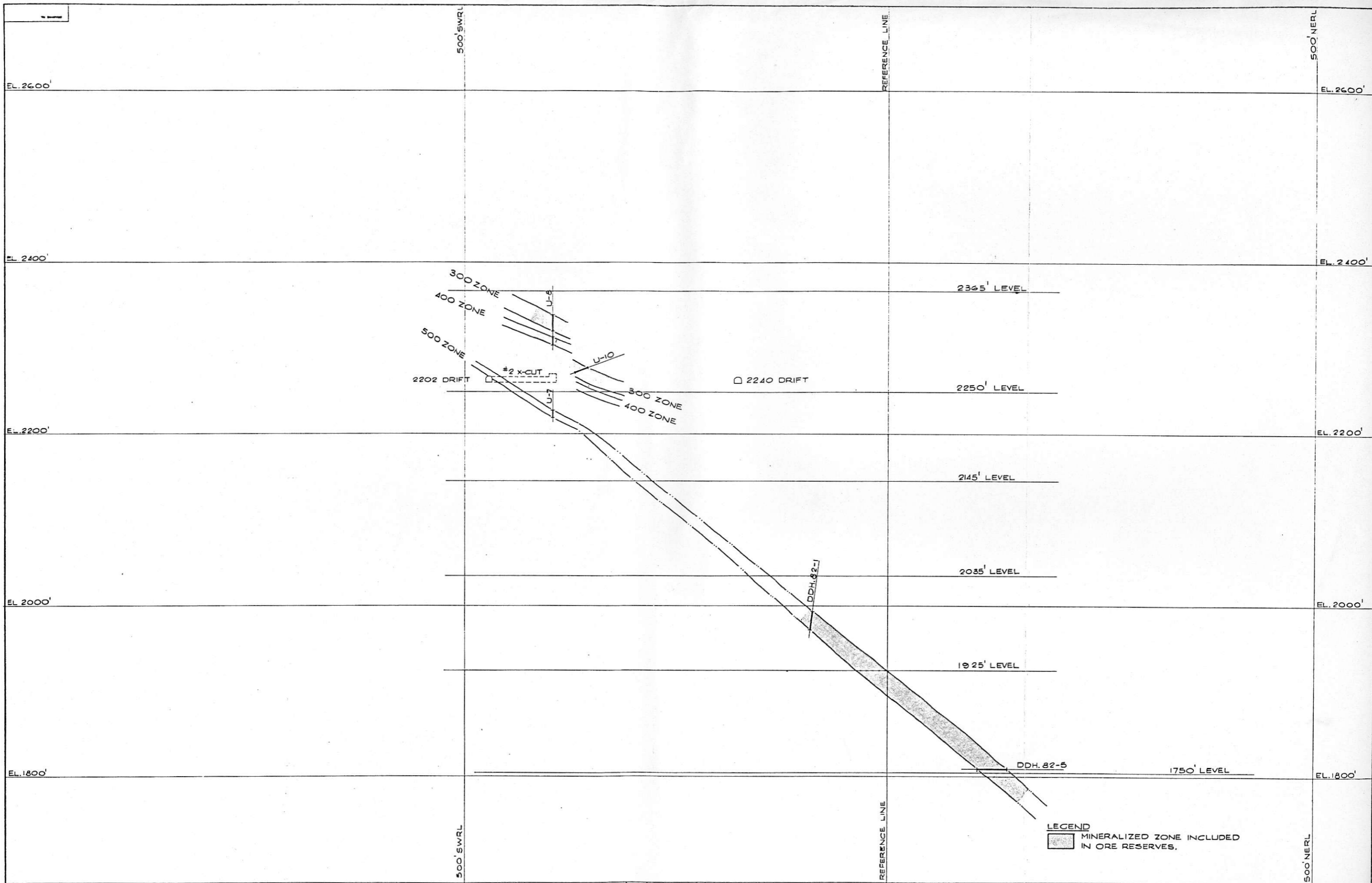

LEGEND  
 [Shaded Box] MINERALIZED ZONE INCLUDED IN ORE RESERVES.

SECTION		KAMAD SILVER CO. LTD.		PROJECT NO.		DRAWING NO.	
SCALE 1" = 40'-0"		DATE		7560		16	
DESIGNED BY A.E.S		DEC.82		DRAWING NUMBER		200-05-F6	
DRAWN BY P.A.H		DEC.82		APPROVED BY		JBF	
CHECKED BY		DATE		TITLE		HOMESTAKE PROPERTY CROSS SECTION N° 9	
APPROVED BY		DATE		KILBORN			
DESCRIPTION		DATE		DESCRIPTION		DATE	
REVISIONS		REVISIONS		REVISIONS		REVISIONS	

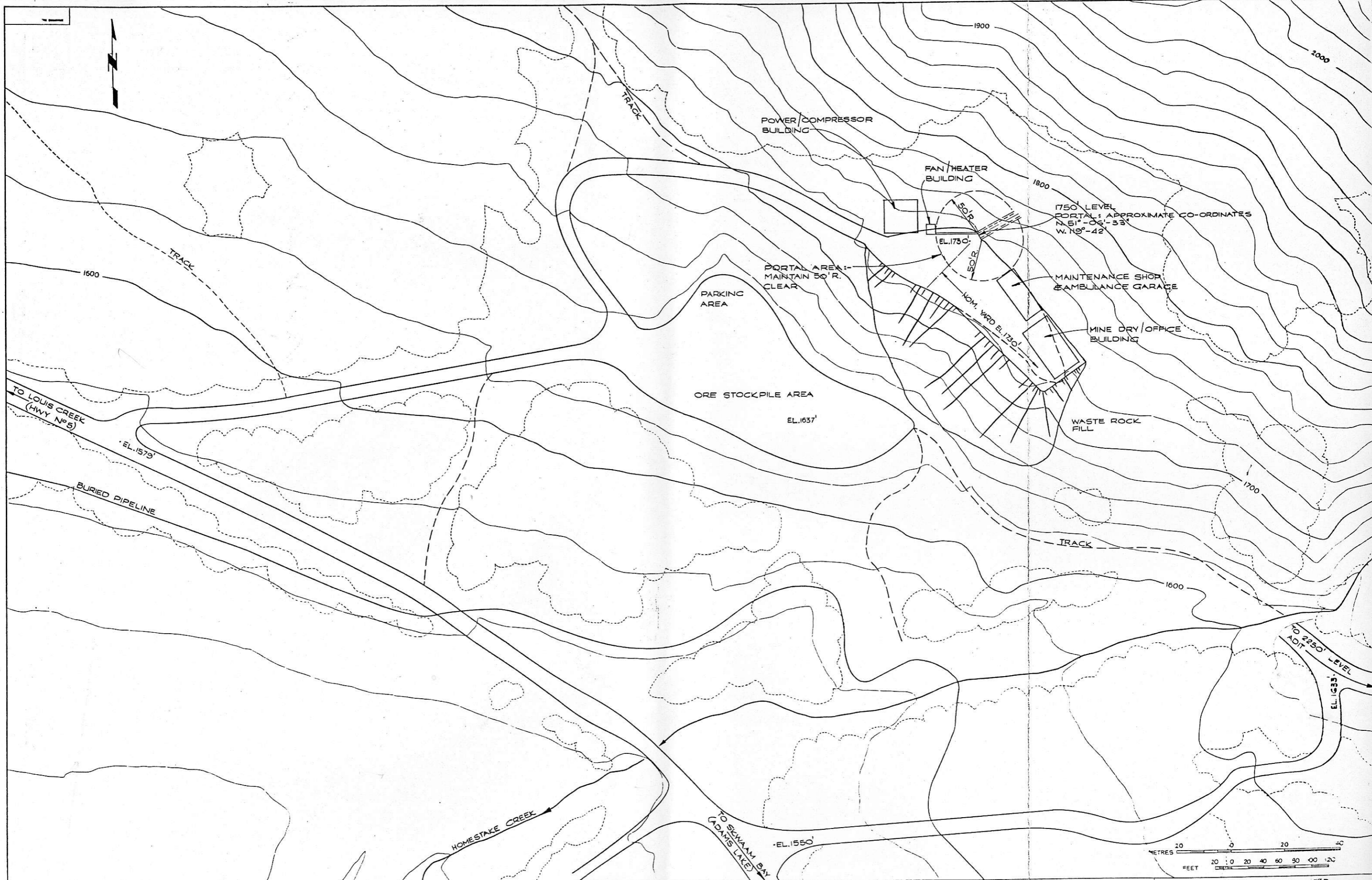

SECTION		SCALE 1:500		DATE		CLIENT CANAD SILVER CO LTD		TITLE		SHEET NO.	
DRAWN BY		E.A.S. DECA		DATE		LOCATION KAMLOOPS B.C.		HOMESTAKE PROPERTY		SHEET NO.	
CHECKED BY		P.A.S. DECA		DATE		PROJECT NO.		1750 LEVEL, PORTAL AREA		SHEET NO.	
APPROVED BY		P.A.S. DECA		DATE		PROJECT NO.		SITE PLAN		SHEET NO.	
DESCRIPTION		DATE		DESCRIPTION		DATE		DESCRIPTION		DATE	

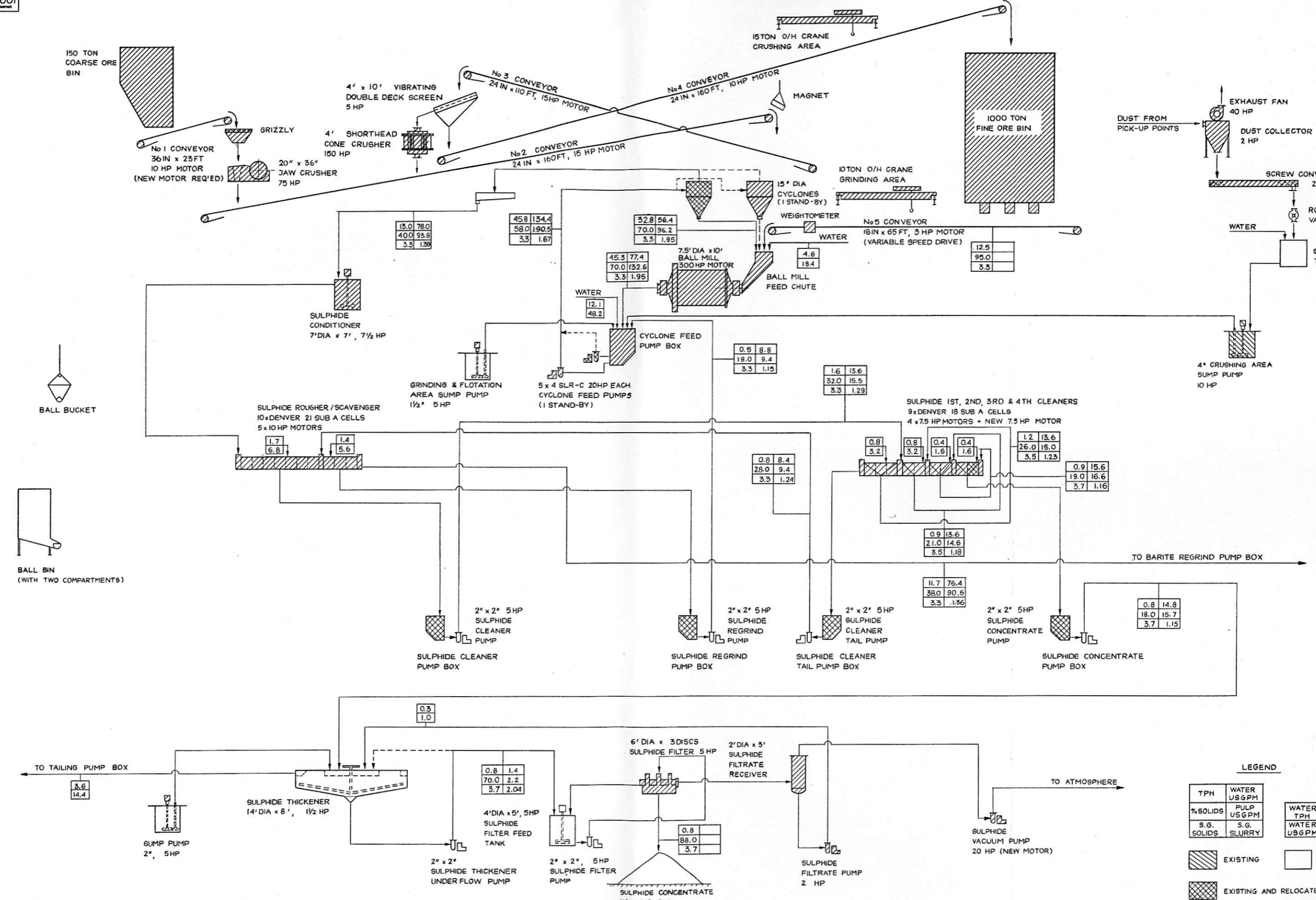

<table border="1" style="width:100%; border-collapse: collapse;"> <tr> <th>NO.</th> <th>DESCRIPTION</th> <th>DATE</th> <th>BY</th> </tr> <tr> <td> </td> <td> </td> <td> </td> <td> </td> </tr> <tr> <td> </td> <td> </td> <td> </td> <td> </td> </tr> </table>	NO.	DESCRIPTION	DATE	BY									<table border="1" style="width:100%; border-collapse: collapse;"> <tr> <td>SECTION:</td> <td>DATE:</td> </tr> <tr> <td>SCALE: NONE</td> <td>DEC. 82</td> </tr> <tr> <td>DESIGNED BY: F.Y.Y.</td> <td>CHECKED BY: Z.A.</td> </tr> <tr> <td>DRAWN BY: Z.A.</td> <td>APPROVED BY: J.B.F.</td> </tr> </table>	SECTION:	DATE:	SCALE: NONE	DEC. 82	DESIGNED BY: F.Y.Y.	CHECKED BY: Z.A.	DRAWN BY: Z.A.	APPROVED BY: J.B.F.
NO.	DESCRIPTION	DATE	BY																		
SECTION:	DATE:																				
SCALE: NONE	DEC. 82																				
DESIGNED BY: F.Y.Y.	CHECKED BY: Z.A.																				
DRAWN BY: Z.A.	APPROVED BY: J.B.F.																				
<table border="1" style="width:100%; border-collapse: collapse;"> <tr> <td>CLIENT:</td> <td>KAMAD SILVER CO. LTD.</td> </tr> <tr> <td>LOCATION:</td> <td>KAMLOOPS B.C.</td> </tr> <tr> <td colspan="2" style="text-align: center;"><b>KILBORN</b></td> </tr> </table>	CLIENT:	KAMAD SILVER CO. LTD.	LOCATION:	KAMLOOPS B.C.	<b>KILBORN</b>		<table border="1" style="width:100%; border-collapse: collapse;"> <tr> <td>TITLE:</td> <td>ACCT. NO.:</td> </tr> <tr> <td>MODIFIED DEKALB MILL FLOWSHEET - COMMINUTION AND SULPHIDE FLOTATION</td> <td>7560</td> </tr> <tr> <td></td> <td>DIVISION NO.:</td> </tr> <tr> <td></td> <td>16</td> </tr> <tr> <td></td> <td>DRAWING NUMBER:</td> </tr> <tr> <td></td> <td>100-03-F1</td> </tr> </table>	TITLE:	ACCT. NO.:	MODIFIED DEKALB MILL FLOWSHEET - COMMINUTION AND SULPHIDE FLOTATION	7560		DIVISION NO.:		16		DRAWING NUMBER:		100-03-F1		
CLIENT:	KAMAD SILVER CO. LTD.																				
LOCATION:	KAMLOOPS B.C.																				
<b>KILBORN</b>																					
TITLE:	ACCT. NO.:																				
MODIFIED DEKALB MILL FLOWSHEET - COMMINUTION AND SULPHIDE FLOTATION	7560																				
	DIVISION NO.:																				
	16																				
	DRAWING NUMBER:																				
	100-03-F1																				



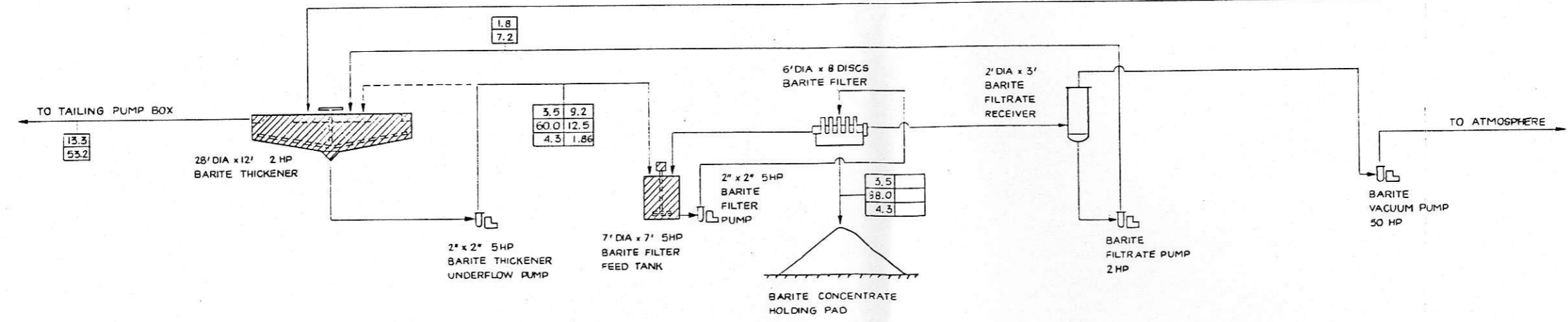
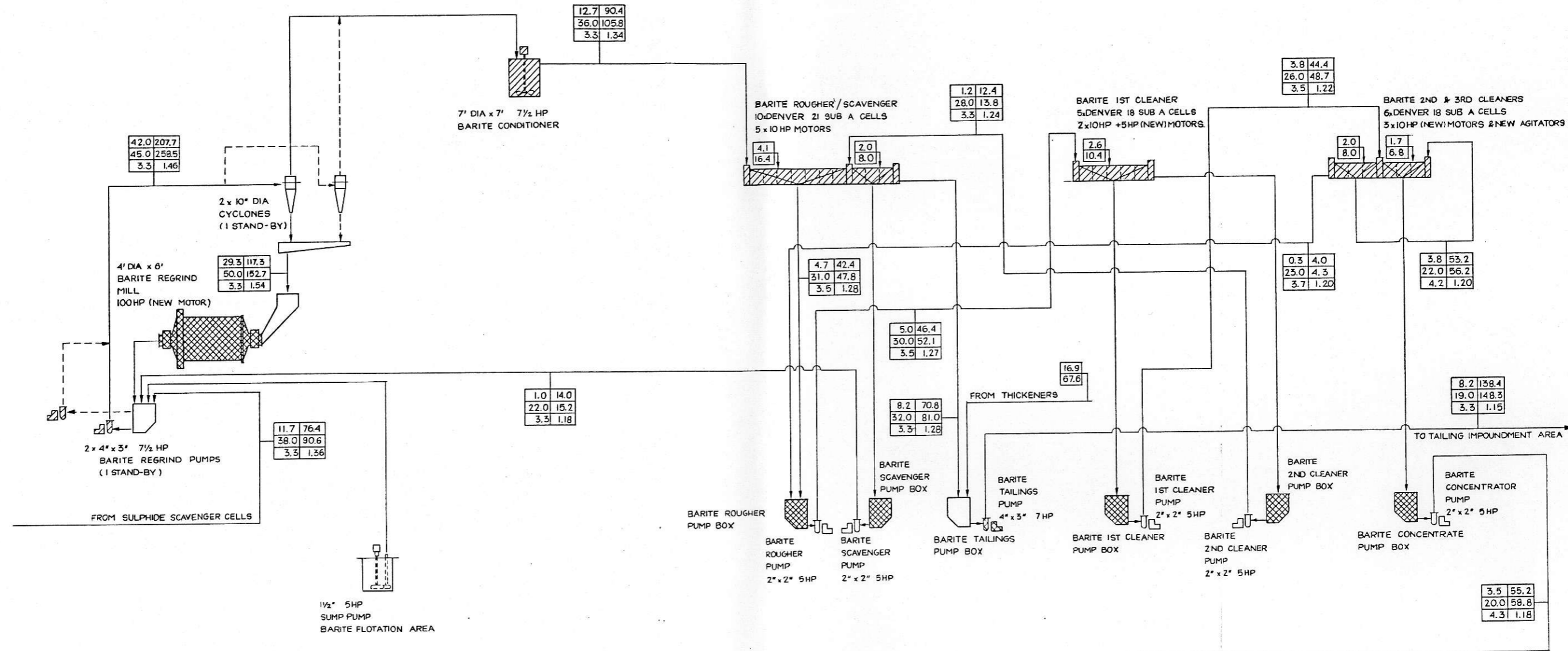

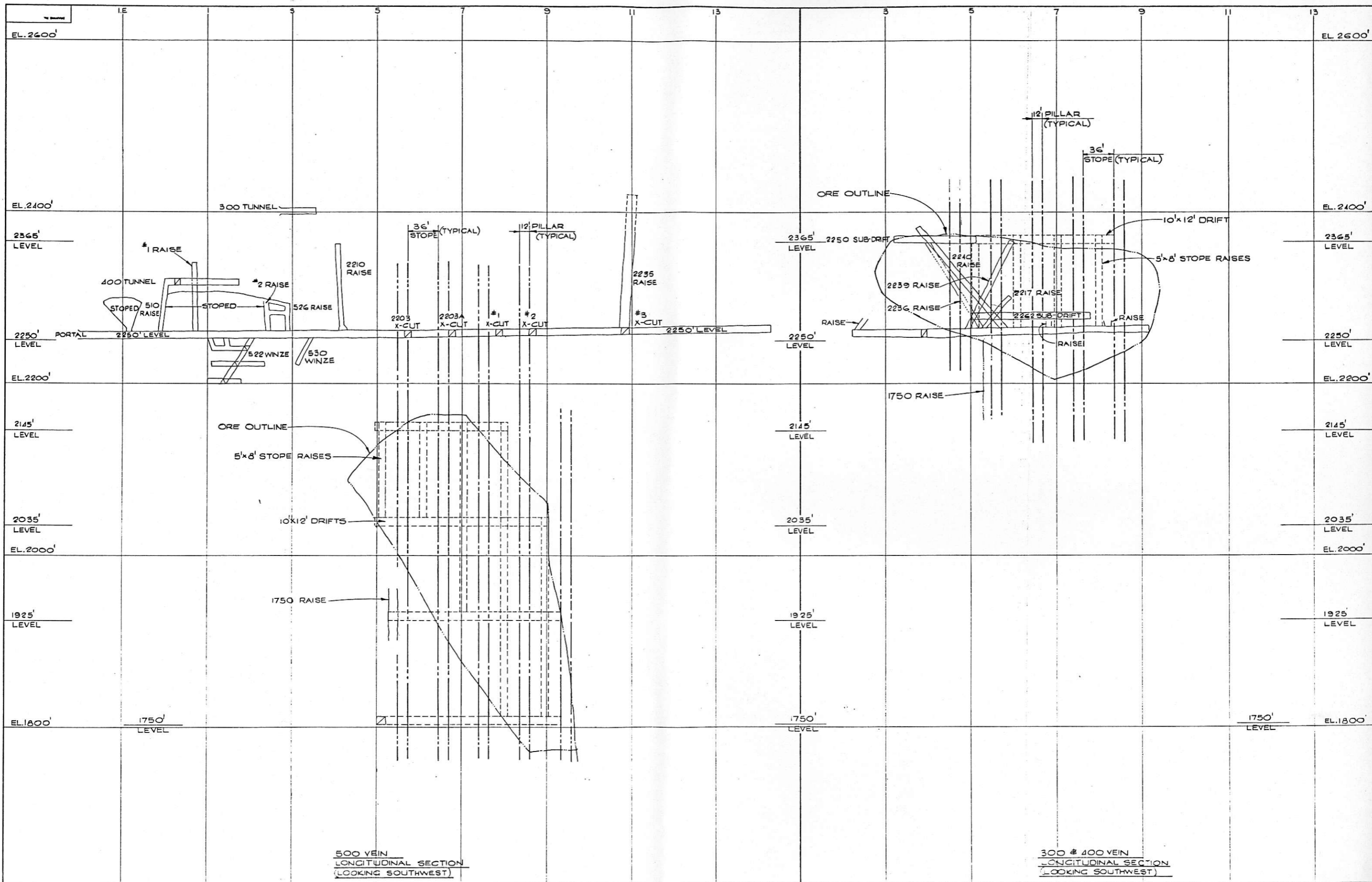

500 VEIN  
LONGITUDINAL SECTION  
(LOOKING SOUTHWEST)

300 & 400 VEIN  
LONGITUDINAL SECTION  
(LOOKING SOUTHWEST)

SECTION: 30' DATE:		CLIENT: KAMAD SILVER CO. LTD.		TITLE: HOMESTAKE PROPERTY		PROJECT NO: 7560	
DESIGNED BY: AES 2003		LOCATION: KAMLOOPS B.C.		300, 400 & 500 VEINS		DRAWN BY:	
CHECKED BY:		DATE:		LONGITUDINAL SECTIONS		000-05-27	

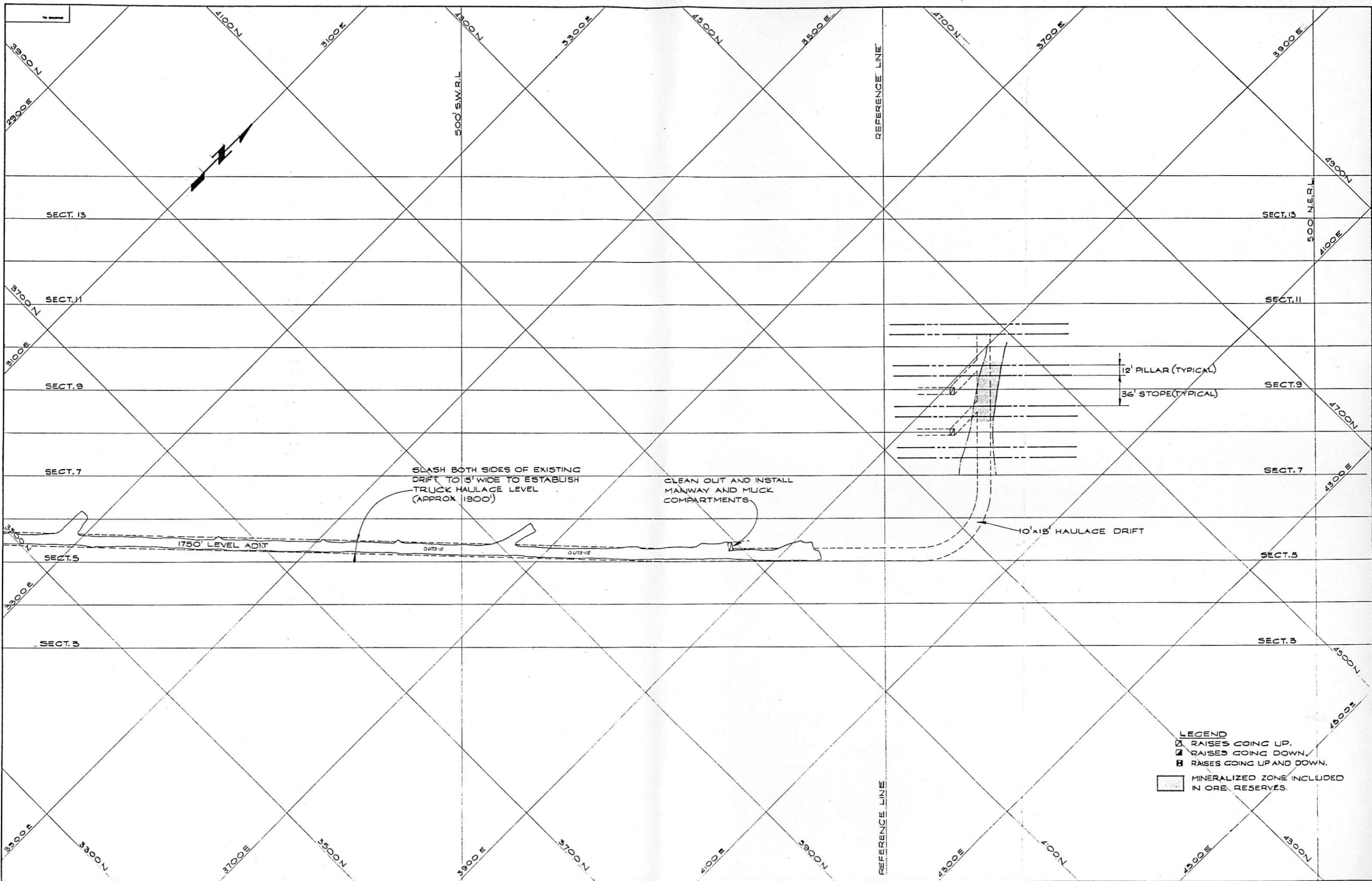

SLASH BOTH SIDES OF EXISTING DRIFT TO 15' WIDE TO ESTABLISH TRUCK HAULAGE LEVEL (APPROX 1900)

CLEAN OUT AND INSTALL MANWAY AND MUCK COMPARTMENTS

12' PILLAR (TYPICAL)  
36' STOPE (TYPICAL)

10'x15' HAULAGE DRIFT

**LEGEND**  
 □ RAISES GOING UP.  
 ▣ RAISES GOING DOWN.  
 ▤ RAISES GOING UP AND DOWN.  
 ■ MINERALIZED ZONE INCLUDED IN ORE RESERVES.

SECTION: 1750		DATE: DEC 30		PROJECT NO.: 7560-16		DRAWING NO.: 000-05-F8	
DESIGNED BY: A.E.S.		DRAWN BY: P.A.H.		PROJECT NO.: 7560-16		DRAWING NO.: 000-05-F8	
DESCRIPTION: 1750 LEVEL ADIT		DATE: DEC 30		PROJECT NO.: 7560-16		DRAWING NO.: 000-05-F8	
DESCRIPTION: 10'x15' HAULAGE DRIFT		DATE: DEC 30		PROJECT NO.: 7560-16		DRAWING NO.: 000-05-F8	
DESCRIPTION: 500' SW R.L.		DATE: DEC 30		PROJECT NO.: 7560-16		DRAWING NO.: 000-05-F8	
DESCRIPTION: 500' NE R.L.		DATE: DEC 30		PROJECT NO.: 7560-16		DRAWING NO.: 000-05-F8	
DESCRIPTION: REFERENCE LINE		DATE: DEC 30		PROJECT NO.: 7560-16		DRAWING NO.: 000-05-F8	
DESCRIPTION: 1750 LEVEL ADIT		DATE: DEC 30		PROJECT NO.: 7560-16		DRAWING NO.: 000-05-F8	
DESCRIPTION: 10'x15' HAULAGE DRIFT		DATE: DEC 30		PROJECT NO.: 7560-16		DRAWING NO.: 000-05-F8	
DESCRIPTION: 500' SW R.L.		DATE: DEC 30		PROJECT NO.: 7560-16		DRAWING NO.: 000-05-F8	
DESCRIPTION: 500' NE R.L.		DATE: DEC 30		PROJECT NO.: 7560-16		DRAWING NO.: 000-05-F8	
DESCRIPTION: REFERENCE LINE		DATE: DEC 30		PROJECT NO.: 7560-16		DRAWING NO.: 000-05-F8	

CANAD SILVER CO. LTD.  
 AMLOOPS B.C.  
**MILBORN**  
 TITLE: HOMESTAKE PROPERTY 1750 LEVEL DEVELOPMENT PLAN

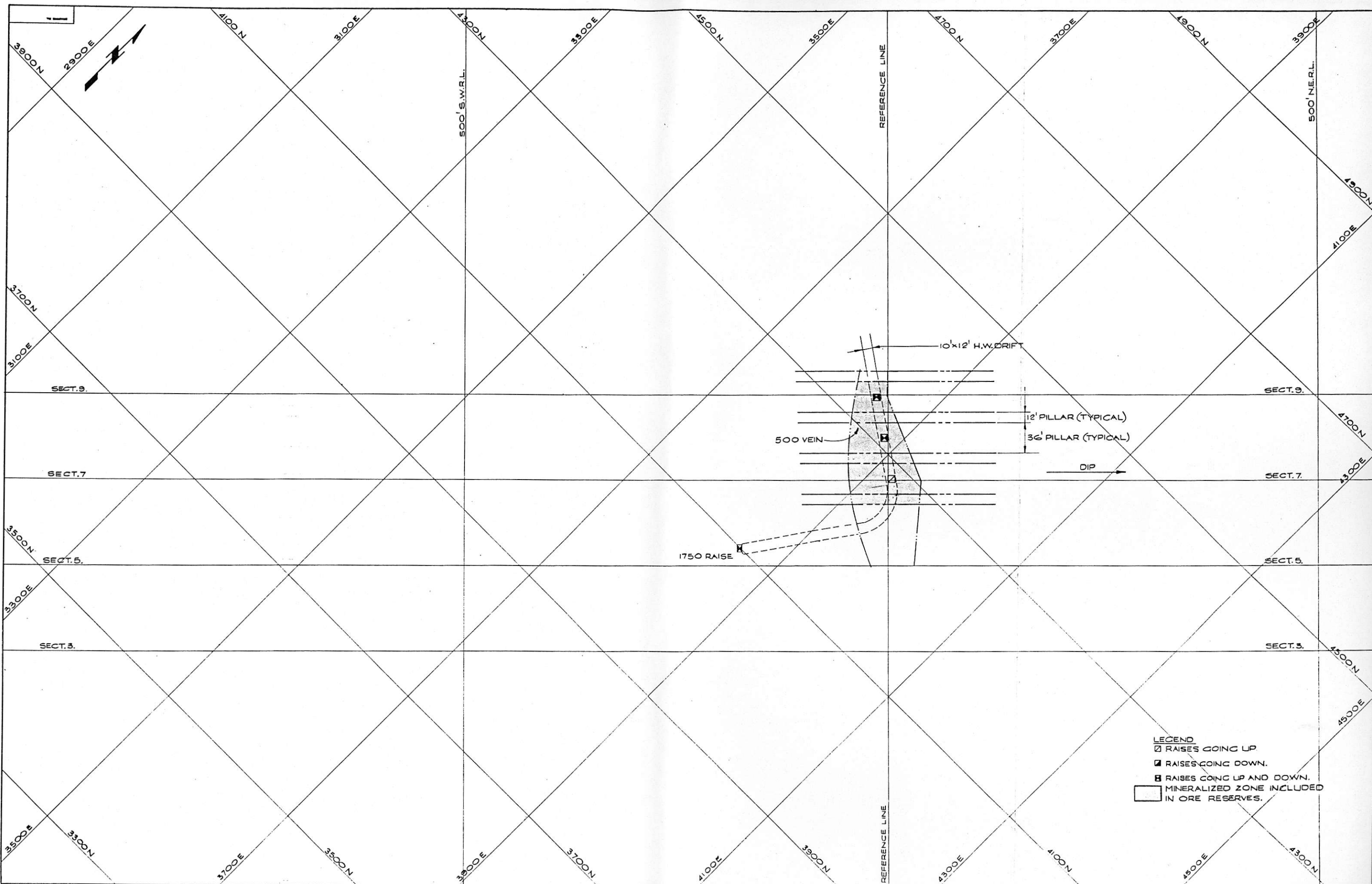

**LEGEND**  
 □ RAISES GOING UP  
 ▣ RAISES GOING DOWN.  
 ▤ RAISES GOING UP AND DOWN.  
 ▭ MINERALIZED ZONE INCLUDED IN ORE RESERVES.

SECTION		DATE		DRAWN BY		CHECKED BY		DATE		PROJECT NO.		SHEET NO.	
SCALE 1" = 30'		DATE		A.E.S. DEC. 3, 1960		P.A.H. DEC. 3, 1960				KILBORN		7560 16	
DESIGNER										TITLE			
KILBORN										HOMESTAKE PROPERTY 1925' LEVEL DEVELOPMENT PLAN			
PROJECT NO.										200-C3-F9			

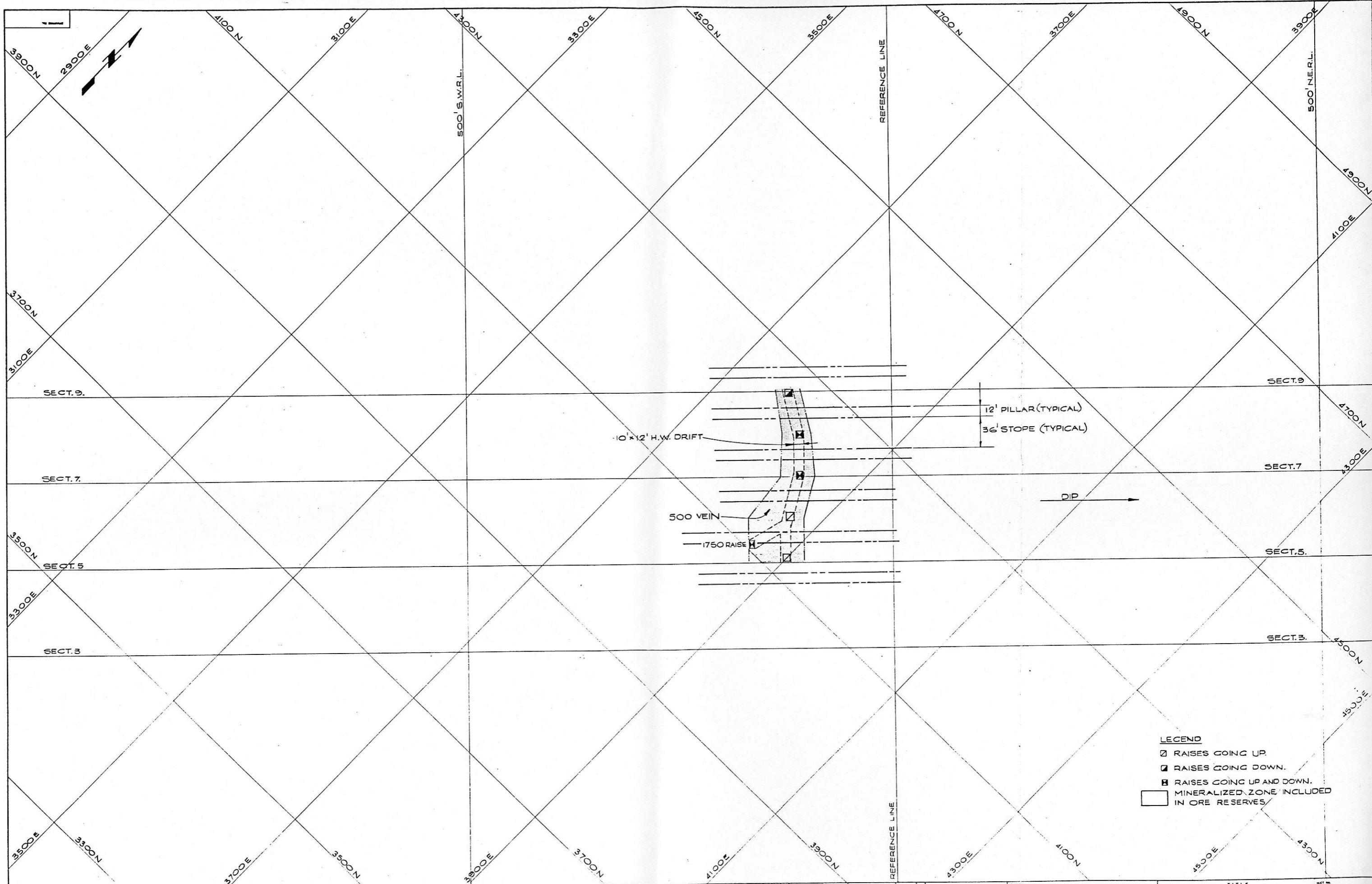

- LEGEND**
- ☐ RAISES GOING UP.
  - ☑ RAISES GOING DOWN.
  - ⊠ RAISES GOING UP AND DOWN.
  - ▨ MINERALIZED ZONE INCLUDED IN ORE RESERVES.

SECTION SCALE 1" = 10' DRAWN BY A.E. SECOR CHECKED BY P.A.H. DEC 76		CLIENT CANAD SILVER CO. LTD. KAMLOOPS B.C.		TITLE HOMESTAKE PROPERTY 2035' LEVEL DEVELOPMENT PLAN		SHEET NO. 7560	
DATE 1976		PROJECT NO. 200-05-10		DRAWING NUMBER 200-05-10		SHEET NO. 7560	

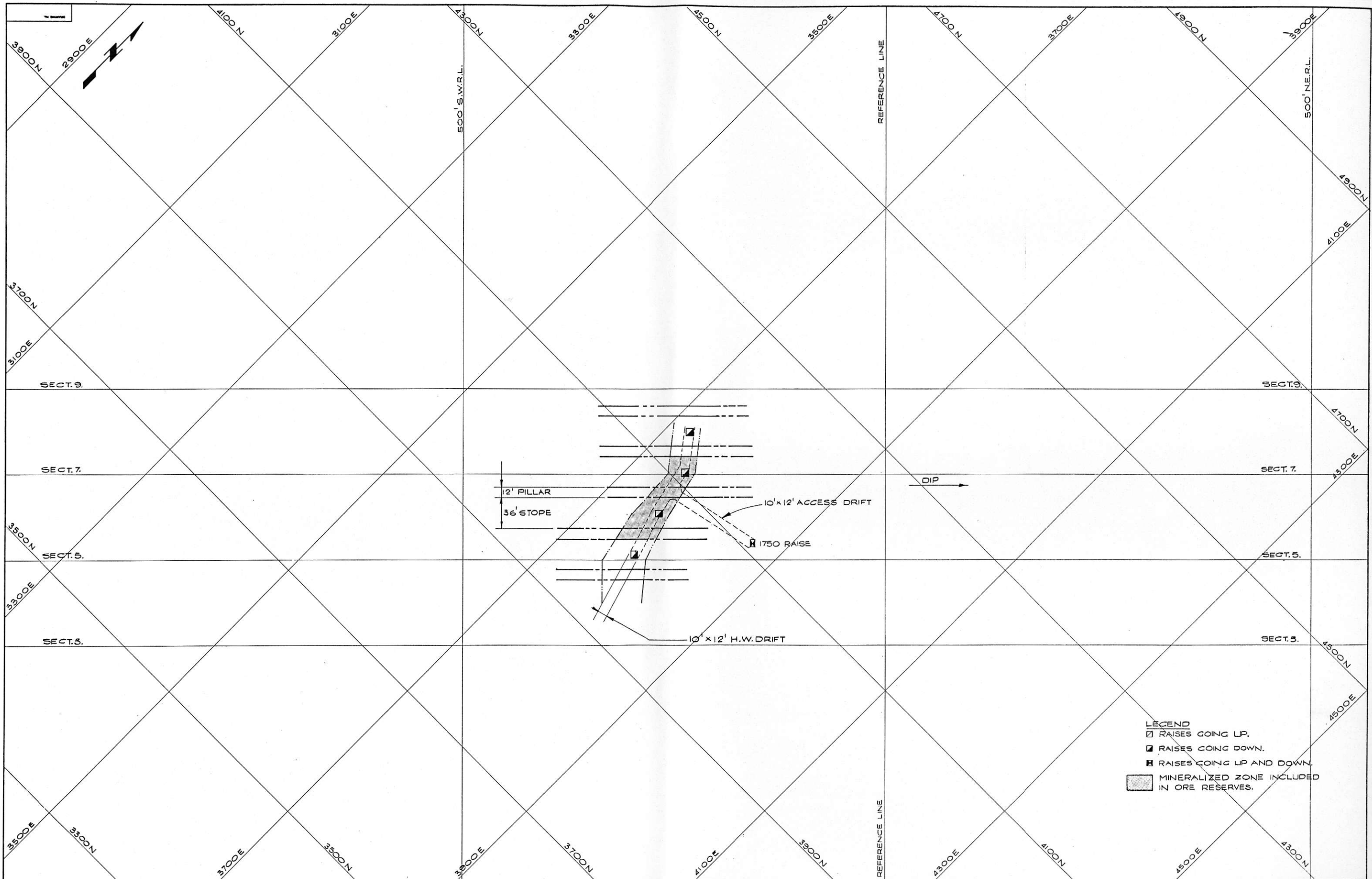

**LEGEND**  
 □ RAISES GOING UP.  
 ▣ RAISES GOING DOWN.  
 ◐ RAISES GOING UP AND DOWN.  
 ■ MINERALIZED ZONE INCLUDED IN ORE RESERVES.

SECTION: SCALE: 1" = 40' DESIGNED BY: A.E.S. DEC. 82 DRAWN BY: P.A.H. DEC 82 APPROVED BY: JBF	CLIENT: KAMAD SILVER CO. LTD. LOCATION: KAMLOOPS B.C.	TITLE: HOMESTAKE PROPERTY 2145' LEVEL DEVELOPMENT PLAN	PROJECT NO: 7560 DIVISION NO: 16 DRAWING NUMBER: 200-05-F11
---	---	---	--



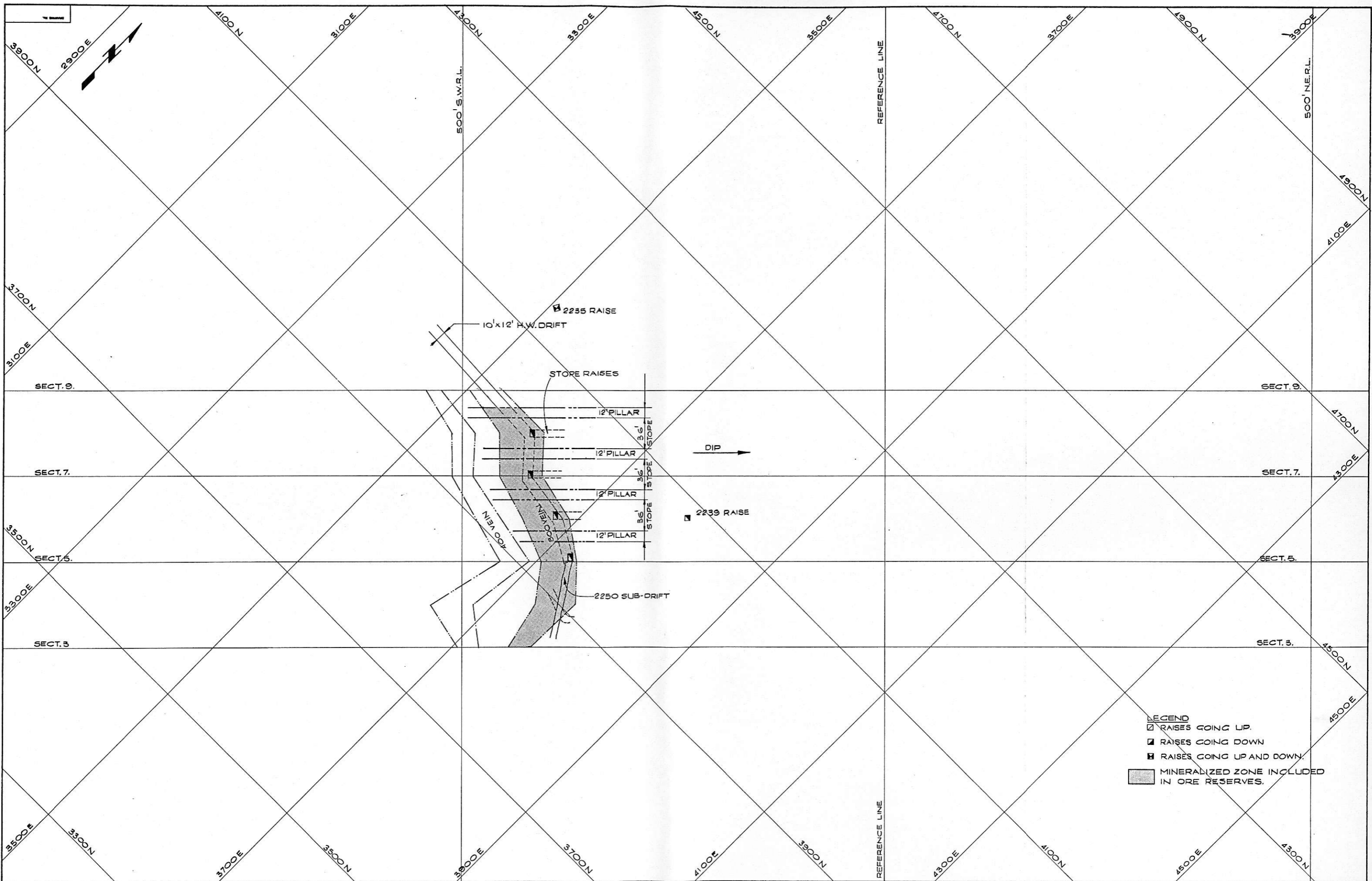

- LEGEND**
- ☐ RAISES GOING UP.
  - ▣ RAISES GOING DOWN.
  - ◻ RAISES GOING UP AND DOWN.
  - MINERALIZED ZONE INCLUDED IN ORE RESERVES.

<table border="1" style="width: 100%; border-collapse: collapse;"> <tr> <th>NO.</th> <th>DESCRIPTION</th> <th>DATE</th> <th>BY</th> </tr> <tr> <td> </td> <td> </td> <td> </td> <td> </td> </tr> <tr> <td> </td> <td> </td> <td> </td> <td> </td> </tr> </table>	NO.	DESCRIPTION	DATE	BY									<table border="1" style="width: 100%; border-collapse: collapse;"> <tr> <th>NO.</th> <th>DESCRIPTION</th> <th>DATE</th> <th>BY</th> </tr> <tr> <td> </td> <td> </td> <td> </td> <td> </td> </tr> <tr> <td> </td> <td> </td> <td> </td> <td> </td> </tr> </table>	NO.	DESCRIPTION	DATE	BY									<table border="1" style="width: 100%; border-collapse: collapse;"> <tr> <th>NO.</th> <th>DESCRIPTION</th> <th>DATE</th> <th>BY</th> </tr> <tr> <td> </td> <td> </td> <td> </td> <td> </td> </tr> <tr> <td> </td> <td> </td> <td> </td> <td> </td> </tr> </table>	NO.	DESCRIPTION	DATE	BY									<table border="1" style="width: 100%; border-collapse: collapse;"> <tr> <td>SECTION:</td> <td>1" = 40'</td> <td>DATE:</td> <td>DEC. 82</td> </tr> <tr> <td>DESIGNED BY:</td> <td>A.E.S.</td> <td>CHECKED BY:</td> <td>P.A.H.</td> </tr> <tr> <td>DRAWN BY:</td> <td>P.A.H.</td> <td>APPROVED BY:</td> <td>JBF</td> </tr> </table>	SECTION:	1" = 40'	DATE:	DEC. 82	DESIGNED BY:	A.E.S.	CHECKED BY:	P.A.H.	DRAWN BY:	P.A.H.	APPROVED BY:	JBF	<table border="1" style="width: 100%; border-collapse: collapse;"> <tr> <td>CLIENT:</td> <td>KAMAD SILVER CO. LTD.</td> </tr> <tr> <td>LOCATION:</td> <td>KAMLOOPS B.C.</td> </tr> </table>	CLIENT:	KAMAD SILVER CO. LTD.	LOCATION:	KAMLOOPS B.C.	<table border="1" style="width: 100%; border-collapse: collapse;"> <tr> <td>TITLE:</td> <td>HOMESTAKE PROPERTY 2365' LEVEL DEVELOPMENT PLAN</td> </tr> </table>	TITLE:	HOMESTAKE PROPERTY 2365' LEVEL DEVELOPMENT PLAN	<table border="1" style="width: 100%; border-collapse: collapse;"> <tr> <td>PROJECT NO.</td> <td>7560</td> <td>DIVISION NO.</td> <td>16</td> </tr> <tr> <td>DRAWING NUMBER</td> <td colspan="3">200-05-F13</td> </tr> </table>	PROJECT NO.	7560	DIVISION NO.	16	DRAWING NUMBER	200-05-F13		
NO.	DESCRIPTION	DATE	BY																																																																	
NO.	DESCRIPTION	DATE	BY																																																																	
NO.	DESCRIPTION	DATE	BY																																																																	
SECTION:	1" = 40'	DATE:	DEC. 82																																																																	
DESIGNED BY:	A.E.S.	CHECKED BY:	P.A.H.																																																																	
DRAWN BY:	P.A.H.	APPROVED BY:	JBF																																																																	
CLIENT:	KAMAD SILVER CO. LTD.																																																																			
LOCATION:	KAMLOOPS B.C.																																																																			
TITLE:	HOMESTAKE PROPERTY 2365' LEVEL DEVELOPMENT PLAN																																																																			
PROJECT NO.	7560	DIVISION NO.	16																																																																	
DRAWING NUMBER	200-05-F13																																																																			



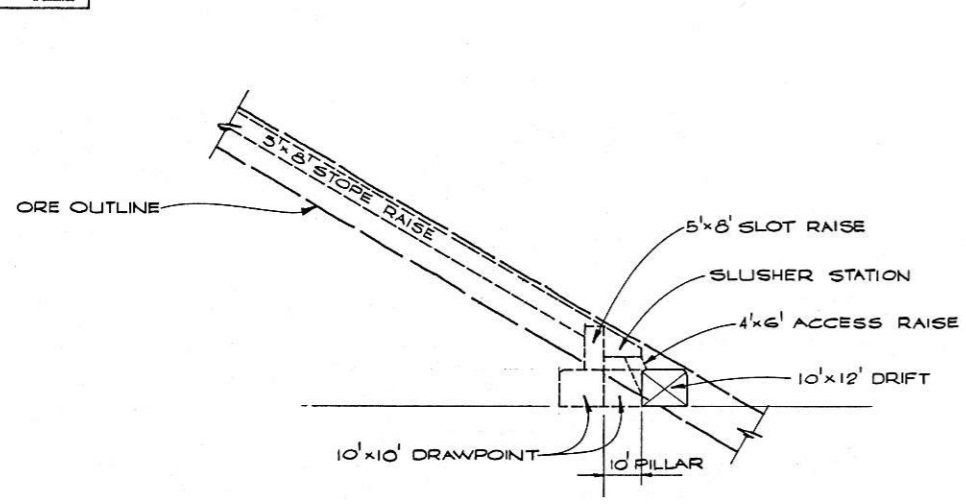

DEVELOPMENT- NARROW STOPE

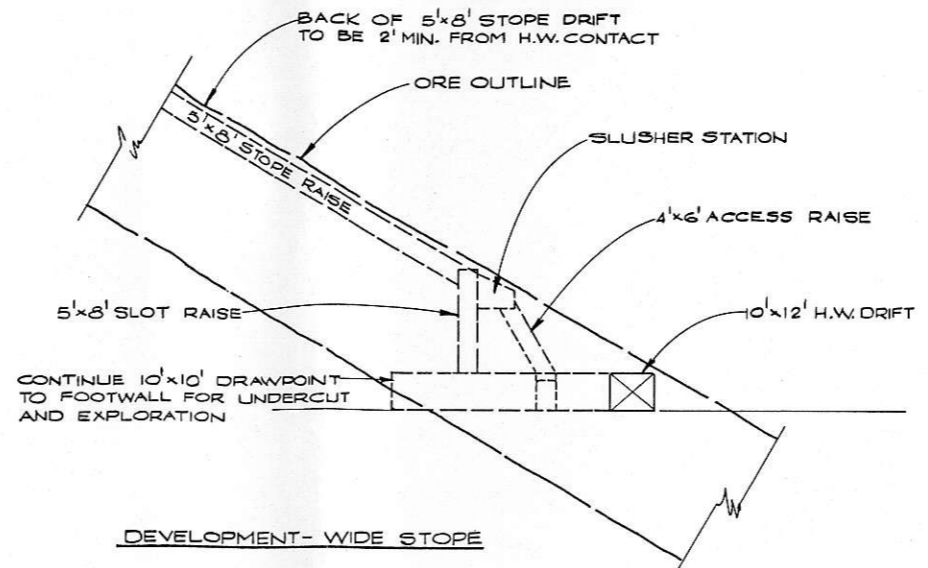

DEVELOPMENT- WIDE STOPE

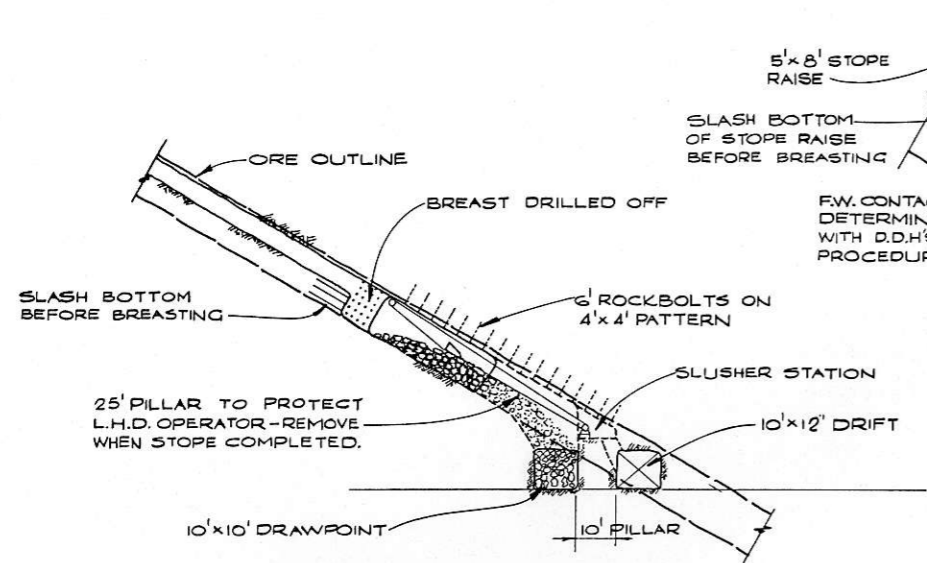

OPERATION- NARROW STOPE

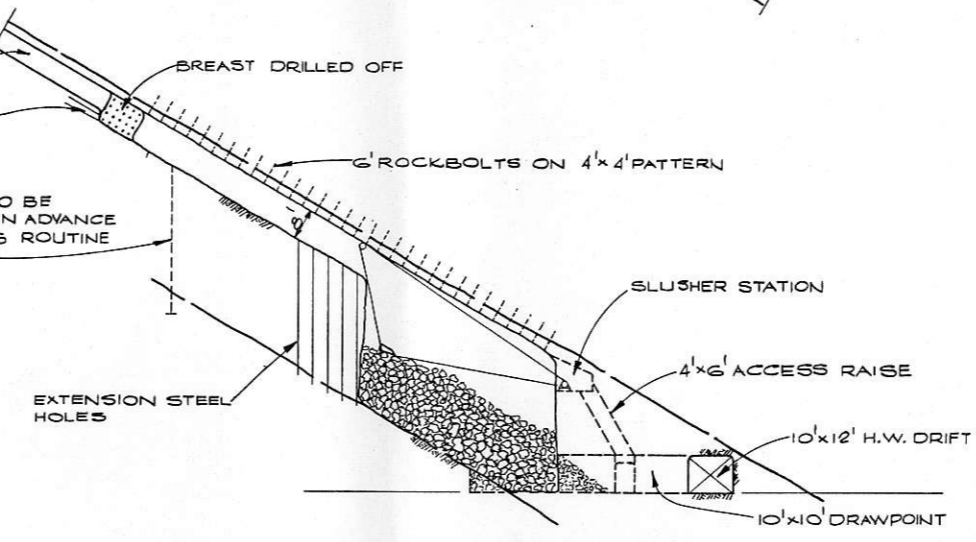

OPERATION - WIDE STOPE

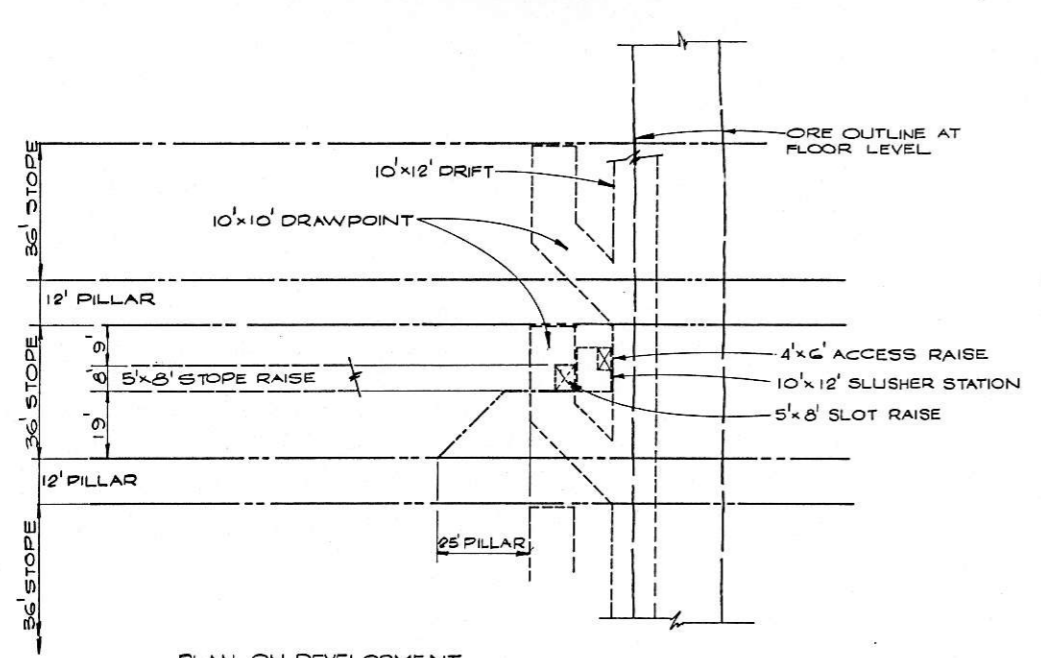

PLAN ON DEVELOPMENT NARROW STOPE

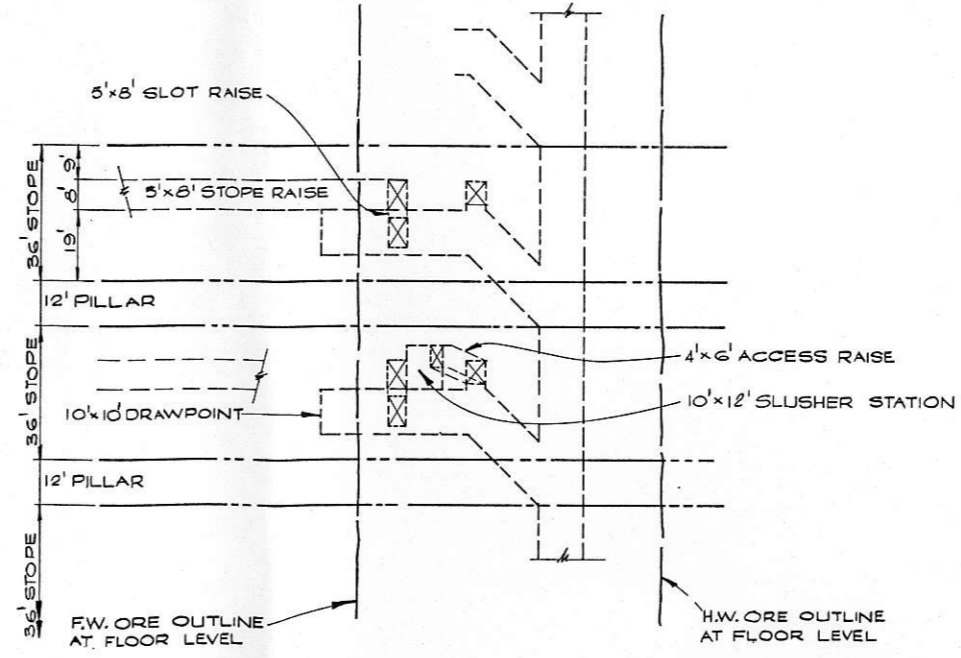

PLAN ON DEVELOPMENT WIDE STOPE

SECTION: MINING										CLIENT: KAMAD SILVER CO. LTD.										TITLE: HOMESTAKE PROPERTY MINING AND STOPE DEVELOPMENT DETAILS									
SCALE: 1" = 20'										DATE: DEC. 7.82										PROJECT NO: 7560									
DESIGNED BY: R.M.S.										DRAWN BY: P.A.H.										DIVISION NO: 16									
CHECKED BY: J.B.F.										APPROVED BY: J.B.F.										DRAWING NUMBER: 200-05-F14									
NO. DESCRIPTION DATE BY										NO. DESCRIPTION DATE BY										NO. DESCRIPTION DATE BY									

DESCRIPTION	QUANTITY	SHIFTS PER DAY	CREW SIZE	WEEKS																																																												
				1	2	3	4	5	6	7	8	9	10	11	12	13	14	15	16	17	18	19	20	21	22	23	24	25	26	27	28	29	30	31	32	33	34																											
1750 LEVEL ENLARGING :	1900'	3	3																																																													
GROUND SUPPORT	540'																																																															
TIMBER	540'																																																															
1750 X-CUT :	280'	3	2																																																													
DRIFT	200'																																																															
DIAMOND DRILLING																																																																
1750 RAISE :	447'																																																															
REHABILITATION TOP		3	2																																																													
MUCK OUT RAISE		1	1																																																													
TIMBER		3	2																																																													
EXCAVATION - 3 STATIONS :	6000 FT <sup>3</sup>	3	2																																																													
INSTALL CHUTE		1	2																																																													
INSTALL MILLHOLE		3	2																																																													
2250 LEVEL ENLARGING & REHABIL.	1040'	3	2																																																													
2250 STOPE DEVELOPMENT :																																																																
3 DRAWPOINTS	90'	3	2																																																													
3 SLOT & 3 MANWAY RAISES	90'	3	2																																																													
3 SLUSHER STATIONS	45'	3	2																																																													
3 STOPE RAISES	660'	3	2																																																													
2365 LEVEL	100'	3	2																																																													
1750 STOPE DEVELOPMENT :																																																																
2 DRAWPOINTS	60'	3	2																																																													
2 SLOT RAISES	60'	3	2																																																													
2 SLUSHER STATIONS	30'	3	2																																																													
2 SLOT RAISES	440'	3	2																																																													
2365 LEVEL	150'	3	2																																																													
2250:300 VEIN No.1 STOPE		3	2																																																													
300 VEIN No.2 STOPE		3	2																																																													
300 VEIN No.3 STOPE																																																																
1750:500 VEIN No.1 STOPE																																																																
500 VEIN No.2 STOPE																																																																
ONGOING DEVELOPMENT																																																																
ORE PRODUCED (TONS)																																																																

———— WASTE ROCK  
 ----- ORE

START OF FULL PRODUCTION

3 SHIFTS DAY  
 2 SHIFTS DAY

CLIENT KAMAD SILVER CO LTD  
 LOCATION KAMLOOPS B.C.

HOMESTAKE PROPERTY  
 MINE DEVELOPMENT SCHEDULE

**KILBORN**

PROJ. NO. 7560-16    DWG. NO. 200-26-F1    REV.

K.B.C. 9

REVISIONS

NO.    DATE    BY    APPROVED J.B.F.

SCALE  
 DESIGNED J.B.F.    DATE DEC.82  
 DRAWN Z.A.    DATE DEC.82  
 CHECKED

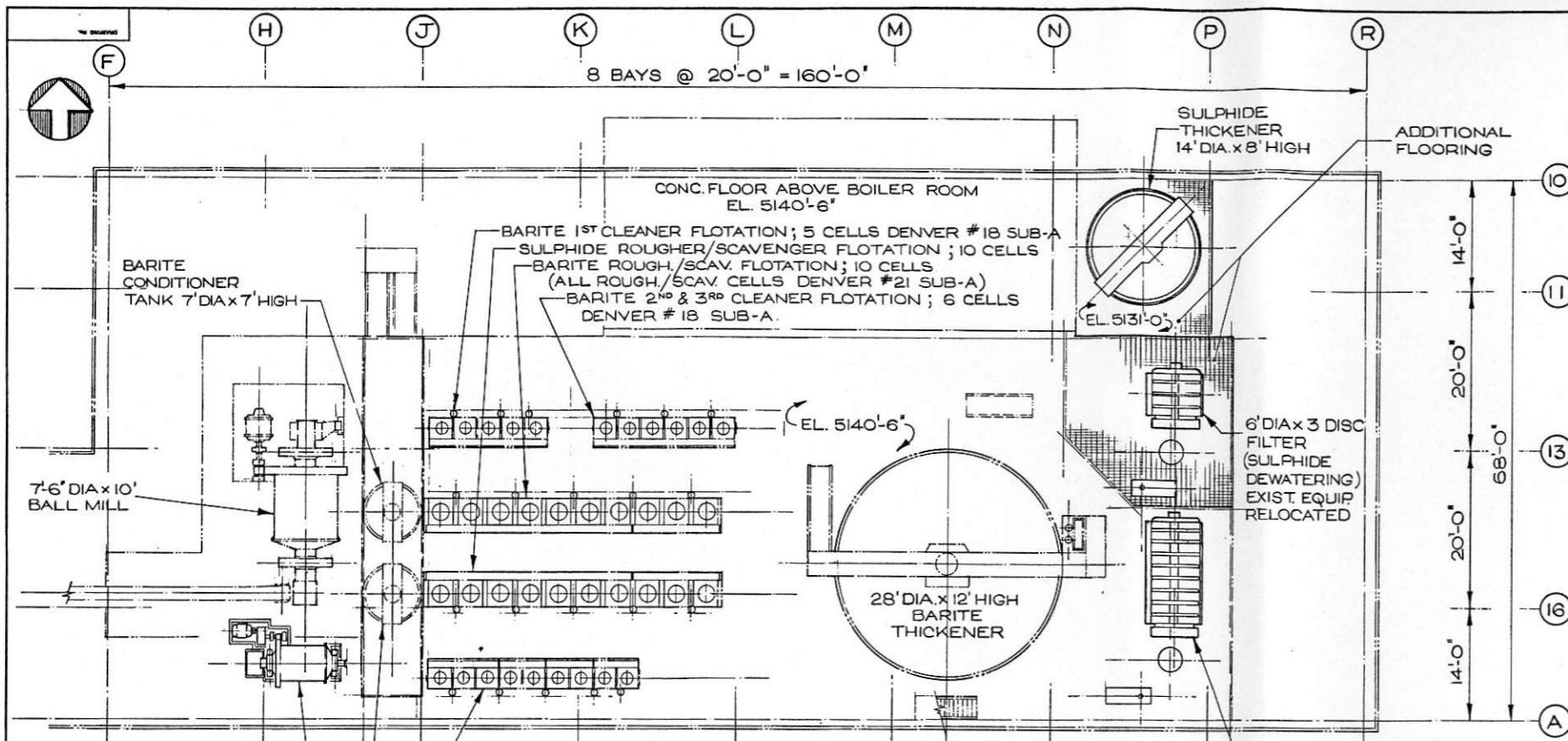

PLAN: OPERATING FLOOR

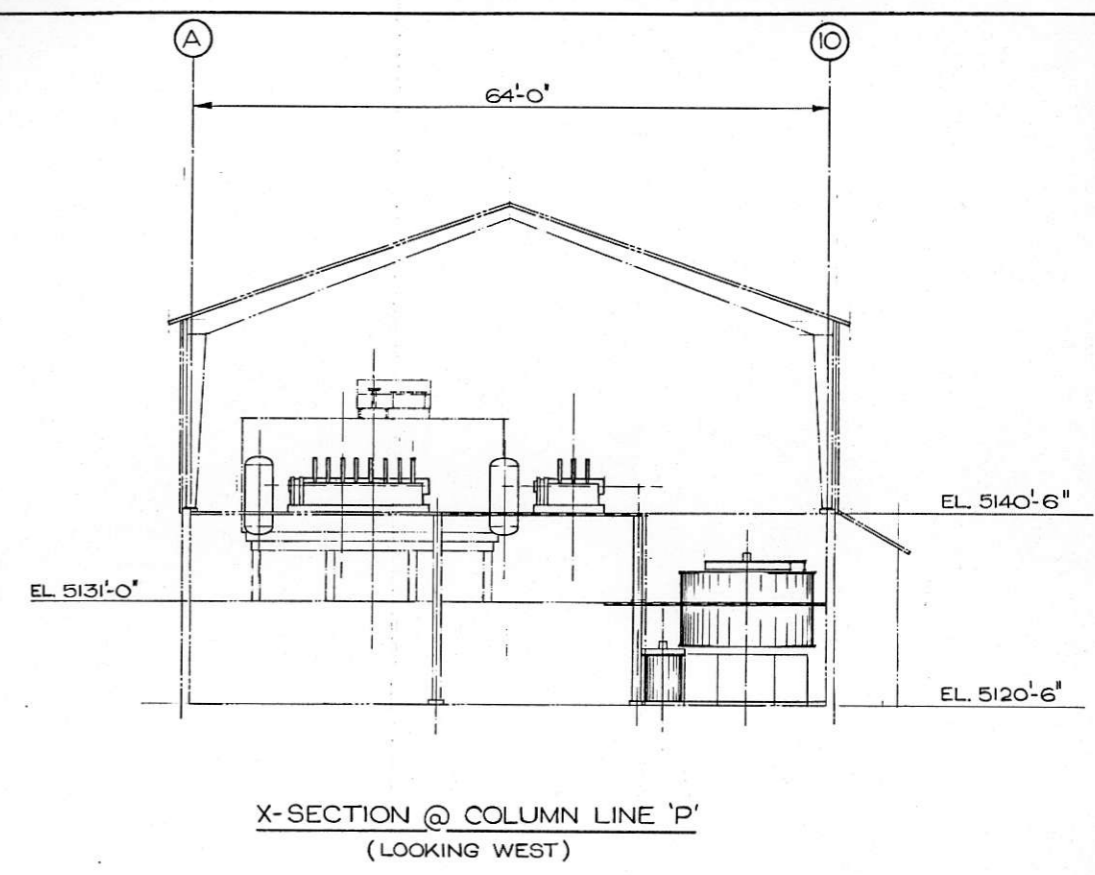

X-SECTION @ COLUMN LINE 'P'  
(LOOKING WEST)

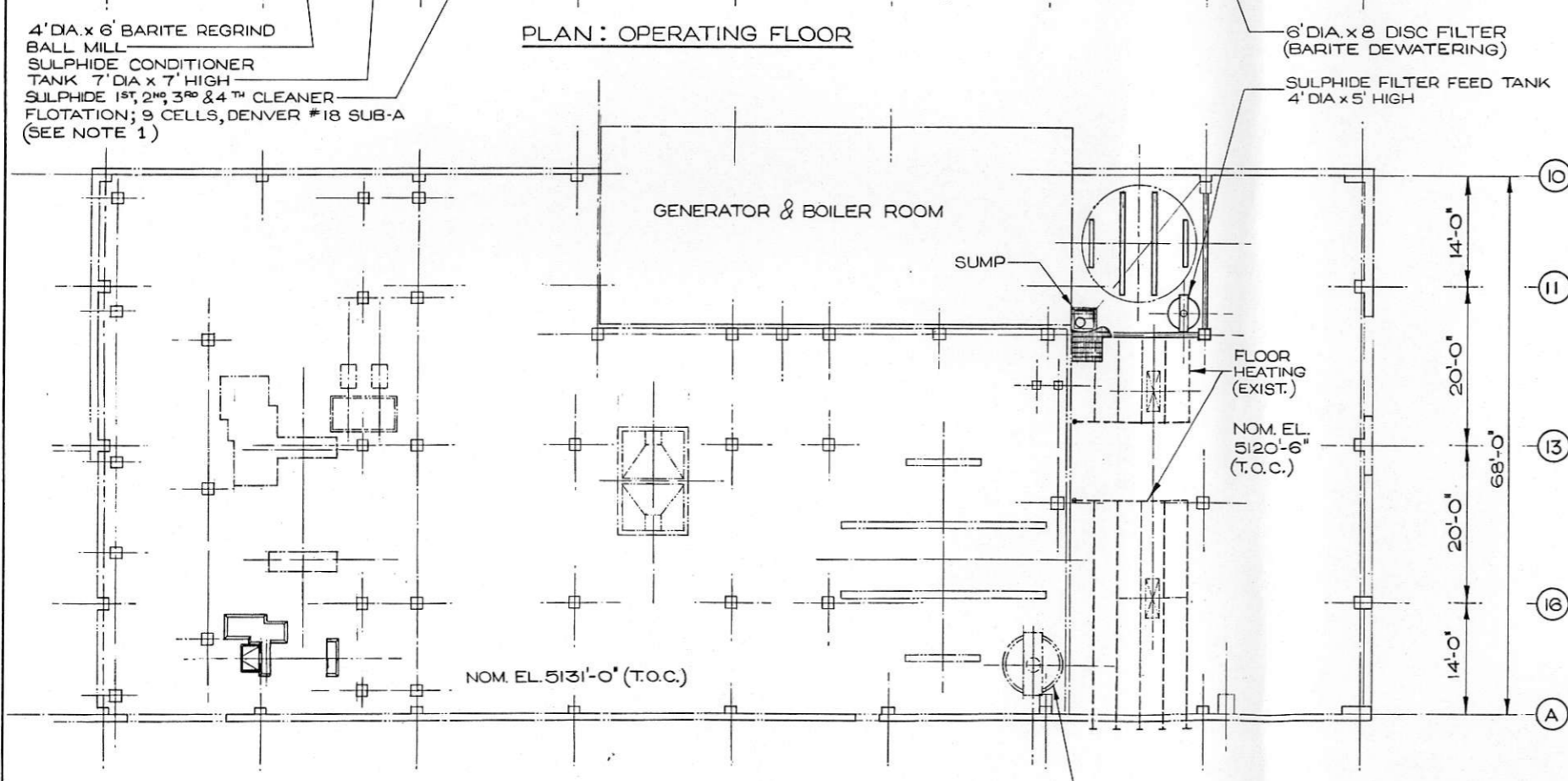

PLAN: GROUND FLOOR

**LEGEND**  
 [Symbol] INDICATES EXISTING EQUIPMENT OR STRUCTURE  
 [Symbol] INDICATES NEW FOUNDATIONS

**NOTES**  
 1 THIS BANK CONSISTS OF 8 CELLS ORIGINALLY IN THIS POSITION PLUS ONE CELL TRANS-FERRED FROM BANK NOW USED AS BARITE 1ST CLEANERS

SECTION: GENERAL LAYOUT		CLIENT: KAMAD SILVER CO. LTD	TITLE: HOMESTAKE PROPERTY CONCENTRATOR GENERAL ARRANGEMENT	ASCT NO.
SCALE: 1/8" = 1'-0"	DATE: DEC 82	LOCATION: KAMLOOPS B.C.	PROJECT NO. 7560	DIVISION NO. 16
DESIGNED BY: J.B.C.	CHECKED BY: J.B.C.	APPROVED BY: JBF	DRAWING NUMBER	300-10-F1
KILBORN				

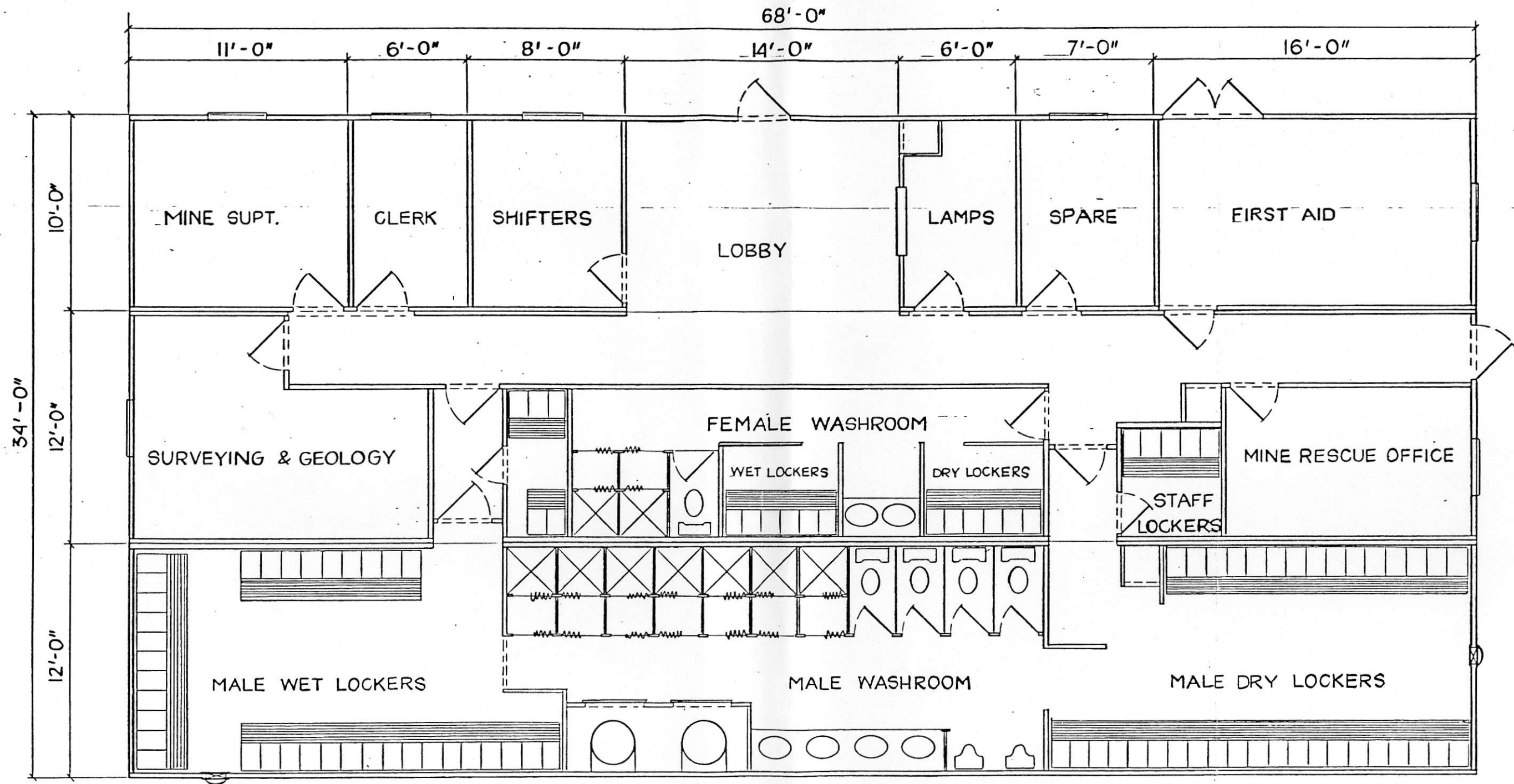

REVISIONS NO    DATE    BY	SCALE N.T.S. DESIGNED	DATE DEC. 82	CLIENT KAMAD SILVER CO. LTD.	HOMESTAKE PROPERTY MINE OFFICE / CHANGEHOUSE PROJ. NO 7560-16    DWG. NO 400-10-F1    REV.	
	DRAWN ZA	CHECKED	LOCATION KAMLOOPS B.C.		
	APPROVED JBF				<b>KILBORN</b>

K.E.B.C. 9

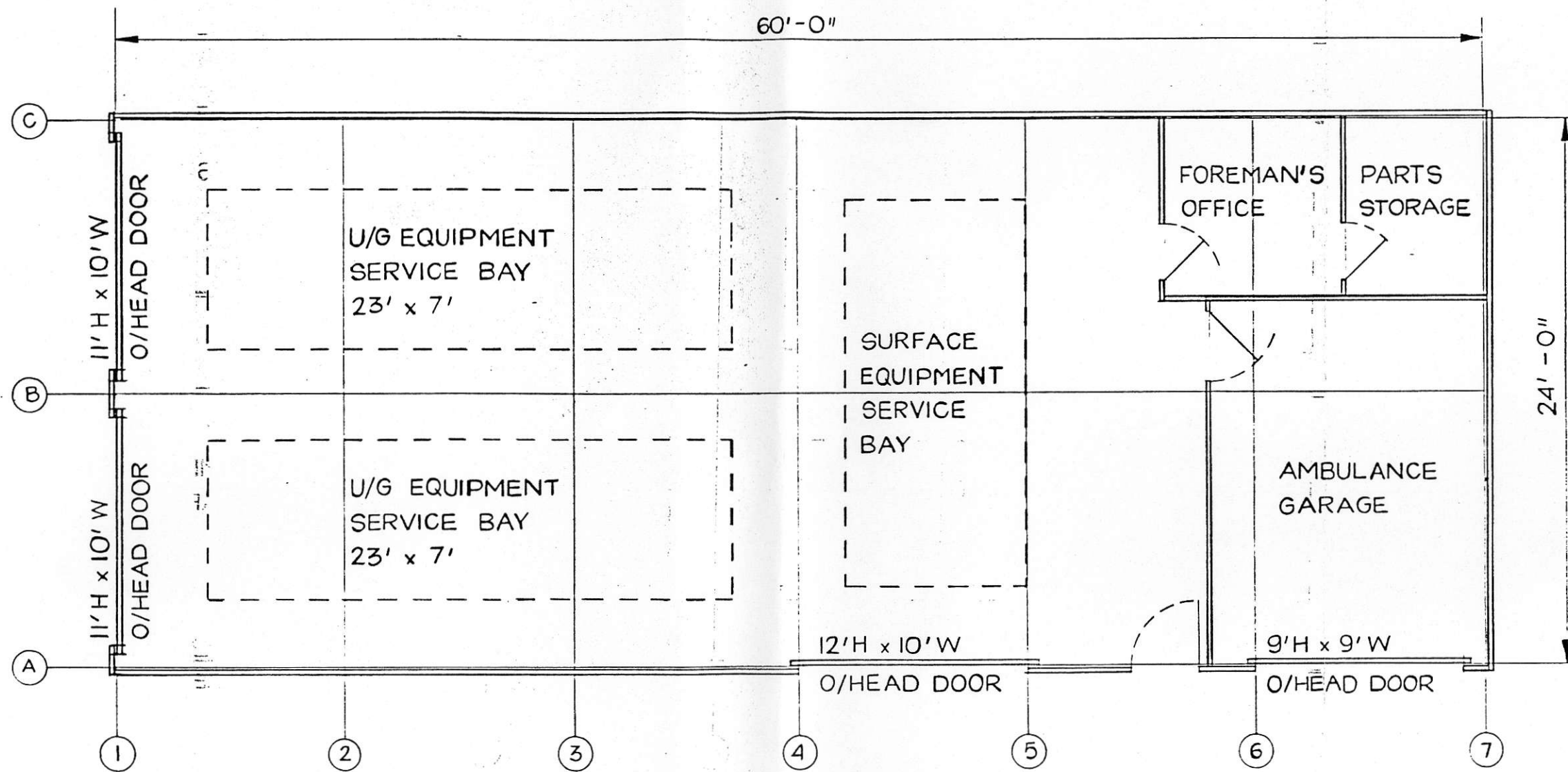

REVISIONS	NO	DATE	BY	APPROVED	J.B.F	SCALE	1:60	DATE	DEC.82	CLIENT	KAMAD SILVER CO. LTD.	HOMESTAKE PROPERTY MINE MAINTENANCE SHOP	
				DESIGNED	E.A.S.			DATE	DEC.82	LOCATION	KAMLOOPS B.C.		
				DRAWN	Z.A.			DATE	DEC.82	<div style="text-align: center; font-size: 2em; font-weight: bold;">KILBORN</div>			
				CHECKED									PROJ. NO

KEBC.9