

93L

MEMORANDUM ON THE
INDUCED POLARIZATION
AND RESISTIVITY RESULTS
ON THE
NEW SHEEDY CREEK PROPERTY,
ANOMALY 7,
BULKLEY VALLEY, B.C. **812159**
FOR
SEARCHLIGHT EXPLORATION CORPORATION

McPHAR GEOPHYSICS

NOTES ON THE THEORY, METHOD OF FIELD OPERATION AND PRESENTATION OF DATA FOR THE INDUCED POLARIZATION METHOD

Induced Polarization as a geophysical measurement refers to the blocking action or polarization of metallic or electronic conductors in a medium of ionic solution conduction.

This electro-chemical phenomenon occurs wherever electrical current is passed through an area which contains metallic minerals such as base metal sulphides. Normally, when current is passed through the ground, as in resistivity measurements, all of the conduction takes place through ions present in the water content of the rock, or soil, i. e. by ionic conduction. This is because almost all minerals have a much higher specific resistivity than ground water. The group of minerals commonly described as "metallic", however, have specific resistivities much lower than ground waters. The induced polarization effect takes place at those interfaces where the mode of conduction changes from ionic in the solutions filling the interstices of the rock to electronic in the metallic minerals present

in the rock.

The blocking action or induced polarization mentioned above, which depends upon the chemical energies necessary to allow the ions to give up or receive electrons from the metallic surface, increases with the time that a d. c. current is allowed to flow through the rock; i. e. as ions pile up against the metallic interface the resistance to current flow increases. Eventually, there is enough polarization in the form of excess ions at the interfaces, to appreciably reduce the amount of current flow through the metallic particle. This polarization takes place at each of the infinite number of solution-metal interfaces in a mineralized rock.

When the d. c. voltage used to create this d. c. current flow is cut off, the Coulomb forces between the charged ions forming the polarization cause them to return to their normal position. This movement of charge creates a small current flow which can be measured on the surface of the ground as a decaying potential difference.

From an alternate viewpoint it can be seen that if the direction of the current through the system is reversed repeatedly before the polarization occurs, the effective resistivity of the system as a whole will change as the frequency of the switching is changed. This is a consequence of the fact that the amount of current flowing through each metallic interface depends upon the length of time that current has been passing through it in one direction.

The values of the per cent frequency effect or F. E. are a measurement of the polarization in the rock mass. However, since the measurement of the degree of polarization is related to the apparent resistivity of the rock mass it is found that the metal factor values or M. F. are the most useful values in determining the amount of polarization present in the rock mass. The MF values are obtained by normalizing the F. E. values for varying resistivities.

The induced polarization measurement is perhaps the most powerful geophysical method for the direct detection of metallic sulphide mineralization, even when this mineralization is of very low concentration. The lower limit of volume per cent sulphide necessary to produce a recognizable IP anomaly will vary with the geometry and geologic environment of the source, and the method of executing the survey. However, sulphide mineralization of less than one per cent by volume has been detected by the IP method under proper geological conditions.

The greatest application of the IP method has been in the search for disseminated metallic sulphides of less than 20% by volume. However, it has also been used successfully in the search for massive sulphides in situations where, due to source geometry, depth of source, or low resistivity of surface layer, the EM method can not be successfully applied. The ability to differentiate ionic conductors, such as water filled shear zones, makes the IP method a useful tool in checking EM

anomalies which are suspected of being due to these causes.

In normal field applications the IP method does not differentiate between the economically important metallic minerals such as chalcopyrite, chalcocite, molybdenite, galena, etc., and the other metallic minerals such as pyrite. The induced polarization effect is due to the total of all electronic conducting minerals in the rock mass. Other electronic conducting materials which can produce an IP response are magnetite, pyrolusite, graphite, and some forms of hematite.

In the field procedure, measurements on the surface are made in a way that allows the effects of lateral changes in the properties of the ground to be separated from the effects of vertical changes in the properties. Current is applied to the ground at two points in distance (X) apart. The potentials are measured at two other points (X) feet apart, in line with the current electrodes is an integer number (n) times the basic distance (X).

The measurements are made along a surveyed line, with a constant distance (nX) between the nearest current and potential electrodes. In most surveys, several traverses are made with various values of (n); i. e. (n) = 1, 2, 3, 4, etc. The kind of survey required (detailed or reconnaissance) decides the number of values of (n) used.

In plotting the results, the values of the apparent resistivity, apparent per cent frequency effect, and the apparent metal factor

measured for each set of electrode positions are plotted at the intersection of grid lines, one from the center point of the current electrodes and the other from the center point of the potential electrodes. (See Figure A.) The resistivity values are plotted above the line as a mirror image of the metal factor values below. On a second line, below the metal factor values, are plotted the values of the per cent frequency effect. In some cases the values of per cent frequency effect are plotted as superscripts of the metal factor value. In this second case the frequency effect values are not contoured. The lateral displacement of a given value is determined by the location along the survey line of the center point between the current and potential electrodes. The distance of the value from the line is determined by the distance (nX) between the current and potential electrodes when the measurement was made.

The separation between sender and receiver electrodes is only one factor which determines the depth to which the ground is being sampled in any particular measurement. The plots then, when contoured, are not section maps of the electrical properties of the ground under the survey line. The interpretation of the results from any given survey must be carried out using the combined experience gained from field results, model study results and theoretical investigations. The position of the electrodes when anomalous values are measured is important in the interpretation.

In the field procedure, the interval over which the potential differences are measured is the same as the interval over which the electrodes are moved after a series of potential readings has been made. One of the advantages of the induced polarization method is that the same equipment can be used for both detailed and reconnaissance surveys merely by changing the distance (X) over which the electrodes are moved each time. In the past, intervals have been used ranging from 25 feet to 2000 feet for (X). In each case, the decision as to the distance (X) and the values of (n) to be used is largely determined by the expected size of the mineral deposit being sought, the size of the expected anomaly and the speed with which it is desired to progress.

The diagram in Figure A demonstrates the method used in plotting the results. Each value of the apparent resistivity, apparent metal factor, and apparent per cent frequency effect is plotted and identified by the position of the four electrodes when the measurement was made. It can be seen that the values measured for the larger values of (n) are plotted farther from the line indicating that the thickness of the layer of the earth that is being tested is greater than for the smaller values of (n); i. e. the depth of the measurement is increased. When the F. E. values are plotted as superscripts to the MF values the third section of data values is not presented and the F. E. values are not contoured.

The actual data plots included with the report are prepared utilizing an IBM 360/75 Computer and a Calcomp 770/763 Incremental Plotting System. The data values are calculated, plotted, and contoured according to a programme developed by McPhar Geophysics. Certain symbols have been incorporated into the programme to explain various situations in recording the data in the field.

The IP measurement is basically obtained by measuring the difference in potential or voltage (ΔV) obtained at two operating frequencies. The voltage is the product of the current through the ground and the apparent resistivity of the ground. Therefore in field situations where the current is very low due to poor electrode contact, or the apparent resistivity is very low, or a combination of the two effects; the value of (ΔV) the change in potential will be too small to be measurable. The symbol "TL" on the data plots indicates this situation.

In some situations spurious noise, either man made or natural, will render it impossible to obtain a reading. The symbol "N" on the data plots indicates a station at which it is too noisy to record a reading. If a reading can be obtained, but for reasons of noise there is some doubt as to its accuracy, the reading is bracketed in the data plot ().

In certain situations negative values of Apparent Frequency Effect are recorded. This may be due to the geologic environment or spurious electrical effects. The actual negative frequency effect value recorded is indicated on the data plot, however the symbol "NEG" is

indicated for the corresponding value of Apparent Metal Factor. In contouring negative values the contour lines are indicated to the nearest positive value in the immediate vicinity of the negative value.

The symbol "NR" indicates that for some reason the operator did not attempt to record a reading although normal survey procedures would suggest that one was required. This may be due to inaccessible topography or other similar reasons. Any symbol other than those discussed above is unique to a particular situation and is described within the body of the report.

METHOD USED IN PLOTTING DIPOLE-DIPOLE INDUCED POLARIZATION AND RESISTIVITY RESULTS

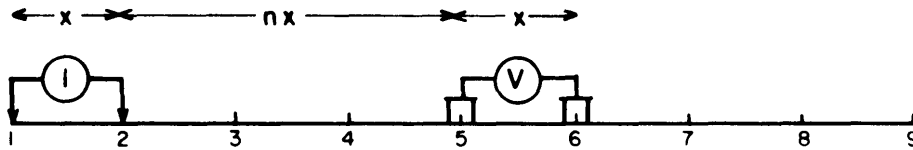

Stations on line

x = Electrode spread length
 n = Electrode separation

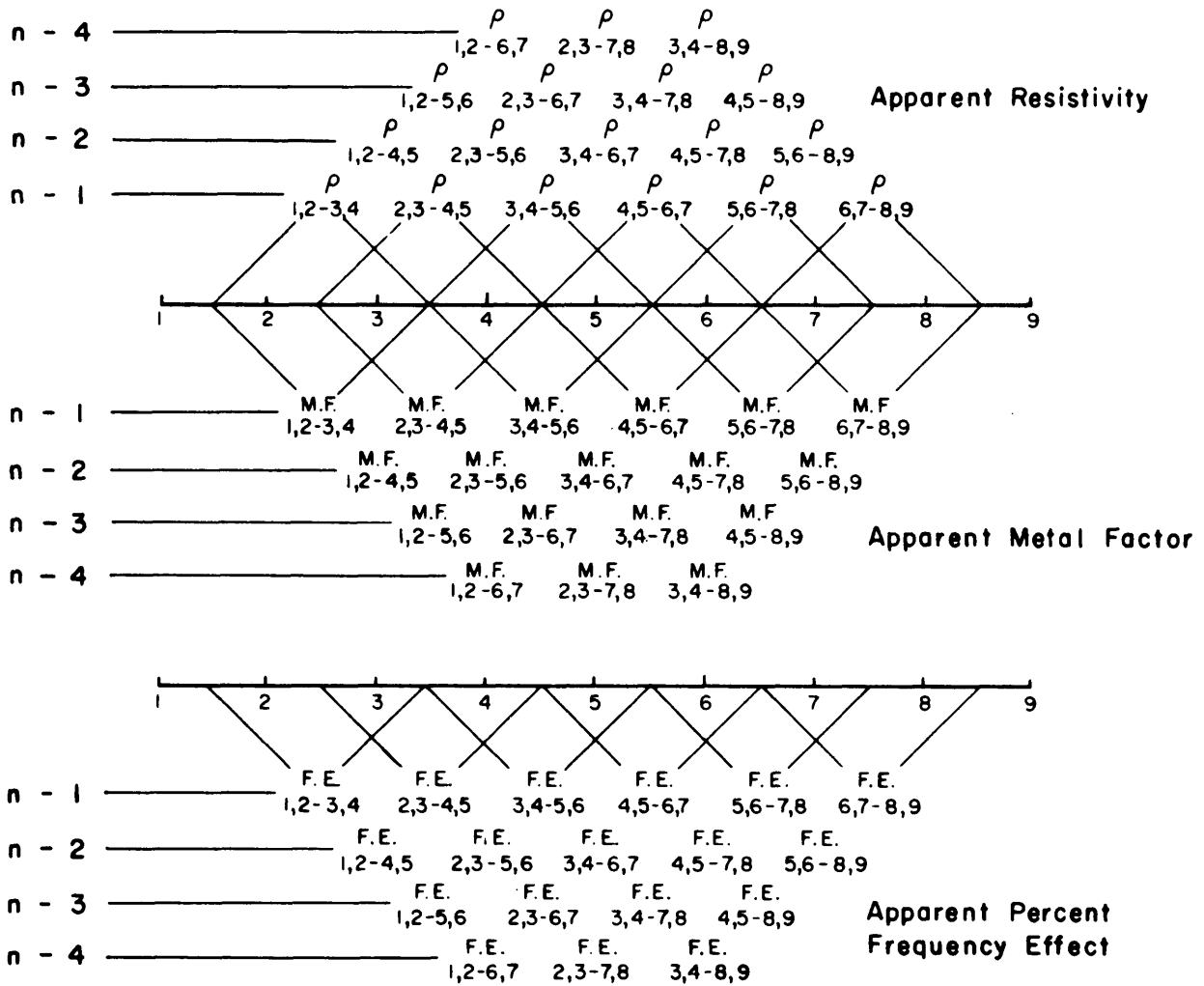

Fig. A

Mc PHAR GEOPHYSICS LIMITED

MEMORANDUM ON THE
INDUCED POLARIZATION
AND RESISTIVITY RESULTS

ON THE
NEW SHEEDY CREEK PROPERTY,

ANOMALY 7,

BULKLEY VALLEY, B.C.

FOR

SEARCHLIGHT EXPLORATION CORPORATION

The induced polarization and resistivity survey was carried out to investigate an airborne anomaly. It is understood that this area has heavy overburden cover. As a consequence no detailed geological information is available.

The survey consisted of four east-west lines, 800 feet apart with 500' electrode separations using frequencies of 0.3 and 5.0 cps.

In general, the resistivities over the survey area were very low, accompanied, with a few exceptions, by minimal or no increase in frequency effects. Thus, what appear to be anomalously high metal factor readings may simply be low resistivity responses.

Line 8N

A weak relatively shallow anomaly extends from 20E to 30E. A second weak anomaly, incomplete at the eastern end of the line, increases in

magnitude with depth.

Line 0

A weak incomplete anomaly is indicated from 20W to the west. A moderate anomaly from 5E to 10E is narrow and shallow relative to the electrode interval. A narrow, weak anomaly was located from 21E to 25E. A fourth anomaly, incomplete at the eastern end of the line, extends from 40E to 50E and is shallow and weak.

Line 8S

A broad, weak zone was located from 10W to 15E, with one section of greater magnitude from 10E to 14E. A narrow weak zone extends from 25E to 30E.

Line 24S

No anomalies were located.

Two potential zones were outlined by the survey. The first zone could be represented by the following anomalies: Line 8N - 20E to 30E; Line 0 - 21E to 25E; Line 8S - 25E to 30E.

The second zone was apparent on only two lines - Line 8N from 40E to 50E and Line 0 from 40E to 50E. Line 8S did not extend far enough east to locate the zone, if it were present.

It would be necessary to survey intermediate parallel lines to check the continuity of a single source for each zone.

A geochemical survey might be of value in this area, since the source of most of the anomalies appears to be at some depth. A possible location for a drill hole, if drilling were considered, would be on Line 0 to test

the anomaly beneath 7E at a vertical depth of 250'.

McPHAR GEOPHYSICS LIMITED

Marion A. Goudie

Marion A. Goudie,
Geologist.

Dated: February 2, 1971

SEARCHLIGHT EXPLORATION CORPORATION

NEW SHEEDY CREEK, BULKLEY VALLEY AREA

OMINECA M.O., B.C.

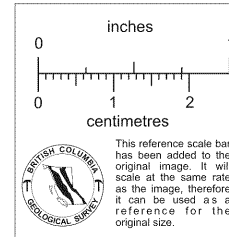

LINE NO. - 0

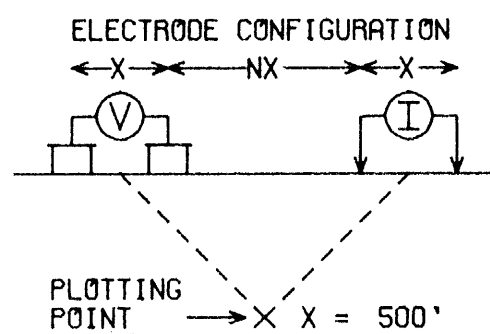

SURFACE PROJECTION OF ANOMALOUS ZONES

DEFINITE
 PROBABLE
 POSSIBLE

FREQUENCIES: 0.31-5.0 HZ

DATE SURVEYED: OCT 1970

APPROVED:

DATE: Feb 7 1971

NOTE: CONTOURS AT LOGARITHMIC INTERVALS 1.-1.5-2.-3.-5.-7.5-10

McPHAR GEOPHYSICS

INDUCED POLARIZATION AND RESISTIVITY SURVEY

NOTE: THIS PLOT WAS PRODUCED WITH AN IBM 360/65 COMPUTER AND A CALCOMP PLOTTER

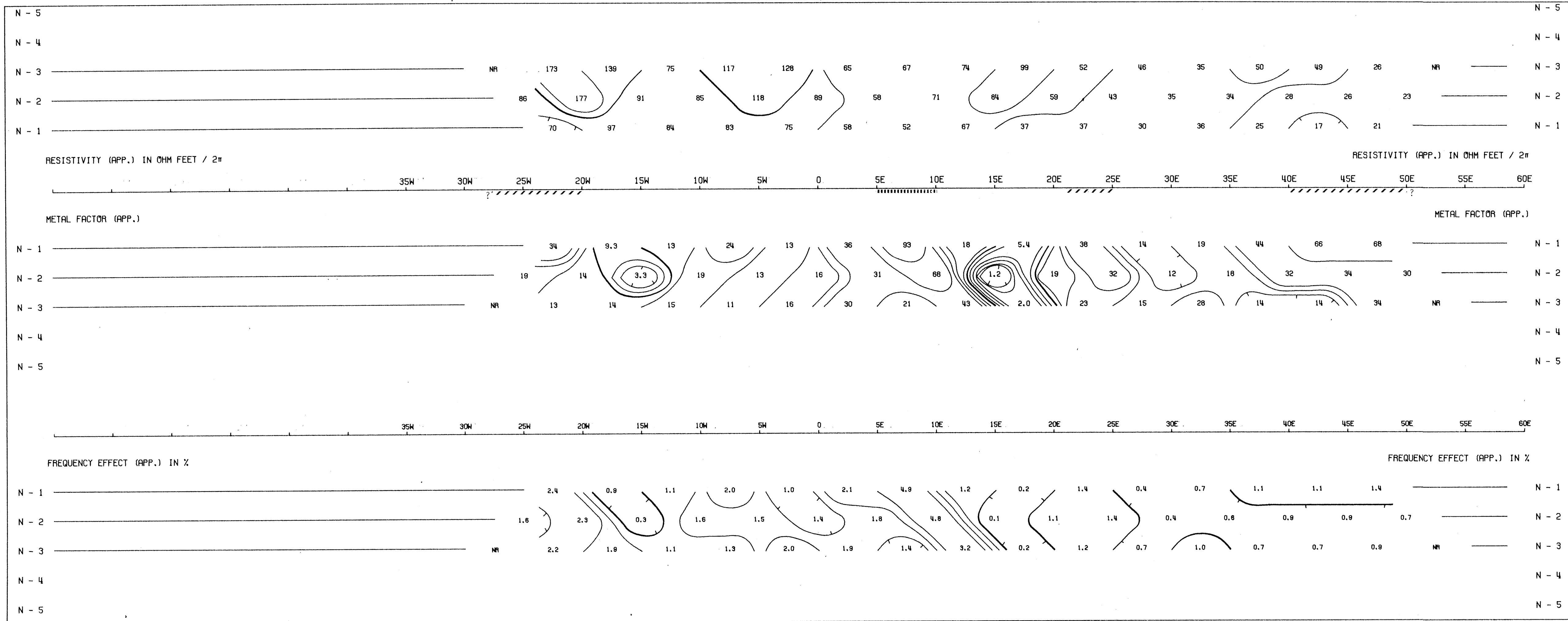

SEARCHLIGHT EXPLORATION CORPORATION

NEW SHEEDY CREEK, BULKLEY VALLEY AREA
OMINECA M.D., B.C.

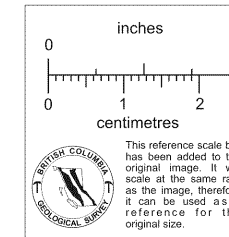

LINE NO.- 8S

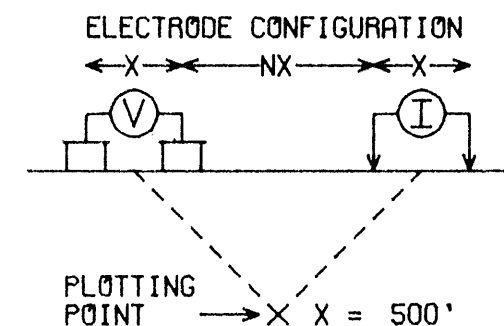

SURFACE PROJECTION OF ANOMALOUS ZONES

DEFINITE **—————**
PROBABLE **|||||**
POSSIBLE **////**

FREQUENCIES: 0.31-5.0 HZ

DATE SURVEYED: NOV 1970

APPROVED: _____

DATE: _____

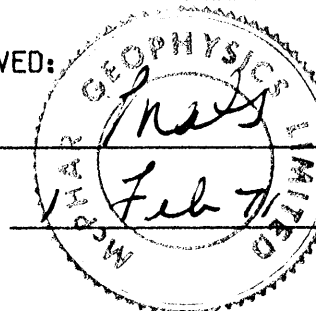

NOTE: CONTOURS AT LOGARITHMIC INTERVALS
1.-1.5-2.-3.-5.-7.5-10

McPHAR GEOPHYSICS

INDUCED POLARIZATION AND RESISTIVITY SURVEY

NOTE: THIS PLOT WAS PRODUCED WITH AN IBM 360/65 COMPUTER AND A CALCOMP PLOTTER

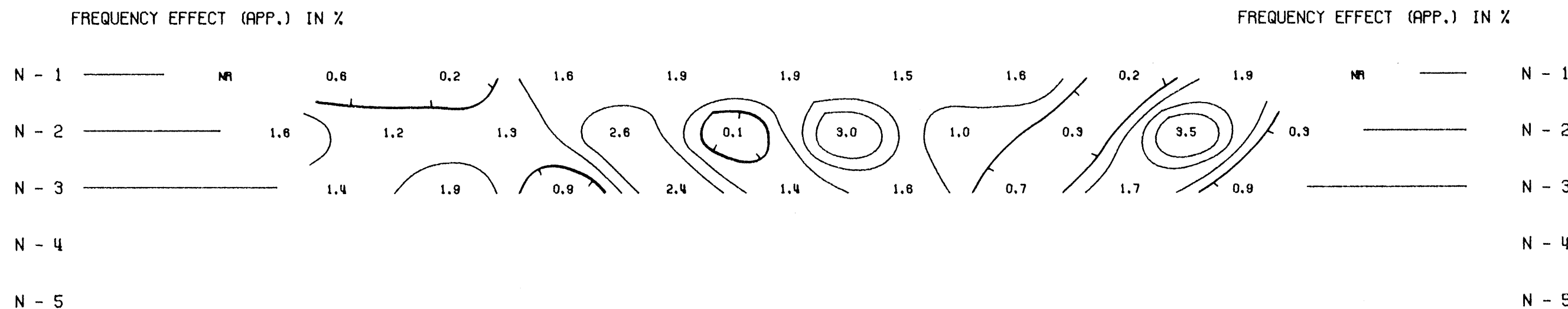
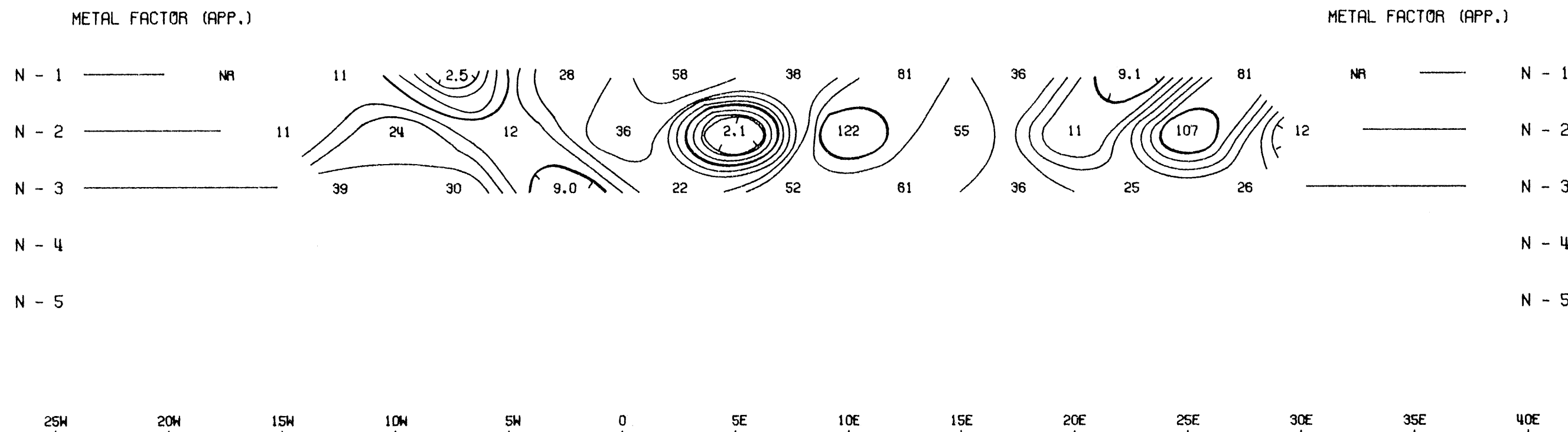
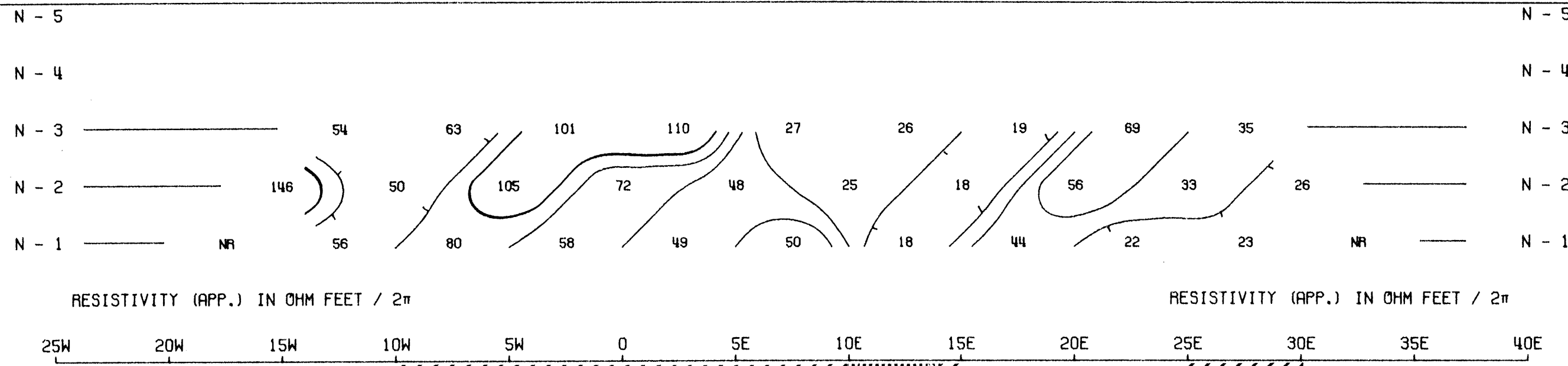

SEARCHLIGHT EXPLORATION CORPORATION

NEW SHEEDY CREEK, BULKLEY VALLEY AREA
OMINECA M.D., B.C.

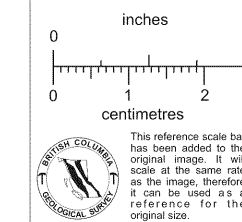

LINE NO. - 245

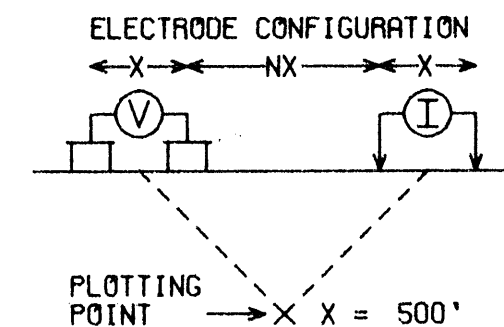

SURFACE PROJECTION OF ANOMALOUS ZONES

DEFINITE **—————**
PROBABLE **|||||**
POSSIBLE **////**

FREQUENCIES: 0.31-5.0 HZ

DATE SURVEYED: NOV 1970

APPROVED: _____

DATE: _____

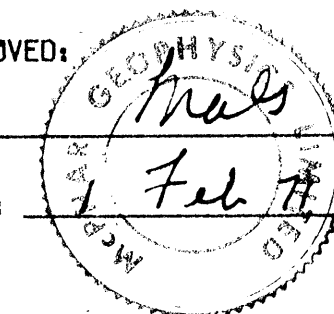

NOTE: CONTOURS AT LOGARITHMIC INTERVALS
1.-1.5-2.-3.-5.-7.5-10

McPHAR GEOPHYSICS

INDUCED POLARIZATION AND RESISTIVITY SURVEY

NOTE: THIS PLOT WAS PRODUCED WITH AN IBM 360/65 COMPUTER AND A CALCOMP PLOTTER

