



REPORT ON 92.I/5
INDUCED POLARIZATION
AND RESISTIVITY SURVEY
ON THE **811108**
SKUHUN CREEK CLAIMS
HIGHLAND VALLEY AREA,
KAMLOOPS M.D., B.C.
FOR
CYPRUS EXPLORATION CORPORATION LTD.

McPHAR GEOPHYSICS LIMITED

REPORT ON 92 I/5
INDUCED POLARIZATION
AND RESISTIVITY SURVEY
ON THE **811108**
SKUHUN CREEK CLAIMS
HIGHLAND VALLEY AREA,
KAMLOOPS M.D., B.C.
FOR
CYPRUS EXPLORATION CORPORATION LTD.

BY

R. A. BELL, Ph.D.

DAVID K. FOUNTAIN, P. ENG.

NAME AND LOCATION OF PROPERTY:

SKUHUN CREEK CLAIMS, HIGHLAND VALLEY AREA,
KAMLOOPS MINING DIVISION, B.C. 50°N, 121°W - SE

DATE STARTED: December 1, 1969

DATE FINISHED: December 6, 1969

TABLE OF CONTENTS

<u>Part A:</u>	Notes on theory and field procedure	9 pages	
<u>Part B:</u>	Report	9 pages	<u>Page</u>
1.	Introduction		1
2.	Presentation of Results		2
3.	Discussion of Results		3
4.	Summary and Recommendations		5
5.	Assessment Details		6
6.	Statement of Cost		7
7.	Certificate (Robert A. Bell)		8
8.	Certificate (David Kirkman Fountain)		9
<u>Part C:</u>	Illustrations	6 pieces	
	Plan Map (in pocket)	Dwg. I. P. P. 2840	
	IP Data Plots	Dwgs. IP 5374-1 to -5	

McPHAR GEOPHYSICS

NOTES ON THE THEORY, METHOD OF FIELD OPERATION, AND PRESENTATION OF DATA FOR THE INDUCED POLARIZATION METHOD

Induced Polarization as a geophysical measurement refers to the blocking action or polarization of metallic or electronic conductors in a medium of ionic solution conduction.

This electro-chemical phenomenon occurs wherever electrical current is passed through an area which contains metallic minerals such as base metal sulphides. Normally, when current is passed through the ground, as in resistivity measurements, all of the conduction takes place through ions present in the water content of the rock, or soil, i. e. by ionic conduction. This is because almost all minerals have a much higher specific resistivity than ground water. The group of minerals commonly described as "metallic", however, have specific resistivities much lower than ground waters. The induced polarization effect takes place at those interfaces where the mode of conduction changes from ionic in the solutions filling the interstices of the rock to electronic in the metallic minerals present

in the rock.

The blocking action or induced polarization mentioned above, which depends upon the chemical energies necessary to allow the ions to give up or receive electrons from the metallic surface, increases with the time that a d. c. current is allowed to flow through the rock; i. e. as ions pile up against the metallic interface the resistance to current flow increases. Eventually, there is enough polarization in the form of excess ions at the interfaces, to appreciably reduce the amount of current flow through the metallic particle. This polarization takes place at each of the infinite number of solution-metal interfaces in a mineralized rock.

When the d. c. voltage used to create this d. c. current flow is cut off, the Coulomb forces between the charged ions forming the polarization cause them to return to their normal position. This movement of charge creates a small current flow which can be measured on the surface of the ground as a decaying potential difference.

From an alternate viewpoint it can be seen that if the direction of the current through the system is reversed repeatedly before the polarization occurs, the effective resistivity of the system as a whole will change as the frequency of the switching is changed. This is a consequence of the fact that the amount of current flowing through each metallic interface depends upon the length of time that current has been passing through it in one direction.

The values of the per cent frequency effect or F. E. are a measurement of the polarization in the rock mass. However, since the measurement of the degree of polarization is related to the apparent resistivity of the rock mass it is found that the metal factor values or M. F. are the most useful values in determining the amount of polarization present in the rock mass. The MF values are obtained by normalizing the F. E. values for varying resistivities.

The induced polarization measurement is perhaps the most powerful geophysical method for the direct detection of metallic sulphide mineralization, even when this mineralization is of very low concentration. The lower limit of volume per cent sulphide necessary to produce a recognizable IP anomaly will vary with the geometry and geologic environment of the source, and the method of executing the survey. However, sulphide mineralization of less than one per cent by volume has been detected by the IP method under proper geological conditions.

The greatest application of the IP method has been in the search for disseminated metallic sulphides of less than 20% by volume. However, it has also been used successfully in the search for massive sulphides in situations where, due to source geometry, depth of source, or low resistivity of surface layer, the EM method can not be successfully applied. The ability to differentiate ionic conductors, such as water filled shear zones, makes the IP method a useful tool in checking EM

anomalies which are suspected of being due to these causes.

In normal field applications the IP method does not differentiate between the economically important metallic minerals such as chalcopyrite, chalcocite, molybdenite, galena, etc., and the other metallic minerals such as pyrite. The induced polarization effect is due to the total of all electronic conducting minerals in the rock mass. Other electronic conducting materials which can produce an IP response are magnetite, pyrolusite, graphite, and some forms of hematite.

In the field procedure, measurements on the surface are made in a way that allows the effects of lateral changes in the properties of the ground to be separated from the effects of vertical changes in the properties. Current is applied to the ground at two points in distance (X) apart. The potentials are measured at two other points (X) feet apart, in line with the current electrodes is an integer number (n) times the basic distance (X).

The measurements are made along a surveyed line, with a constant distance (nX) between the nearest current and potential electrodes. In most surveys, several traverses are made with various values of (n); i. e. (n) = 1, 2, 3, 4, etc. The kind of survey required (detailed or reconnaissance) decides the number of values of (n) used.

In plotting the results, the values of the apparent resistivity, apparent per cent frequency effect, and the apparent metal factor

measured for each set of electrode positions are plotted at the intersection of grid lines, one from the center point of the current electrodes and the other from the center point of the potential electrodes. (See Figure A.) The resistivity values are plotted above the line as a mirror image of the metal factor values below. On a second line, below the metal factor values, are plotted the values of the per cent frequency effect. In some cases the values of per cent frequency effect are plotted as superscripts of the metal factor value. In this second case the frequency effect values are not contoured. The lateral displacement of a given value is determined by the location along the survey line of the center point between the current and potential electrodes. The distance of the value from the line is determined by the distance (nX) between the current and potential electrodes when the measurement was made.

The separation between sender and receiver electrodes is only one factor which determines the depth to which the ground is being sampled in any particular measurement. The plots then, when contoured, are not section maps of the electrical properties of the ground under the survey line. The interpretation of the results from any given survey must be carried out using the combined experience gained from field results, model study results and theoretical investigations. The position of the electrodes when anomalous values are measured is important in the interpretation.

In the field procedure, the interval over which the potential differences are measured is the same as the interval over which the electrodes are moved after a series of potential readings has been made. One of the advantages of the induced polarization method is that the same equipment can be used for both detailed and reconnaissance surveys merely by changing the distance (X) over which the electrodes are moved each time. In the past, intervals have been used ranging from 25 feet to 2000 feet for (X). In each case, the decision as to the distance (X) and the values of (n) to be used is largely determined by the expected size of the mineral deposit being sought, the size of the expected anomaly and the speed with which it is desired to progress.

The diagram in Figure A demonstrates the method used in plotting the results. Each value of the apparent resistivity, apparent metal factor, and apparent per cent frequency effect is plotted and identified by the position of the four electrodes when the measurement was made. It can be seen that the values measured for the larger values of (n) are plotted farther from the line indicating that the thickness of the layer of the earth that is being tested is greater than for the smaller values of (n); i. e. the depth of the measurement is increased. When the F. E. values are plotted as superscripts to the MF values the third section of data values is not presented and the F. E. values are not contoured.

The actual data plots included with the report are prepared utilizing an IBM 360/75 Computer and a Calcomp 770/763 Incremental Plotting System. The data values are calculated, plotted, and contoured according to a programme developed by McPhar Geophysics. Certain symbols have been incorporated into the programme to explain various situations in recording the data in the field.

The IP measurement is basically obtained by measuring the difference in potential or voltage (ΔV) obtained at two operating frequencies. The voltage is the product of the current through the ground and the apparent resistivity of the ground. Therefore in field situations where the current is very low due to poor electrode contact, or the apparent resistivity is very low, or a combination of the two effects; the value of (ΔV) the change in potential will be too small to be measurable. The symbol "TL" on the data plots indicates this situation.

In some situations spurious noise, either man made or natural, will render it impossible to obtain a reading. The symbol "N" on the data plots indicates a station at which it is too noisy to record a reading. If a reading can be obtained, but for reasons of noise there is some doubt as to its accuracy, the reading is bracketed in the data plot ().

In certain situations negative values of Apparent Frequency Effect are recorded. This may be due to the geologic environment or spurious electrical effects. The actual negative frequency effect value recorded is indicated on the data plot, however the symbol "NEG" is

indicated for the corresponding value of Apparent Metal Factor. In contouring negative values the contour lines are indicated to the nearest positive value in the immediate vicinity of the negative value.

The symbol "NR" indicates that for some reason the operator did not attempt to record a reading although normal survey procedures would suggest that one was required. This may be due to inaccessible topography or other similar reasons. Any symbol other than those discussed above is unique to a particular situation and is described within the body of the report.

McPHAR GEOPHYSICS LIMITED

REPORT ON
INDUCED POLARIZATION
AND RESISTIVITY SURVEY
ON THE
SKUHUN CREEK CLAIMS
HIGHLAND VALLEY AREA,
KAMLOOPS M.D., B.C.
FOR
CYPRUS EXPLORATION CORPORATION LTD.

1. INTRODUCTION

At the request of Cyprus Exploration Corporation Limited we have carried out a brief induced polarization and resistivity survey of Area "B" on the Skuhun Creek claim group. The property is situated in the Highland Valley District of the Kamloops Mining Division, in the southeast quadrant of the one degree quadrilateral whose southeast corner is at 50° N latitude and 121° W longitude.

The claims are about mid-way between the Craigmont and Lornex properties, in the central part of the Guichon batholith. Previous work by the Company has located several soil samples with anomalous copper values and at least one copper showing. Electromagnetic and magnetometer surveys have also been carried out and the results of these surveys were supplied by Cyprus Exploration Corporation Limited. The present investigation was intended to test for the presence of any concentrations of metallic minerals and was performed during December, 1969

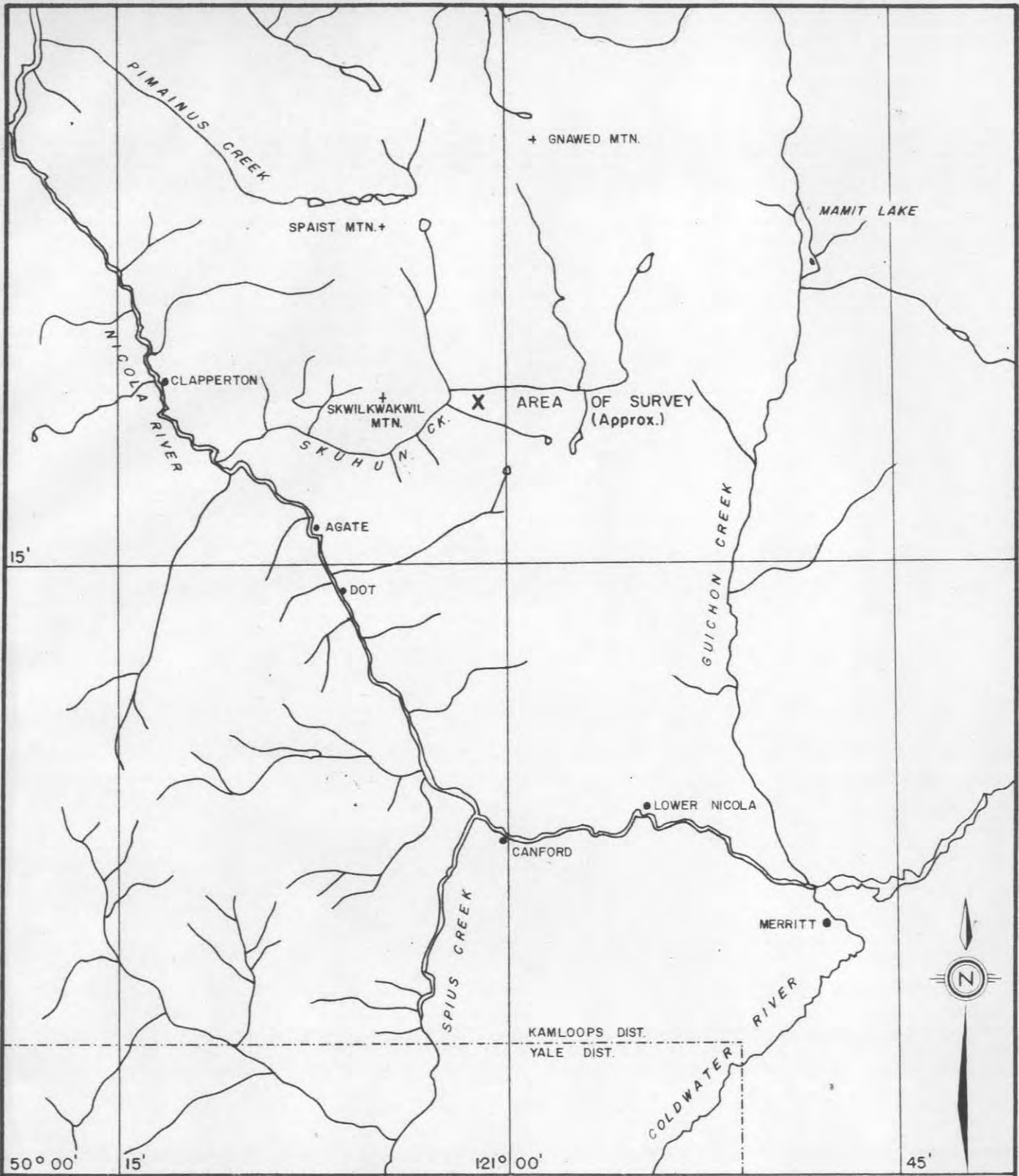

LOCATION MAP

CYPRUS EXPLORATION CORP. LTD.

AREA "B" SKUHUN CREEK CLAIMS, HIGHLAND VALLEY AREA, KAMLOOPS M.D., B.C.

SCALE

ONE INCH EQUALS FOUR MILES

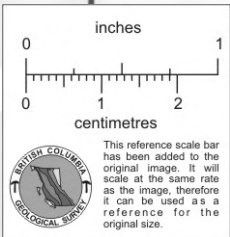

using a McPhar frequency domain IP system operating at 0.3 Hertz and 5.0 Hertz and utilizing a 200-foot dipole-dipole electrode array.

The survey was carried out on the following claims, all of which are within the Kamloops Mining Division:

KU 2, 4, 6, 10, 11, 12 and 14

All claims are assumed to be owned or held under option by Cyprus Exploration Corporation Limited.

2. PRESENTATION OF RESULTS

The induced polarization and resistivity results are shown on the following data plots in the manner described in the notes preceding this report.

Line 40E	200 foot spreads	Dwg. IP 5374-1
Line 44E	200 foot spreads	Dwg. IP 5374-2
Line 67E	200 foot spreads	Dwg. IP 5374-3
Line 71E	200 foot spreads	Dwg. IP 5374-4
Base Line 30N	200 foot spreads	Dwg. IP 5374-5

Enclosed with this report is Dwg. I. P. P. 2840, a plan map of the grid at a scale of 1" = 300'. The definite and possible induced polarization anomalies are indicated by solid and broken bars respectively on this plan map as well as the data plots. These bars represent the surface projection of the anomalous zones as interpreted from the location of the transmitter and receiver electrodes when the anomalous values were measured.

Since the induced polarization measurement is essentially an averaging process, as are all potential methods, it is frequently difficult

to exactly pinpoint the source of an anomaly. Certainly, no anomaly can be located with more accuracy than the spread length; i. e. when using 200' spreads the position of a narrow sulphide body can only be determined to lie between two stations 200' apart. In order to locate sources at some depth, larger spreads must be used, with a corresponding increase in the uncertainties of location. Therefore, while the centre of the indicated anomaly probably corresponds fairly well with source, the length of the indicated anomaly along the line should not be taken to represent the exact edges of the anomalous material.

The location of survey lines relative to the claim boundaries and the names and relative position of the claims indicated on the map and discussed in the report, are based on information supplied by the professional staff of Cyprus Exploration Corporation Limited.

3. DISCUSSION OF RESULTS

The geophysical survey results are characterized by moderately high resistivities and low background IP effects. No definite anomalies were found but there are weak effects on all of the traverses. However, these minor increases in the Apparent Metal Factors usually only occur on the $n = 1$ separation and are associated with resistivity lows. The lack of any significant increase in Apparent Frequency Effect suggests that they represent variations in the overburden cover.

Line 40E

On this line there is a slight increase in the Apparent Metal Factor values, and a corresponding decrease in the resistivities, from 26N to 30N.

This feature appears to correlate with an EM-16 zone and also the Able Prospect.

Line 44E

A possible shallow narrow source is indicated at 14N to 16N. The marked decrease in resistivity level south of 16N or 17N may indicate a change in rock type. No distinct anomaly was obtained over the Able Prospect at 25N to 30N or over the small copper showing reported near 35N.

Line 67E

Weak anomalous effects were measured from 28N to 30N and from 34N to 36N but these responses are too weak to be of prime interest.

Line 71E

The results on this line are essentially blank. Neither Line 67E, nor Line 71E, extends quite far enough to completely cross the northern EM zone.

Base Line 30N

The probable anomaly centred between 53E and 55E is the strongest feature located by the survey and is at best a very weak response. It appears to represent a narrow source, rather than a broad disseminated source, but still might warrant further work.

Three possible anomalies have been shown on the data plot, but again these are too weak to be of prime interest. The western anomaly, from 41E to 43E, apparently correlates with the Able Prospect.

4. SUMMARY AND RECOMMENDATIONS

Only weak anomalies were obtained from the IP survey on the Ku Claims. Most of these features appear to represent at best local areas of minor metallic mineralization. No indication was found either of widespread mineralization of the Brenda type, as illustrated in the accompanying appendix, or of narrow concentrated deposits. In view of the limited amount of surveying, a few additional reconnaissance traverses would be required for a more complete evaluation of the claims.

However, the fact that the above background values of MF occur for the most part on the $n = 1$ separation and are associated with lower resistivities suggests that these weak responses may be due to effects within the overburden cover.

McPHAR GEOPHYSICS LIMITED

Robert A. Bell.

Robert A. Bell,
Geologist

David K. Fountain
David K. Fountain, NP, Eng.
Geophysicist



Expiry Date: April 25, 1970

Dated: January 20, 1970

STATEMENT OF COST

Cyprus Exploration Corporation Limited
Skuhun Creek Claims, Highland Valley Area, B.C.

<u>Crew (2 men)</u>		
5 days Operating	@ \$240.00	1,200.00
1 day Travel	@ \$ 85.00	85.00

<u>Expenses</u>	
Accommodation	114.50
Meals	155.48
Vehicle Expenses	17.89
Telephone and Telegraph	<u>15.40</u>
	303.27

Plus 10%	<u>30.33</u>	333.60
----------	--------------	--------

<u>Extra Labour</u>		
William Murray 6 days	@ \$18.00	108.00
Maurice R. George 5 days	@ \$20.00	100.00
Darcy McLeod 5 days	@ \$20.00	<u>100.00</u>
		308.00

Plus 20%	<u>61.60</u>
----------	--------------

	<u>369.60</u>
TOTAL	<u>\$1,988.20</u>

McPHAR GEOPHYSICS LIMITED

Robert A. Bell.
Robert A. Bell,
Geologist.

Dated: January 20, 1970

CERTIFICATE

I, Robert Alan Bell, of the City of Toronto, Province of Ontario, do hereby certify that:

1. I am a geologist residing at 50 Hemford Crescent, Don Mills, (Toronto) Ontario.
2. I am a graduate of the University of Toronto in Physics and Geology with the degree of Bachelor of Arts (1949); and a graduate of the University of Wisconsin in Economic Geology with the degree of Ph.D. (1953).
3. I am a member of the Society of Economic Geologists and a fellow of the Geological Association of Canada.
4. I have been practising my profession for over fifteen years.
5. I have no direct or indirect interest, nor do I expect to receive any interest directly or indirectly, in the property or securities of Cyprus Exploration Corporation Ltd. or any affiliate.
6. The statements made in this report are based on a study of published geological literature and unpublished private reports.
7. Permission is granted to use in whole or in part for assessment and qualification requirements but not for advertising purposes.

Dated at Toronto

This 20th day of January 1970

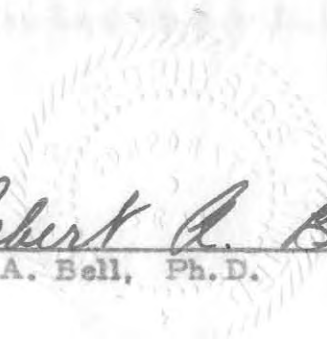
Robert A. Bell
Robert A. Bell, Ph.D.

CERTIFICATE

I, David Kirkman Fountain, of the City of Toronto, Province of Ontario, do certify that:

1. I am a geophysicist residing at 44 Highgate Road, Toronto 18, Ontario.
2. I am a graduate of the University of Toronto with a Bachelor of Applied Science Degree in Engineering Physics (Geophysics).
3. I am a member of the Society of Exploration Geophysicists, the European Association of Exploration Geophysicists and the Canadian Institute of Mining and Metallurgy.
4. I am a registered Professional Engineer in the Province of British Columbia and Ontario, and have been practising my profession for eight years.
5. The statements made in this report are based on a study of published geological literature and unpublished private reports.
6. Permission is granted to use in whole or in part for assessment and qualification requirements but not for advertising purposes.

Dated at Toronto

This 20th day of January 1970



David Kirkman Fountain
David Kirkman Fountain, B.A.Sc. P.Eng.
PROFESSIONAL
OF
PROVINCE
OF
BRITISH
COLUMBIA
ENGINEER

Expiry Date: April 25, 1970

Dwg. I. P. P. 2840

McPHAR GEOPHYSICS

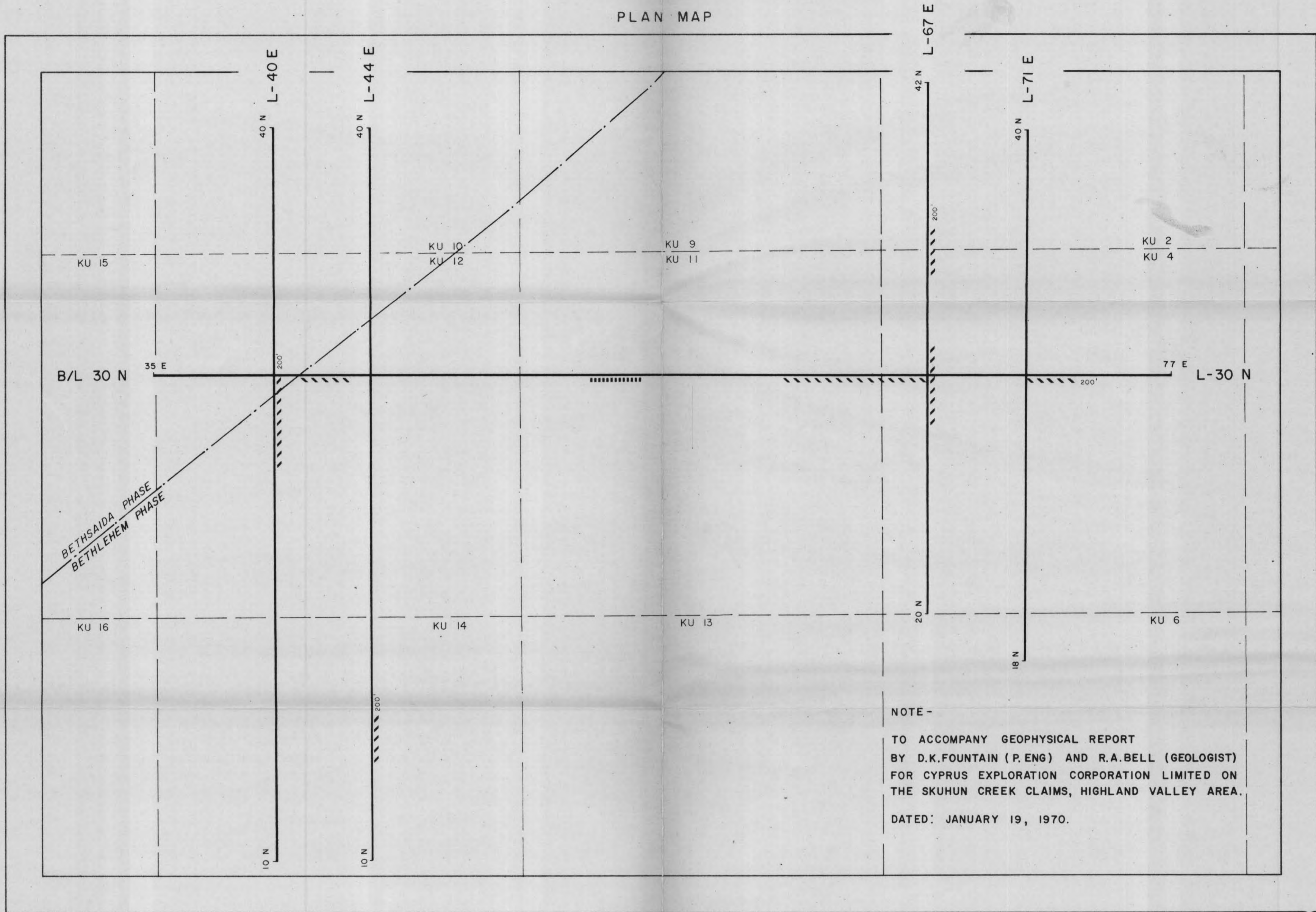

INDUCED POLARIZATION AND RESISTIVITY SURVEY
PLAN MAP



NOTE -
 TO ACCOMPANY GEOPHYSICAL REPORT
 BY D.K.FOUNTAIN (P.ENG) AND R.A.BELL (GEOLOGIST)
 FOR CYPRUS EXPLORATION CORPORATION LIMITED ON
 THE SKUHUN CREEK CLAIMS, HIGHLAND VALLEY AREA.
 DATED: JANUARY 19, 1970.



SURFACE PROJECTION
 OF ANOMALOUS ZONES

DEFINITE 
 PROBABLE 
 POSSIBLE 
 Numbers at the end of the
 anomalies indicate spread used.

CYPRUS EXPLORATION CORP. LTD.
 AREA "B" SKUHUN CREEK CLAIMS, HIGHLAND VALLEY AREA, KAMLOOPS M.D., B.C.
 SCALE
 ONE INCH EQUALS THREE HUNDRED FEET

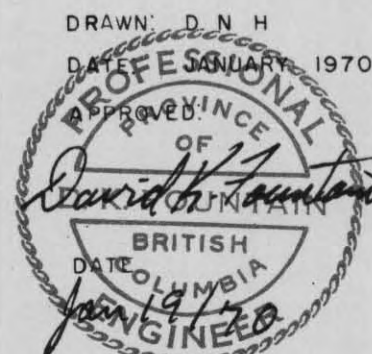
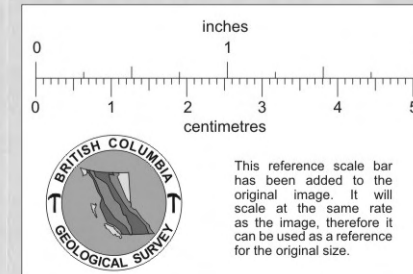

CYPRUS EXPLORATION CORPORATION LIMITED

AREA 'B' SKUHUN CREEK CLAIMS
HIGHLAND VALLEY AREA, KAMLOOPS M.D., B.C.

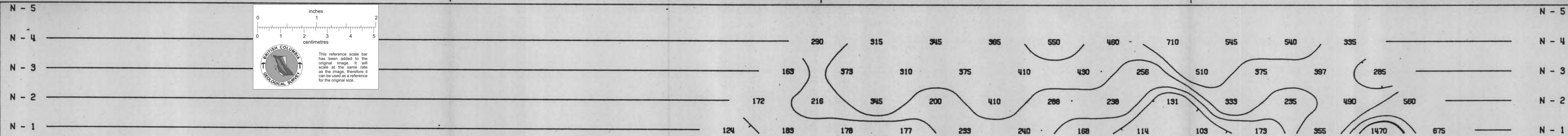
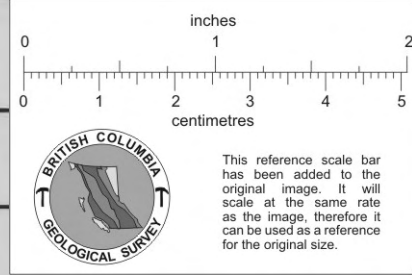

RESISTIVITY (APP.) IN OHM FEET / 2π

RESISTIVITY (APP.) IN OHM FEET / 2π

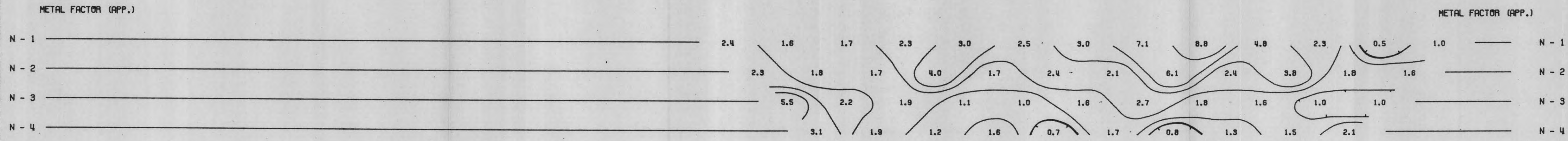
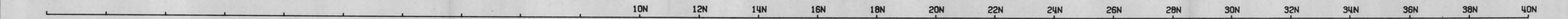

METAL FACTOR (APP.)

METAL FACTOR (APP.)



FREQUENCY EFFECT (APP.) IN %

FREQUENCY EFFECT (APP.) IN %

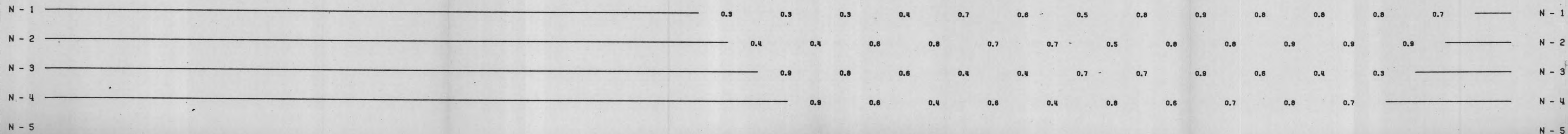

LINE NO. - 40E

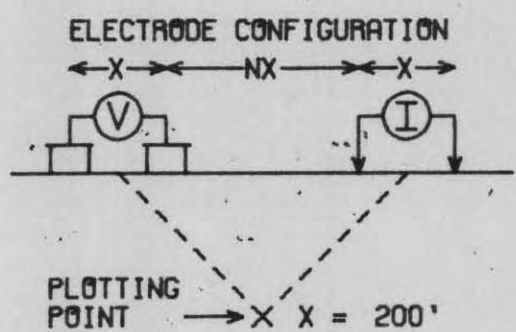

SURFACE PROJECTION OF ANOMALOUS ZONES
DEFINITE
PROBABLE
POSSIBLE

FREQUENCIES: 0.31-5.0 CPS DATE SURVEYED: DEC 1969

NOTE: CONTOURS AT LOGARITHMIC INTERVALS 1.-1.5-2.-3.-5.-7.5-10

APPROVED:
D.K. FOUNTAIN
PROFESSIONAL ENGINEER
DATE: Jan 19 1970
Expiry Date: April 25, 1970

McPHAR GEOPHYSICS

INDUCED POLARIZATION AND RESISTIVITY SURVEY

NOTE: THIS PLOT WAS PRODUCED WITH AN IBM 360/75 COMPUTER AND A CALCOMP PLOTTER

CYPRUS EXPLORATION CORPORATION LIMITED

AREA 'B' SKUHUN CREEK CLAIMS
HIGHLAND VALLEY AREA, KAMLOOPS M.D., B.C.

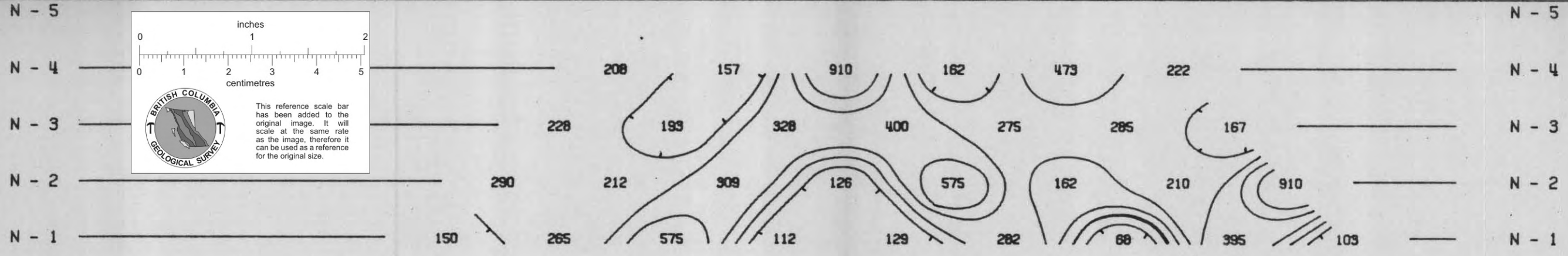
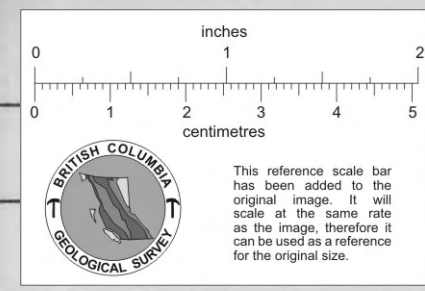

RESISTIVITY (APP.) IN OHM FEET / 2π

RESISTIVITY (APP.) IN OHM FEET / 2π

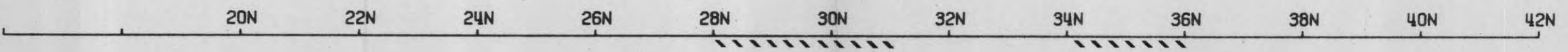

METAL FACTOR (APP.)

METAL FACTOR (APP.)

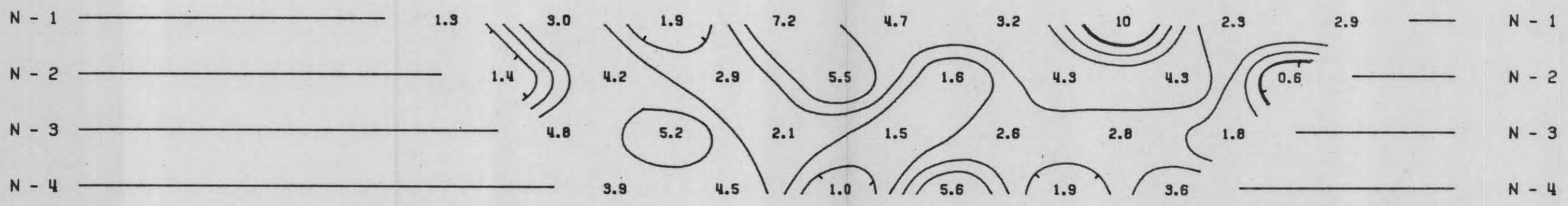

FREQUENCY EFFECT (APP.) IN %

FREQUENCY EFFECT (APP.) IN %

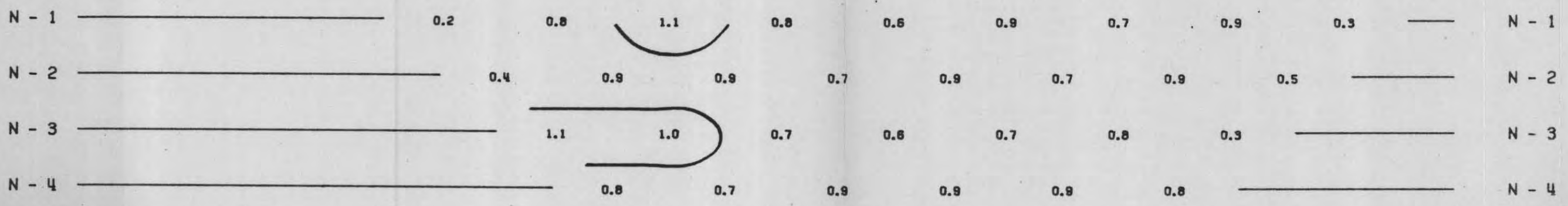

LINE NO. - 67E

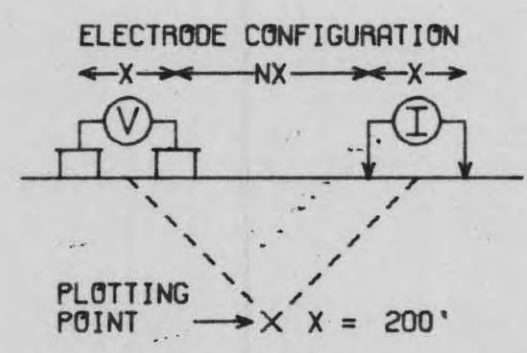

SURFACE PROJECTION OF ANOMALOUS ZONES

- DEFINITE
- PROBABLE
- POSSIBLE

FREQUENCIES: 0.31-5.0 CPS

DATE SURVEYED: DEC 1969

APPROVED: *[Signature]*
DATE: *[Signature]*

NOTE: CONTOURS AT LOGARITHMIC INTERVALS 1.-1.5-2.-3.-5.-7.5-10

Exp. Date: April 25, 1970

McPHAR GEOPHYSICS

INDUCED POLARIZATION AND RESISTIVITY SURVEY

NOTE: THIS PLOT WAS PRODUCED WITH AN IBM 360/75 COMPUTER AND A CALCOMP PLOTTER

CYPRUS EXPLORATION CORPORATION LIMITED

AREA 'B' SKUHUN CREEK CLAIMS
HIGHLAND VALLEY AREA, KAMLOOPS M.D., B.C.

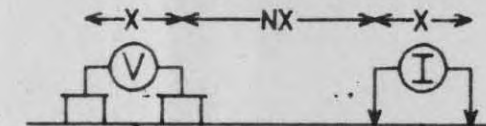

LINE NO. - 71E

ELECTRODE CONFIGURATION

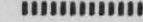

PLOTTING POINT → X X = 200'

SURFACE PROJECTION OF ANOMALOUS ZONES

DEFINITE 
PROBABLE 
POSSIBLE 

FREQUENCIES: 0.31-5.0 CPS

DATE SURVEYED: DEC 1969

APPROVED:

David H. Fountain
D. H. FOUNTAIN
COLUMBIA
ENGINEER

DATE:

Expiry Date: April 25, 1970

NOTE: CONTOURS AT LOGARITHMIC INTERVALS 1.-1.5-2.-3.-5.-7.5-10

McPHAR GEOPHYSICS

INDUCED POLARIZATION AND RESISTIVITY SURVEY

NOTE: THIS PLOT WAS PRODUCED WITH AN IBM 360/75 COMPUTER AND A CALCOMP PLOTTER

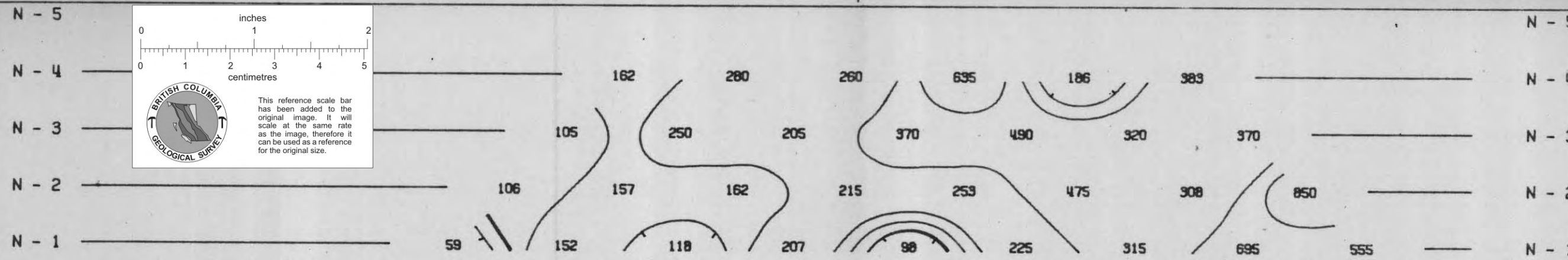

RESISTIVITY (APP.) IN OHM FEET / 2π

RESISTIVITY (APP.) IN OHM FEET / 2π

18N 20N 22N 24N 26N 28N 30N 32N 34N 36N 38N 40N

METAL FACTOR (APP.)

METAL FACTOR (APP.)

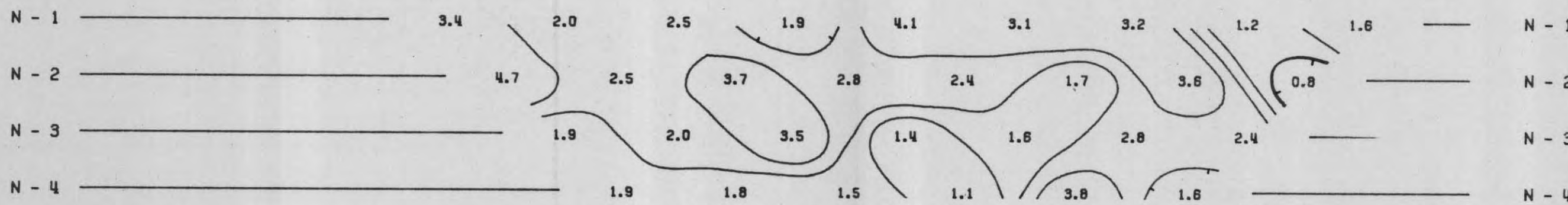

18N 20N 22N 24N 26N 28N 30N 32N 34N 36N 38N 40N

FREQUENCY EFFECT (APP.) IN %

FREQUENCY EFFECT (APP.) IN %

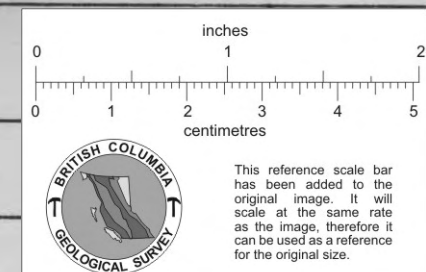
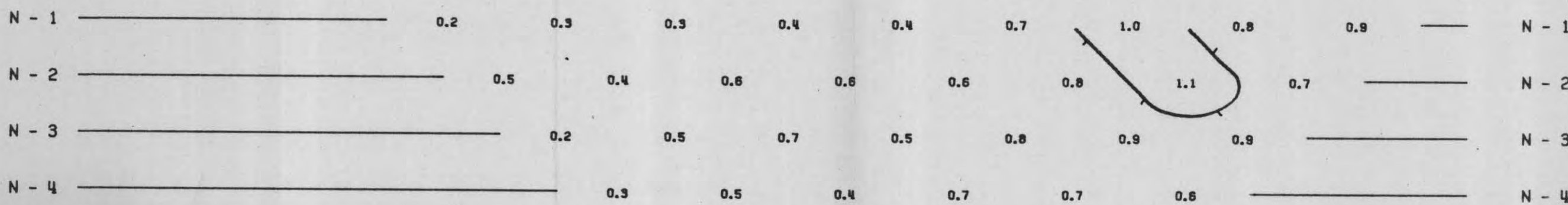

CYPRUS EXPLORATION CORPORATION LIMITED

AREA 'B' SKUHUN CREEK CLAIMS
HIGHLAND VALLEY AREA, KAMLOOPS M.D., B.C.

LINE NO. - B.L. 30N

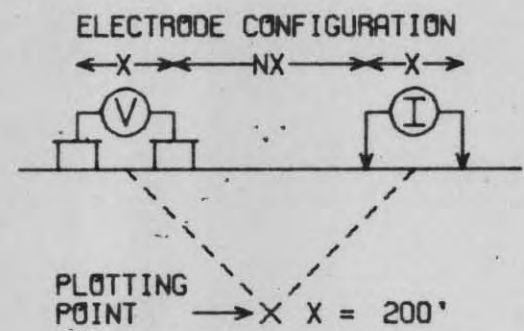

SURFACE PROJECTION OF ANOMALOUS ZONES
DEFINITE
PROBABLE
POSSIBLE

FREQUENCIES: 0.31-5.0 CPS

DATE SURVEYED: DEC 1969

APPROVED:

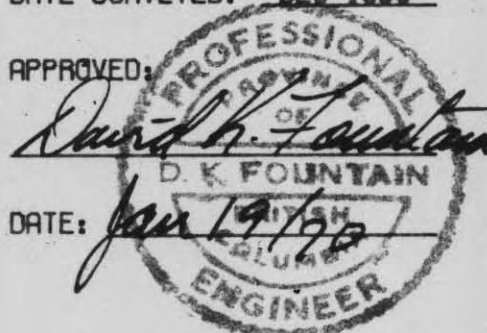

NOTE: CONTOURS AT LOGARITHMIC INTERVALS
1.-1.5-2.-3.-5.-7.5-10

McPHAR GEOPHYSICS

INDUCED POLARIZATION AND RESISTIVITY SURVEY

NOTE: THIS PLOT WAS PRODUCED WITH AN IBM 360/75 COMPUTER AND A CALCOMP PLOTTER

