

810594

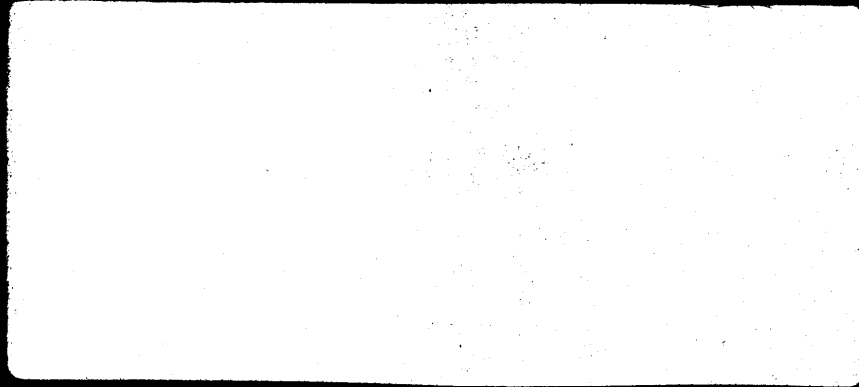

REPORT ON
INDUCED POLARIZATION
AND RESISTIVITY SURVEY
OF THE
BIG ONION PROPERTY
OMINECA MINING DIVISION, B.C.
FOR
BLUE ROCK MINING CORPORATION LTD.

93L-15

BY

ROBERT A. BELL, Ph.D.

AND

PHILIP G. HALLOF, Ph.D.

NAME AND LOCATION OF PROPERTY
BIG ONION PROPERTY, SMITHERS AREA
OMINECA MINING DIVISION, B.C. 54°N, 126°W - NW

DATE STARTED: JUNE 1, 1970

DATE FINISHED: AUGUST 31, 1970

TABLE OF CONTENTS

<u>Part A:</u>	Notes on theory and field procedure	9 pages	
<u>Part B:</u>	Report	14 pages	<u>Page</u>
1.	Introduction		1
2.	Presentation of Results		3
3.	Discussion of Results		5
4.	Summary and Recommendations		6
5.	Assessment Details		11
6.	Statement of Cost		12
7.	Certificate - Robert A. Bell		13
8.	Certificate - Philip G. Hallof		14
<u>Part C:</u>	Illustrations	21 pieces	
	Plan Map (in pocket)	Dwg. I. P. P. 4675	
	IP Data Plots	Dwg. IP 5563-1 to -20	

McPHAR GEOPHYSICS

NOTES ON THE THEORY, METHOD OF FIELD OPERATION, AND PRESENTATION OF DATA FOR THE INDUCED POLARIZATION METHOD

Induced Polarization as a geophysical measurement refers to the blocking action or polarization of metallic or electronic conductors in a medium of ionic solution conduction.

This electro-chemical phenomenon occurs wherever electrical current is passed through an area which contains metallic minerals such as base metal sulphides. Normally, when current is passed through the ground, as in resistivity measurements, all of the conduction takes place through ions present in the water content of the rock, or soil, i. e. by ionic conduction. This is because almost all minerals have a much higher specific resistivity than ground water. The group of minerals commonly described as "metallic", however, have specific resistivities much lower than ground waters. The induced polarization effect takes place at those interfaces where the mode of conduction changes from ionic in the solutions filling the interstices of the rock to electronic in the metallic minerals present

in the rock.

The blocking action or induced polarization mentioned above, which depends upon the chemical energies necessary to allow the ions to give up or receive electrons from the metallic surface, increases with the time that a d. c. current is allowed to flow through the rock; i. e. as ions pile up against the metallic interface the resistance to current flow increases. Eventually, there is enough polarization in the form of excess ions at the interfaces, to appreciably reduce the amount of current flow through the metallic particle. This polarization takes place at each of the infinite number of solution-metal interfaces in a mineralized rock.

When the d. c. voltage used to create this d. c. current flow is cut off, the Coulomb forces between the charged ions forming the polarization cause them to return to their normal position. This movement of charge creates a small current flow which can be measured on the surface of the ground as a decaying potential difference.

From an alternate viewpoint it can be seen that if the direction of the current through the system is reversed repeatedly before the polarization occurs, the effective resistivity of the system as a whole will change as the frequency of the switching is changed. This is a consequence of the fact that the amount of current flowing through each metallic interface depends upon the length of time that current has been passing through it in one direction.

The values of the per cent frequency effect or F. E. are a measurement of the polarization in the rock mass. However, since the measurement of the degree of polarization is related to the apparent resistivity of the rock mass it is found that the metal factor values or M. F. are the most useful values in determining the amount of polarization present in the rock mass. The MF values are obtained by normalizing the F. E. values for varying resistivities.

The induced polarization measurement is perhaps the most powerful geophysical method for the direct detection of metallic sulphide mineralization, even when this mineralization is of very low concentration. The lower limit of volume per cent sulphide necessary to produce a recognizable IP anomaly will vary with the geometry and geologic environment of the source, and the method of executing the survey. However, sulphide mineralization of less than one per cent by volume has been detected by the IP method under proper geological conditions.

The greatest application of the IP method has been in the search for disseminated metallic sulphides of less than 20% by volume. However, it has also been used successfully in the search for massive sulphides in situations where, due to source geometry, depth of source, or low resistivity of surface layer, the EM method can not be successfully applied. The ability to differentiate ionic conductors, such as water filled shear zones, makes the IP method a useful tool in checking EM

anomalies which are suspected of being due to these causes.

In normal field applications the IP method does not differentiate between the economically important metallic minerals such as chalcopyrite, chalcocite, molybdenite, galena, etc., and the other metallic minerals such as pyrite. The induced polarization effect is due to the total of all electronic conducting minerals in the rock mass. Other electronic conducting materials which can produce an IP response are magnetite, pyrolusite, graphite, and some forms of hematite.

In the field procedure, measurements on the surface are made in a way that allows the effects of lateral changes in the properties of the ground to be separated from the effects of vertical changes in the properties. Current is applied to the ground at two points in distance (X) apart. The potentials are measured at two other points (X) feet apart, in line with the current electrodes is an integer number (n) times the basic distance (X).

The measurements are made along a surveyed line, with a constant distance (nX) between the nearest current and potential electrodes. In most surveys, several traverses are made with various values of (n); i. e. (n) = 1, 2, 3, 4, etc. The kind of survey required (detailed or reconnaissance) decides the number of values of (n) used.

In plotting the results, the values of the apparent resistivity, apparent per cent frequency effect, and the apparent metal factor

measured for each set of electrode positions are plotted at the intersection of grid lines, one from the center point of the current electrodes and the other from the center point of the potential electrodes. (See Figure A.) The resistivity values are plotted above the line as a mirror image of the metal factor values below. On a second line, below the metal factor values, are plotted the values of the per cent frequency effect. In some cases the values of per cent frequency effect are plotted as superscripts of the metal factor value. In this second case the frequency effect values are not contoured. The lateral displacement of a given value is determined by the location along the survey line of the center point between the current and potential electrodes. The distance of the value from the line is determined by the distance (nX) between the current and potential electrodes when the measurement was made.

The separation between sender and receiver electrodes is only one factor which determines the depth to which the ground is being sampled in any particular measurement. The plots then, when contoured, are not section maps of the electrical properties of the ground under the survey line. The interpretation of the results from any given survey must be carried out using the combined experience gained from field results, model study results and theoretical investigations. The position of the electrodes when anomalous values are measured is important in the interpretation.

The actual data plots included with the report are prepared utilizing an IBM 360/75 Computer and a Calcomp 770/763 Incremental Plotting System. The data values are calculated, plotted, and contoured according to a programme developed by McPhar Geophysics. Certain symbols have been incorporated into the programme to explain various situations in recording the data in the field.

The IP measurement is basically obtained by measuring the difference in potential or voltage (ΔV) obtained at two operating frequencies. The voltage is the product of the current through the ground and the apparent resistivity of the ground. Therefore in field situations where the current is very low due to poor electrode contact, or the apparent resistivity is very low, or a combination of the two effects; the value of (ΔV) the change in potential will be too small to be measurable. The symbol "TL" on the data plots indicates this situation.

In some situations spurious noise, either man made or natural, will render it impossible to obtain a reading. The symbol "N" on the data plots indicates a station at which it is too noisy to record a reading. If a reading can be obtained, but for reasons of noise there is some doubt as to its accuracy, the reading is bracketed in the data plot ().

In certain situations negative values of Apparent Frequency Effect are recorded. This may be due to the geologic environment or spurious electrical effects. The actual negative frequency effect value recorded is indicated on the data plot, however the symbol "NEG" is

In the field procedure, the interval over which the potential differences are measured is the same as the interval over which the electrodes are moved after a series of potential readings has been made. One of the advantages of the induced polarization method is that the same equipment can be used for both detailed and reconnaissance surveys merely by changing the distance (X) over which the electrodes are moved each time. In the past, intervals have been used ranging from 25 feet to 2000 feet for (X). In each case, the decision as to the distance (X) and the values of (n) to be used is largely determined by the expected size of the mineral deposit being sought, the size of the expected anomaly and the speed with which it is desired to progress.

The diagram in Figure A demonstrates the method used in plotting the results. Each value of the apparent resistivity, apparent metal factor, and apparent per cent frequency effect is plotted and identified by the position of the four electrodes when the measurement was made. It can be seen that the values measured for the larger values of (n) are plotted farther from the line indicating that the thickness of the layer of the earth that is being tested is greater than for the smaller values of (n); i. e. the depth of the measurement is increased. When the F. E. values are plotted as superscripts to the MF values the third section of data values is not presented and the F. E. values are not contoured.

indicated for the corresponding value of Apparent Metal Factor. In contouring negative values the contour lines are indicated to the nearest positive value in the immediate vicinity of the negative value.

The symbol "NR" indicates that for some reason the operator did not attempt to record a reading although normal survey procedures would suggest that one was required. This may be due to inaccessible topography or other similar reasons. Any symbol other than those discussed above is unique to a particular situation and is described within the body of the report.

METHOD USED IN PLOTTING DIPOLE-DIPOLE INDUCED POLARIZATION AND RESISTIVITY RESULTS

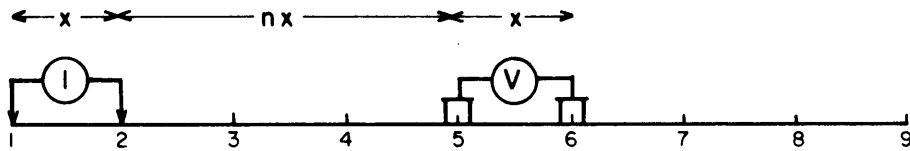

Stations on line

x = Electrode spread length
 n = Electrode separation

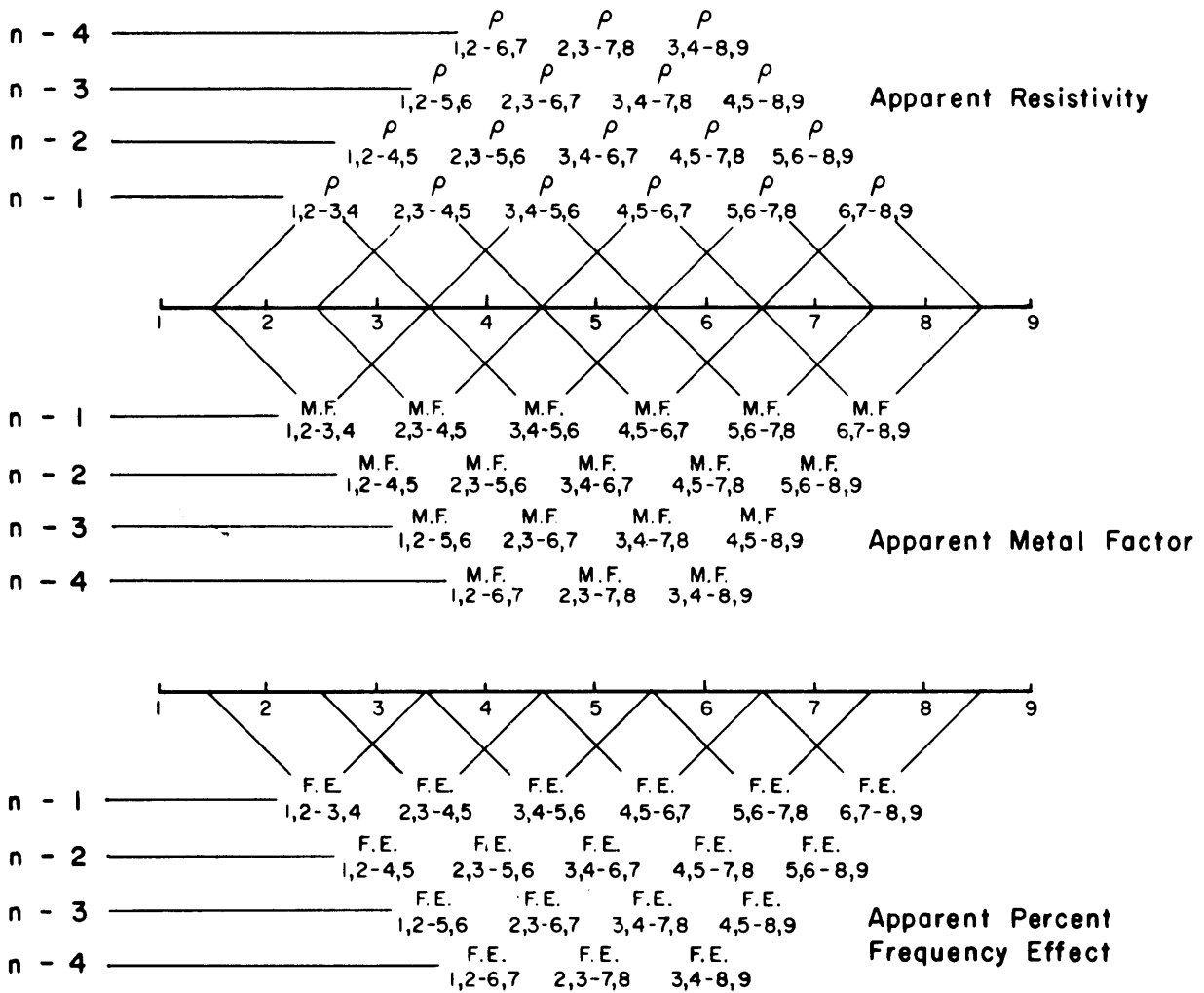

Fig. A

McPHAR GEOPHYSICS LIMITED

REPORT ON
INDUCED POLARIZATION
AND RESISTIVITY SURVEY
OF THE
BIG ONION PROPERTY
OMINECA MINING DIVISION, B.C.
FOR
BLUE ROCK MINING CORPORATION LTD.

1. INTRODUCTION

At the request of Blue Rock Mining Corporation Ltd., we have carried out a combined induced polarization and resistivity survey of the Big Onion Property in the Smithers Area of British Columbia. The property is situated in the Omineca Mining Division in the northwest quadrant of the one degree quadrilateral whose southeast corner is at 54°N latitude and 126°W longitude.

The property is accessible by road from Smithers and is of interest because of the presence of a mineralized intrusive. The IP survey was intended to outline areas of metallic mineralization that might be of economic interest, particularly any large, low grade deposits amenable to open pit mining. The survey was performed during July, August and September of 1970 using a McPhar frequency domain IP system operating at 0.3 and 5.0 Hz; a 500-foot dipole-dipole electrode array was employed for most of the work, with some detail using 200-foot dipoles.

The survey was carried out on the following claims, all within the
Omineca Mining Division and all assumed to be owned or optioned by Blue
Rock Mining Corporation Ltd.

<u>Jack</u>	-1	<u>Jack</u>	-24	<u>AL</u>	-5
	-1 FR		-25		-6
	-2		-26		-7
	-2 FR		-28		-8
	-3		-30		-9
	-3 FR		-31		-10
	-4		-32		-11
	-4 FR		-33		-12
	-5		-34		-13
	-5 FR		-35		-14
	-6		-36		
	-6 FR				
	-7				
	-7 FR				
	-8				
	-8 FR				
	-9				
	-9 FR				
	-10				
	-10 FR				
	-11				
	-11 FR				
	-12				
	-12 FR				
	-13				
	-13 FR				
	-14				
	-14 FR				
	-15				
	-15 FR				
	-16				
	-16 FR				
	-17				
	-18				
	-19				
	-20				
	-21				
	-22				
	-23				

<u>Jill</u>	-1	Ralph	-10	BA	-1
	-1 FR		-12		-2
	-2		-14		-3
	-2 FR		-16		-4
	-3		-18		-5
	-3 FR				-6
	-4				-7
	-4 FR				-8
	-5				-9
	-5 FR				-10
	-6				-11
	-6 FR				-12
	-7				-13
	-7 FR				-14
	-8				-15
	-8 FR				-16
	-9				-17
	-9 FR				-18
	-10				-19
	-10 FR				-20
	-11				-21
	-12				-22
	-13				-23
	-14				-24
	-15				
	-16				
	-17				
	-18				
	-19				
	-20				
	-21				

2. PRESENTATION OF RESULTS

The induced polarization and resistivity results are shown on the following data plots in the manner described in the notes preceding this report.

Line 88N	500 foot spreads	Dwg. IP 5563-1
Line 80N	500 foot spreads	Dwg. IP 5563-2
Line 72N	500 foot spreads	Dwg. IP 5563-3
Line 64N	500 foot spreads	Dwg. IP 5563-4
Line 56N	500 foot spreads	Dwg. IP 5563-5

Line 48N	500 foot spreads	Dwg. IP 5563-6
Line 40N	500 foot spreads	Dwg. IP 5563-7
Line 36N	500 foot spreads	Dwg. IP 5563-8
Line 28N	500 foot spreads	Dwg. IP 5563-9
Line 20N	500 foot spreads	Dwg. IP 5563-10
Line 12N	500 foot spreads	Dwg. IP 5563-11
Line 4N	500 foot spreads	Dwg. IP 5563-12
Line 4N	200 foot spreads	Dwg. IP 5563-13
Line 0	200 foot spreads	Dwg. IP 5563-14
Line 4S	500 foot spreads	Dwg. IP 5563-15
Line 4S	200 foot spreads	Dwg. IP 5563-16
Line 8S	200 foot spreads	Dwg. IP 5563-17
Line 12S	500 foot spreads	Dwg. IP 5563-18
Line 20S	500 foot spreads	Dwg. IP 5563-19
Road	200 foot spreads	Dwg. IP 5563-20

Enclosed with this report is Dwg. I. P. P. 4675, a plan map of the grid at a scale of 1" = 600'. The definite and possible induced polarization anomalies are indicated by solid and broken bars respectively on this plan map as well as the data plots. These bars represent the surface projection of the anomalous zones as interpreted from the location of the transmitter and receiver electrodes when the anomalous values were measured.

Since the induced polarization measurement is essentially an averaging process, as are all potential methods, it is frequently difficult to exactly pinpoint the source of an anomaly. Certainly, no anomaly can be

located with more accuracy than the spread length; i. e. when using 500' spreads the position of a narrow sulphide body can only be determined to lie between two stations 500' apart. In order to locate sources at some depth, larger spreads must be used, with a corresponding increase in the uncertainties of location. Therefore, while the centre of the indicated anomaly probably corresponds fairly well with source, the length of the indicated anomaly along the line should not be taken to represent the exact edges of the anomalous material.

The location of survey lines relative to the claim boundaries and the names and relative positions of the claims indicated on the map are based on information supplied by the professional staff of Blue Rock Mining Corporation Ltd.

3. DISCUSSION OF RESULTS

Line 88N

The IP results from this line are characterized by moderately high resistivities and frequency effects, with weakly anomalous Metal Factor values from the Base Line to at least station 20W. This suggests a broad shallow zone of sparse metallic mineralisation that would probably not be of economic interest unless there were a high proportion of ore minerals to barren sulphides.

Line 80N

A shallow definite anomaly of moderate magnitude is centred between 0+00 and 5+00W, coincident with the quartz diorite; this feature

has been identified as Zone A on the accompanying plan, Dwg.I, P. P. 4675.

There is also a probable deep source centred at 10E and a possible shallow source at 15E to 20E but the data is incomplete. It is not entirely clear whether there are three separate features present, or if these anomalies represent stronger sections within a broad zone of weak mineralization.

Line 72N

Zone A is stronger and broader than on the preceding line, with the strongest section between the Base Line and 5W. A second definite anomaly, but of lower magnitude, is centred at 15E. This feature, identified as Zone B, is at moderate depth and has a weaker extension to the east end of the traverse.

Line 64N

Similar results were obtained on this line although Zone A is not quite as strong.

Line 56N

On this line Zone A is weaker again and is centred 500 feet further west, but Zone B is similar to the two preceding lines. Anomalous IP effects were measured on the wide separations ($n = 4$ and 5) between these two zones indicating either a third deep source or continuity between Zone A and Zone B at depth.

Line 48N

Zone A is still definite and centred at 5W but the magnitude is lower

again. Zone B has either terminated or has been displaced to the east; to resolve this ambiguity it would be necessary to extend Line 48N farther east and also to survey Line 52N.

Line 40N

On this line, Zone A is similar to Line 48N. There is also a definite anomaly of moderate magnitude at the east end of the line but its exact location is uncertain as the data is incomplete. This feature is shown as Zone C on the accompanying plan.

Line 36N

These results are very similar to those obtained on Line 40N.

Line 28N

Zone A is somewhat stronger here, with the best section between 5E and 5W. The source of the anomaly should have been adequately explained by drill holes C-5, C-6, C-7 and C-8. The traverse was too short to test the southern extension of Zone C.

Line 20N

These results are very similar to those from the previous line. However, the strongest section of the anomaly is too far east to have been tested by drill holes C-1 and C-3.

Line 12N

Here Zone A is very broad and slightly weaker.

Line 4N

Only minor IP effects were measured on the west part of Line 4N, indicating that Zone A has terminated. A definite, but incomplete, anomaly occurs at 35E to 40E within the area underlain by clastic sediments. This feature has been identified as Zone D.

The eastern section of the line was surveyed with 200-foot electrode intervals and a broad anomaly was located, suggesting a shallow source of low metallic mineral content.

Line 0

This line was surveyed only with 200-foot dipoles and anomalous effects were measured from about 34E to 66E, including a strong section at the western edge (i. e. Zone D). In general, the results show low resistivities and low background IP effects in contrast with the moderately high resistivities encountered over the igneous rocks.

Line 4S

With 500-foot spreads, Zone A appears as a strong shallow narrow anomaly centred at 40E, but with 200-foot spreads the source is wide and complex. This zone has been tested by drill hole C-4 and shown to be caused by pyritic sediments of no economic interest.

Line 8S

Similar results were obtained here using 200-foot electrode intervals although Zone D is not quite as strong.

Line 12S

Only weak effects were measured on Line 12S, with 500-foot dipoles, but the traverse did not extend far enough east to test the main part of Zone D.

Line 20S

Anomalous effects were measured on the wide separations from about 10W to the east end of the traverse, indicating a weak source at depth.

Road Traverse

A section of the road was surveyed using 200-foot intervals but unfortunately, we do not have any points to tie this in to the grid. Weakly anomalous IP effects were measured on most of the line, with the strongest section at depth under stations 44E and 46E.

4. SUMMARY AND RECOMMENDATIONS

The IP survey of the Big Onion Property has outlined four anomalous zones. Of these, Zone A appears to be of greatest interest because of its strength, extent and correlation with the siliceous igneous rocks (i. e. quartz diorite, quartz porphyry and silicified andesite). This feature has already been tested in part by several drill holes between Line 16N and Line 36N, but the strongest results were obtained on Line 72N and further drilling is recommended on this line. Since the source of Zone A is shallow (i. e. less than one unit, or 500', deep) some lines might have been detailed with shorter electrode intervals, say 300 feet. In the absence of this information, further drilling should consist of a complete cross-section of inclined holes or a fence of vertical holes.

Line 12S

Only weak effects were measured on Line 12S, with 500-foot dipoles, but the traverse did not extend far enough east to test the main part of Zone D.

Line 20S

Anomalous effects were measured on the wide separations from about 10W to the east end of the traverse, indicating a weak source at depth.

Road Traverse

A section of the road was surveyed using 200-foot intervals but unfortunately, we do not have any points to tie this in to the grid. Weakly anomalous IP effects were measured on most of the line, with the strongest section at depth under stations 44E and 46E.

4. SUMMARY AND RECOMMENDATIONS

The IP survey of the Big Onion Property has outlined four anomalous zones. Of these, Zone A appears to be of greatest interest because of its strength, extent and correlation with the siliceous igneous rocks (i. e. quartz diorite, quartz porphyry and silicified andesite). This feature has already been tested in part by several drill holes between Line 16N and Line 36N, but the strongest results were obtained on Line 72N and further drilling is recommended on this line. Since the source of Zone A is shallow (i. e. less than one unit, or 500', deep) some lines might have been detailed with shorter electrode intervals, say 300 feet. In the absence of this information, further drilling should consist of a complete cross-section of inclined holes or a fence of vertical holes.

Zone B occurs to the east of Zone A and extends from at least Line 56N to Line 72N. This feature correlates in part with the igneous rocks and in part with the clastic sediments. If the source is not known from surface investigations, a drill hole is recommended on Line 72N or Line 64N, to pass under station 15E at a vertical depth of about 500 feet.

Zone C is situated to the south and east of Zone B and may be the offset extension of Zone B rather than a separate feature. (Note that Zone A appears to be offset between Line 48N and Line 56N). Unfortunately, the anomalous patterns are not complete since the traverses do not extend far enough east, but an inclined hole might be drilled to sample the interval between 15E and 20E on Line 40N.

Zone D occurs in the south-central part of the grid and is entirely within the area underlain by the sediments. Drill hole C-4 on Line 45 intersected pyritic sediments so that further investigation of this zone would not be warranted.

McPHAR GEOPHYSICS LIMITED

Robert A. Bell

**Robert A. Bell,
Geologist**

Philip G. Hallett
**Philip G. Hallett,
Geophysicist**

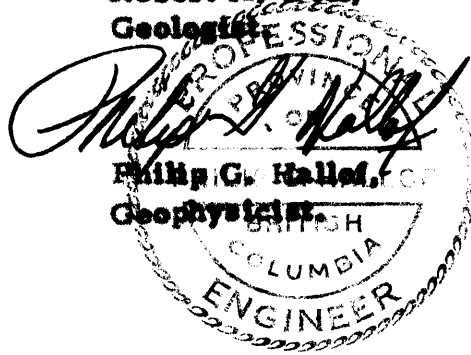

Dated: October 14, 1970

Expiry Date: February 25, 1971

ASSESSMENT DETAILS

PROPERTY: Big Onion
SPONSOR: Blue Rock Mining Corporation Ltd.
LOCATION: Smithers Area
TYPE OF SURVEY: Induced Polarization
OPERATING MAN DAYS: 106
EQUIVALENT 8 HR. MAN DAYS: 159
CONSULTING MAN DAYS: 3
DRAUGHTING MAN DAYS: 9
TOTAL MAN DAYS: 171
MINING DIVISION: Omineca
PROVINCE: British Columbia
DATE STARTED: June 1, 1970
DATE FINISHED: Aug. 31, 1970
NUMBER OF STATIONS: 397
NUMBER OF READINGS: 3624
MILES OF LINE SURVEYED: 27.4

CONSULTANTS:

Robert A. Bell, 50 Hemford Crescent, Don Mills, Ontario.
Phillip G. Hallof, 5 Minorca Place, Don Mills, Ontario.

FIELD TECHNICIANS:

J. Tomenchuk, 347 Perth Avenue, Toronto, Ontario.
R. Mertens, 304 Holmes Avenue, Willowdale, Ontario.

Plus Extra Labour:

C. Sykes, Box 2326, Smithers, British Columbia.
R. Bailey, 94N Broadway, Smithers, British Columbia.
I. Uipond, c/o Carew McFall, of Cyprus Expl. 1572 Vining St. Victoria, B.C.
J. Wookey, Box 761, Smithers, British Columbia.

DRAUGHTSMEN:

J. Dejc, 20 Roselawn Avenue, Toronto, Ontario.
F. Hurst, 230 Woburn Avenue, Toronto 12, Ontario.

McPHAR GEOPHYSICS LIMITED

Robert A. Bell,
Geologist.

Dated: October 14, 1970

STATEMENT OF COST

Blue Rock Mining Corporation Ltd.
Big Onion Property, Smithers Area, B. C.
Omineca Mining Division

Crew - 2 men - J. Tomenchuk) June 1st - 15th
- R. Mertens)
- R. Mertens) July 8th - 16th
- F. Glass) August 19th - 31st

26½ days Operating	@ \$240.00/day	\$ 6,360.00
2½ days Bad Weather)		
5 days Travel)	16½ days @ \$100.00/day	1,650.00
2 days Preparation)		
7 days Standby)		
4 days Standby		
		<u>N. C.</u>
		\$ 8,010.00

Extra Labour	\$486.25	
Plus 20%	<u>97.25</u>	
	583.50	583.50

<u>Expenses</u>		
Air Fare	472.00	
Taxis	24.00	
Rented Vehicles	703.59	
Vehicle Expense	41.16	
Excess Baggage	36.84	
Meals and Accommodation	1,338.69	
Telephone and Telegraph	104.19	
Supplies	133.08	
Miscellaneous	9.00	
Freight and Brokerage	<u>866.82</u>	
	3,729.37	
Plus 10%	<u>372.93</u>	
	4,102.30	
		<u>4,102.30</u>
		\$12,695.80

McPHAR GEOPHYSICS LIMITED

Robert A. Bell
Robert A. Bell,
Geologist.

Dated: October 14, 1970

CERTIFICATE

I, Robert Alan Bell, of the City of Toronto, Province of Ontario,
do hereby certify that:

1. I am a geologist residing at 50 Hemford Crescent, Don Mills,
(Toronto) Ontario.

2. I am a graduate of the University of Toronto in Physics and
Geology with the degree of Bachelor of Arts (1949); and a graduate of
the University of Wisconsin in Economic Geology with the degree of Ph.D.
(1953).

3. I am a member of the Society of Economic Geologists and a
fellow of the Geological Association of Canada.

4. I have been practising my profession for over fifteen years.

5. I have no direct or indirect interest, nor do I expect to receive
any interest directly or indirectly, in the property or securities of Blue
Rock Mining Corporation Ltd. or any affiliate.

6. The statements made in this report are based on a study of
published geological literature and unpublished private reports.

7. Permission is granted to use in whole or in part for assessment
and qualification requirements but not for advertising purposes.

Dated at Toronto

This 14th day of October 1970

Robert A. Bell, Ph.D.

CERTIFICATE

I, Philip George Hallof, of the City of Toronto, Province of Ontario, do hereby certify that:

1. I am a geophysicist residing at 5 Minorca Place, Don Mills, (Toronto) Ontario.
2. I am a graduate of the Massachusetts Institute of Technology with a B.Sc. Degree (1952) in Geology and Geophysics, and a Ph.D. Degree (1957) in Geophysics.
3. I am a member of the Society of Exploration Geophysicists and the European Association of the Exploration Geophysicists.
4. I am a Professional Geophysicist, registered in the Province of Ontario, the Province of British Columbia and the State of Arizona.
5. I have no direct or indirect interest, nor do I expect to receive any interest directly or indirectly, in the property or securities of Blue Rock Mining Corporation Ltd. or any affiliate.
6. The statements made in this report are based on a study of published geological literature and unpublished private reports.
7. Permission is granted to use in whole or in part for assessment and qualification requirements but not for advertising purposes.

Dated at Toronto

This 14th day of October 1970

Philip G. Hallof, Ph.D.

Expiry Date: February 28, 1971

McPHAR GEOPHYSICS
 INDUCED POLARIZATION AND RESISTIVITY SURVEY
 PLAN MAP

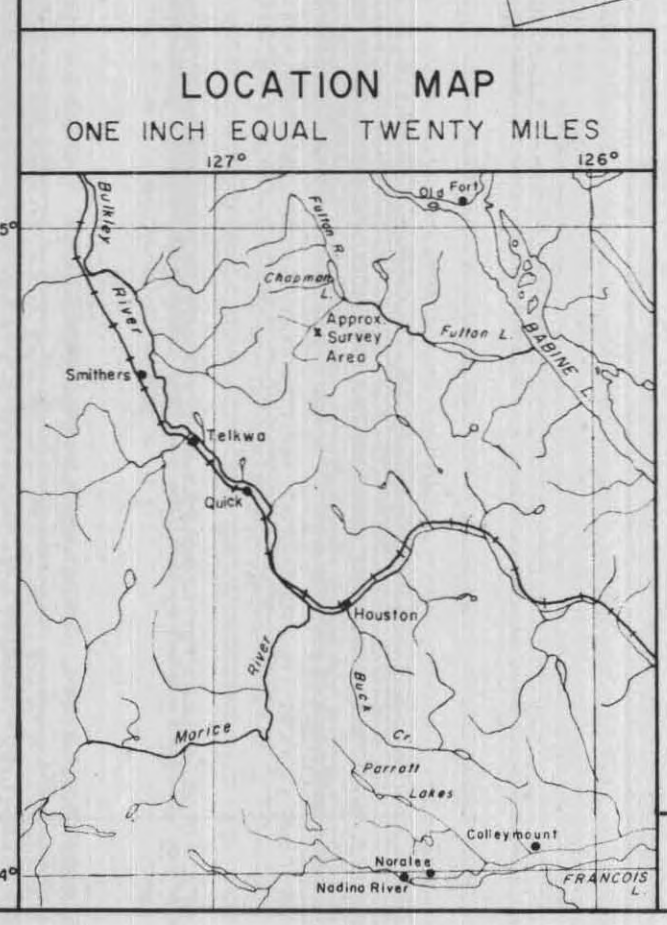
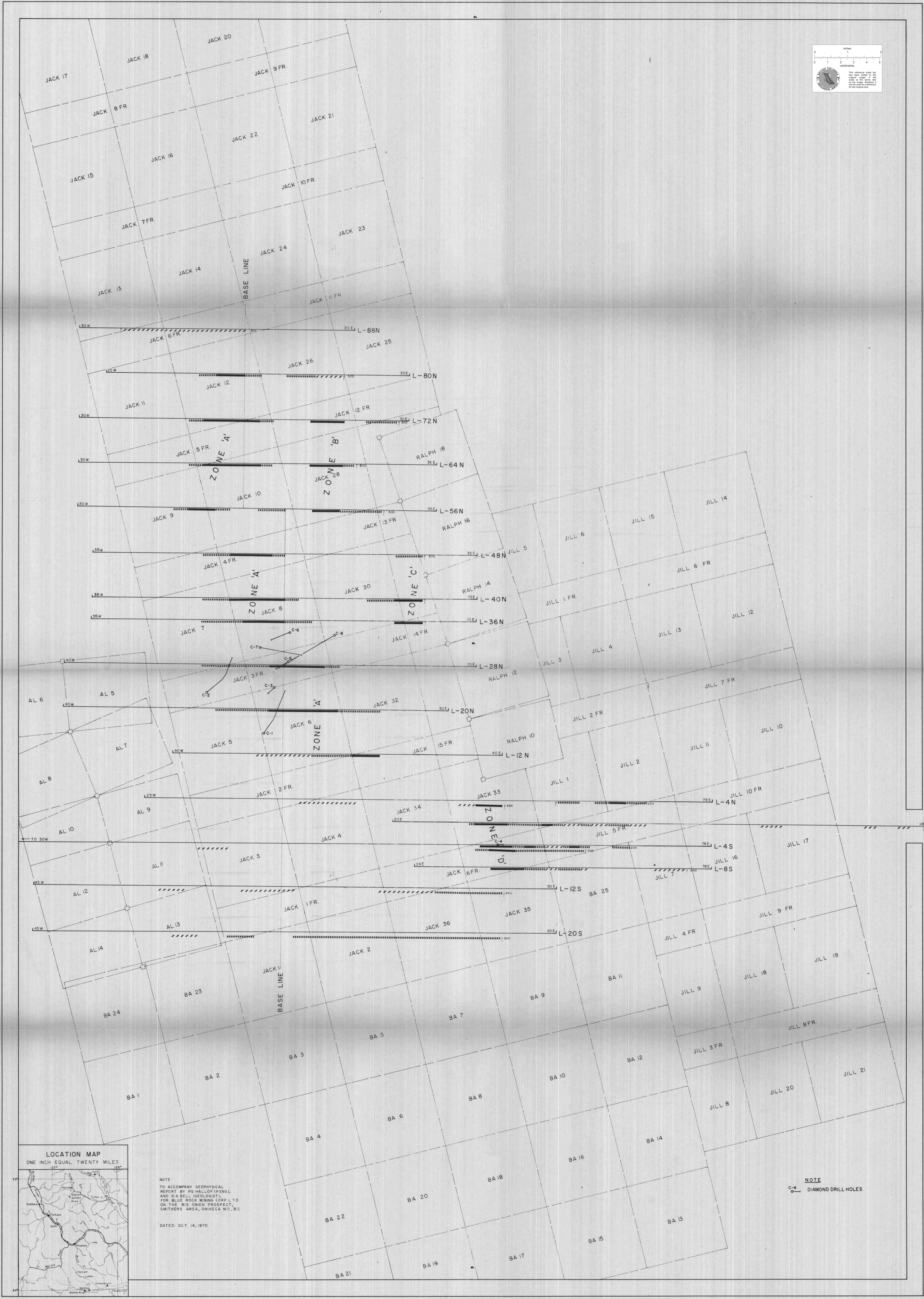
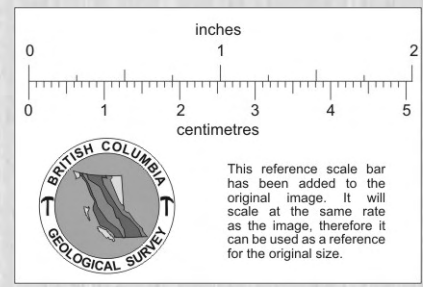

NOTE:
 TO ACCOMPANY GEOPHYSICAL
 REPORT BY PG HALLOP (PENG),
 AND R. A. BELL (GEOLOGIST),
 FOR BLUE ROCK MINING CORP. LTD.
 ON THE BIG ONION PROSPECT,
 SMITHERS AREA, OMINECA M.D., B.C.

DATED OCT. 14, 1970

NOTE
 C-4 DIAMOND DRILL HOLES

SURFACE PROJECTION
 OF ANOMALOUS ZONES
 DEFINITE
 PROBABLE
 POSSIBLE
 Number at the end of column
 indicates spread used

BLUE ROCK MINING CORPORATION LTD.

BIG ONION PROSPECT, SMITHERS AREA
 OMINECA M.D., B.C.

SCALE

One Inch = Six Hundred Feet



BLUE ROCK MINING CORPORATION LTD.

BIG ONION PROSPECT
SMITHERS AREA
OMINECA M.D., B.C.

LINE NO. - 88N

ELECTRODE CONFIGURATION

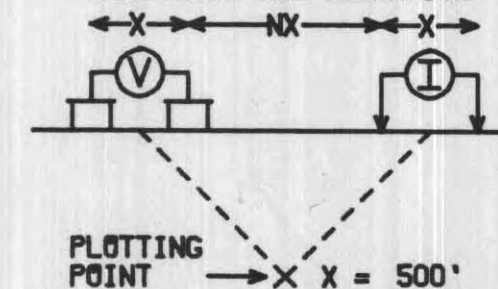

SURFACE PROJECTION OF ANOMALOUS ZONES

DEFINITE **—————**
PROBABLE **.....**
POSSIBLE **//////**

FREQUENCIES: 0.31-5.0 CPS

DATE SURVEYED: SEPT '70

APPROVED:

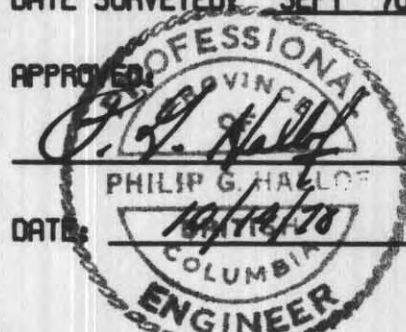

DATE:

Expiry Date: February 25, 1971

NOTE: CONTOURS AT LOGARITHMIC INTERVALS 1.-1.5-2.-3.-5.-7.5-10

McPHAR GEOPHYSICS

INDUCED POLARIZATION AND RESISTIVITY SURVEY

NOTE: THIS PLOT WAS PRODUCED WITH AN IBM 360/75 COMPUTER AND A CALCOMP PLOTTER

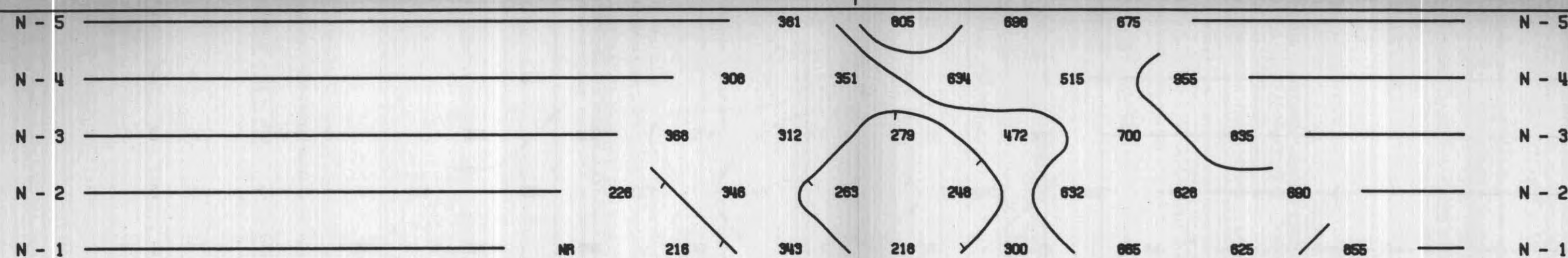

RESISTIVITY (APP.) IN OHM FEET / 2π

RESISTIVITY (APP.) IN OHM FEET / 2π

30W 25W 20W 15W 10W 5W 0 5E 10E 15E 20E

METAL FACTOR (APP.)

METAL FACTOR (APP.)

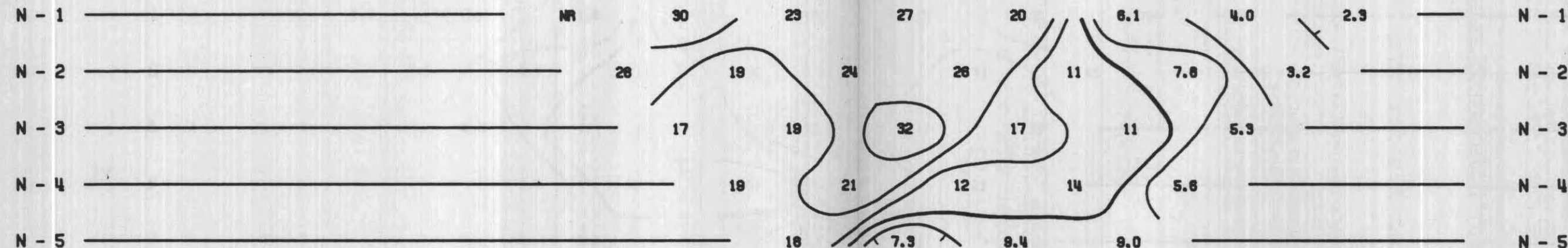

FREQUENCY EFFECT (APP.) IN %

FREQUENCY EFFECT (APP.) IN %

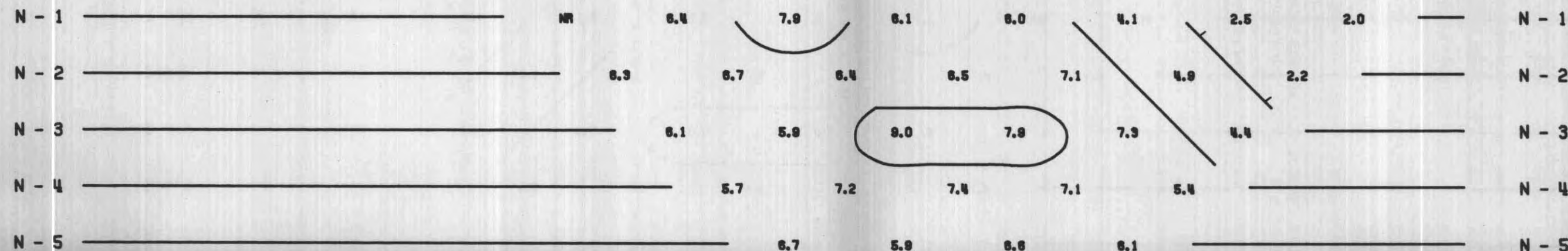

BLUE ROCK MINING CORPORATION LTD.

BIG ONION PROSPECT
SMITHERS AREA
OMINECA M.D., B.C.

LINE NO. - 80N

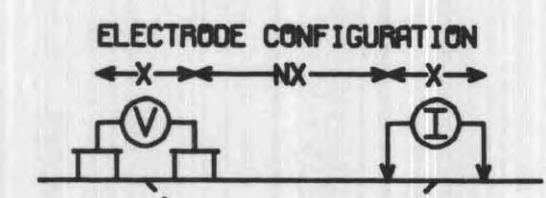

PLOTTING POINT → X X = 500'

SURFACE PROJECTION OF ANOMALOUS ZONES

DEFINITE

PROBABLE

POSSIBLE

FREQUENCIES: 0.31-5.0 CPS

DATE SURVEYED: AUG 1970

NOTE: CONTOURS AT LOGARITHMIC INTERVALS 1.-1.5-2.-3.-5.-7.5-10

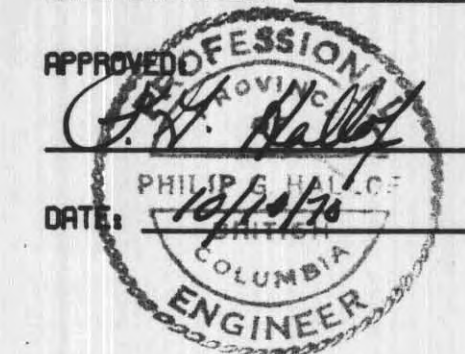

Expiry Date: February 21, 1974

McPHAR GEOPHYSICS

INDUCED POLARIZATION AND RESISTIVITY SURVEY
NOTE: THIS PLOT WAS PRODUCED WITH AN IBM 360/75 COMPUTER AND A CALCOMP PLOTTER

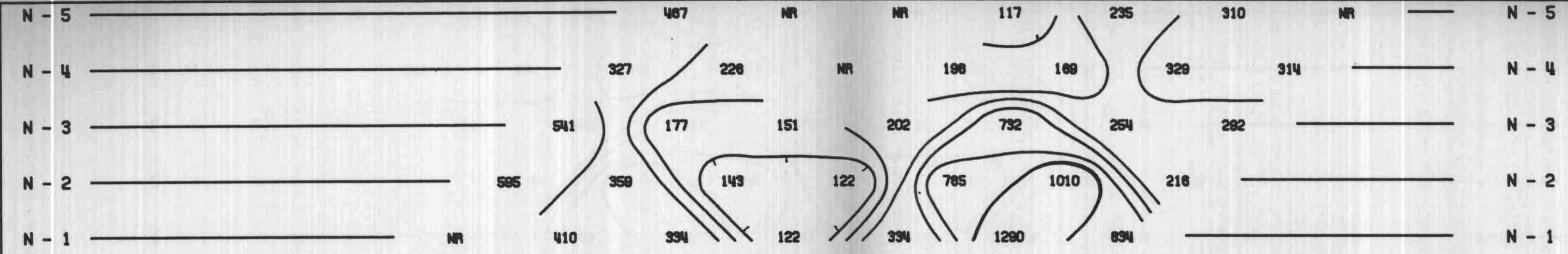

RESISTIVITY (APP.) IN OHM FEET / 2π

RESISTIVITY (APP.) IN OHM FEET / 2π



METAL FACTOR (APP.)

METAL FACTOR (APP.)

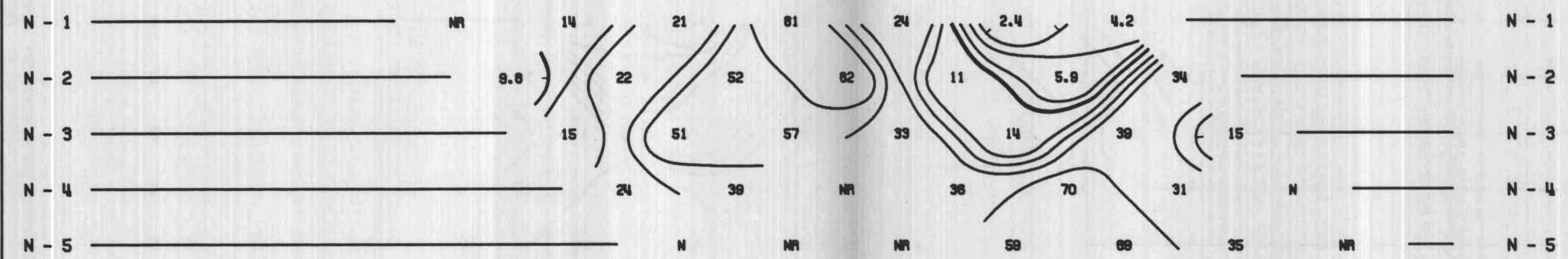

FREQUENCY EFFECT (APP.) IN %

FREQUENCY EFFECT (APP.) IN %

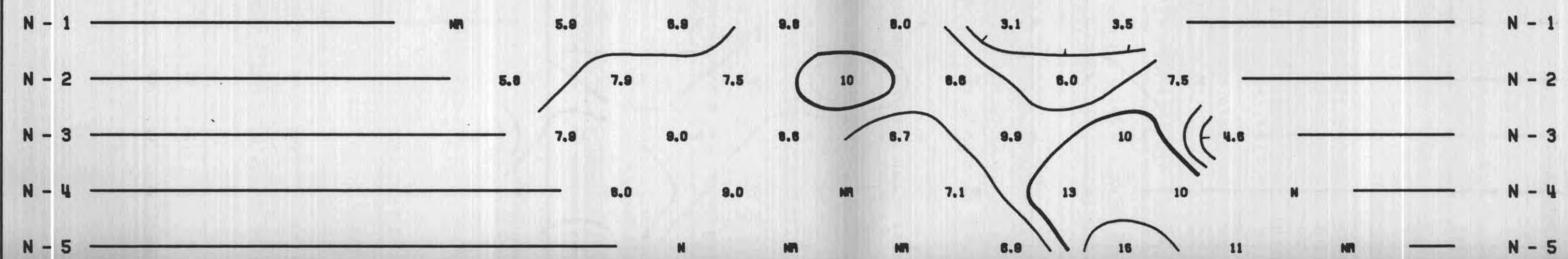

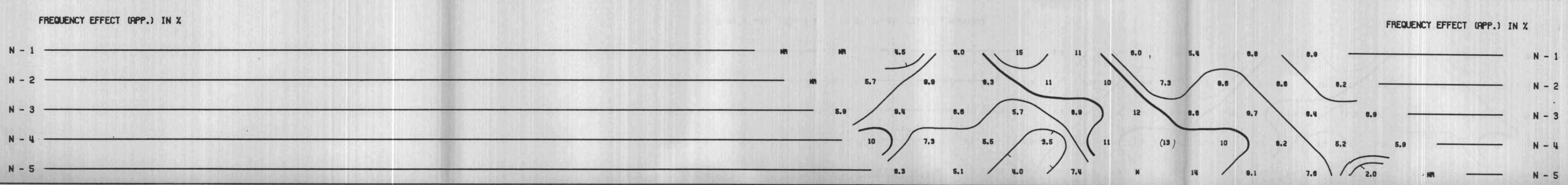
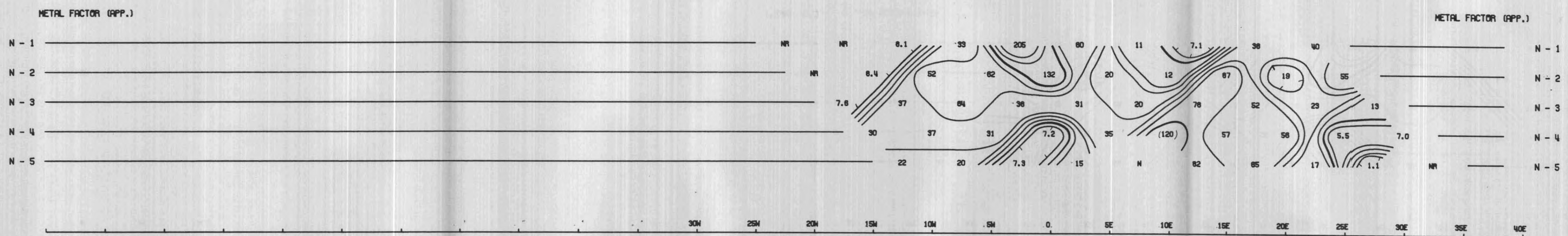
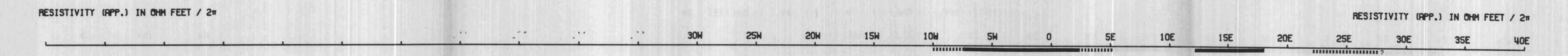
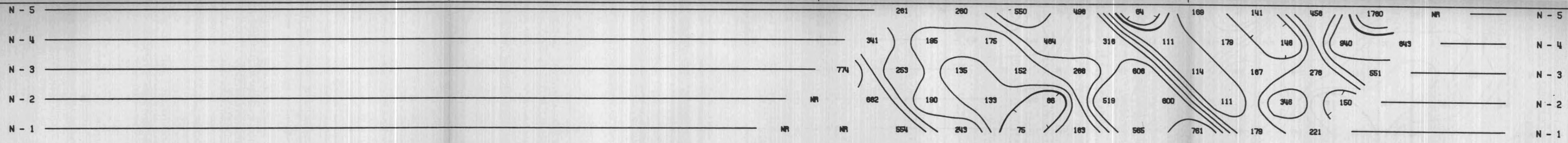

DWG. NO.- I.P.-5563-3

BLUE ROCK MINING CORPORATION LTD.

BIG ONION PROSPECT
SMITHERS AREA
OMINECA M.D., B.C.

LINE NO.- 72N

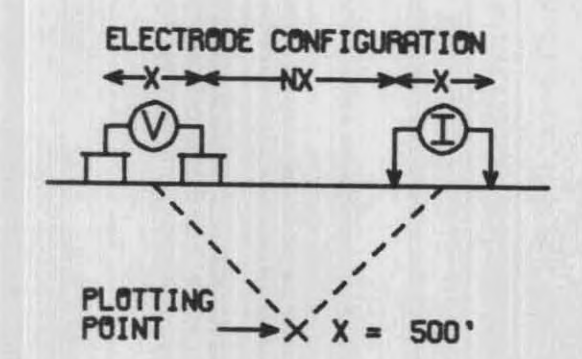

SURFACE PROJECTION OF ANOMALOUS ZONES

DEFINITE **————**

PROBABLE **|||||**

POSSIBLE **////**

FREQUENCIES: 0.31-5.0 CPS DATE SURVEYED: AUG 1970

NOTE: CONTOURS AT LOGARITHMIC INTERVALS 1.-1.5-2.-3.-5.-7.5-10

APPROVED: *Philip Chait*
PHILIP CHAIT
10/10/70
COLUMBIA ENGINEER
Expiry Date: February 25, 1971

McPHAR GEOPHYSICS

INDUCED POLARIZATION AND RESISTIVITY SURVEY

NOTE: THIS PLOT WAS PRODUCED WITH AN IBM 360/75 COMPUTER AND A CALCOMP PLOTTER

BLUE ROCK MINING CORPORATION LTD.

BIG ONION PROSPECT
SMITHERS AREA
OMINECA M.D., B.C.

LINE NO.- 64N

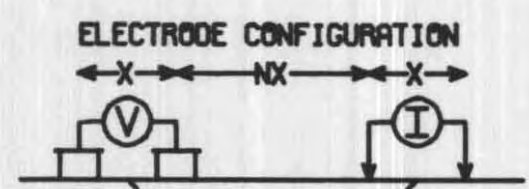

PLOTTING POINT → X X = 500'

SURFACE PROJECTION OF ANOMALOUS ZONES

DEFINITE **————**
PROBABLE **—————**
POSSIBLE **//////**

FREQUENCIES: 0.31-5.0 CPS

DATE SURVEYED: AUG 1970

APPROVED: *[Signature]*
PHILIP H. HALL
BRITISH
ENGINEER

DATE: 10/10/76
Expiry Date: February 25, 1971

NOTE: CONTOURS AT LOGARITHMIC INTERVALS 1.-1.5-2.-3.-5.-7.5-10

McPHAR GEOPHYSICS

INDUCED POLARIZATION AND RESISTIVITY SURVEY
NOTE: THIS PLOT WAS PRODUCED WITH AN IBM 360/75 COMPUTER AND A CALCOMP PLOTTER

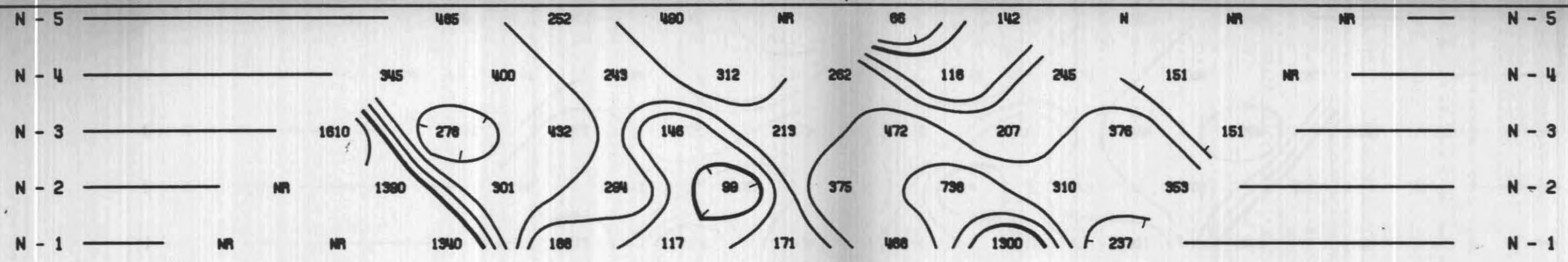

RESISTIVITY (APP.) IN OHM FEET / 2π

RESISTIVITY (APP.) IN OHM FEET / 2π

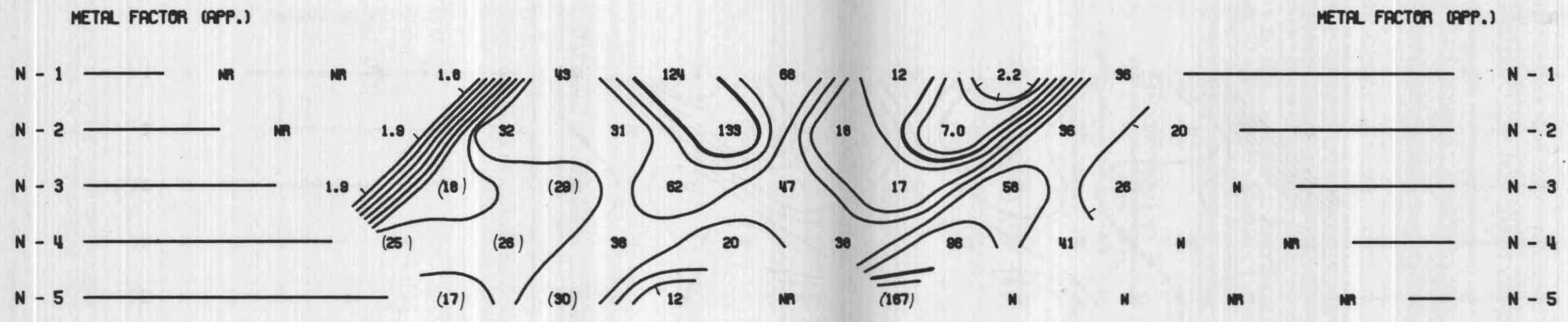

METAL FACTOR (APP.)

METAL FACTOR (APP.)

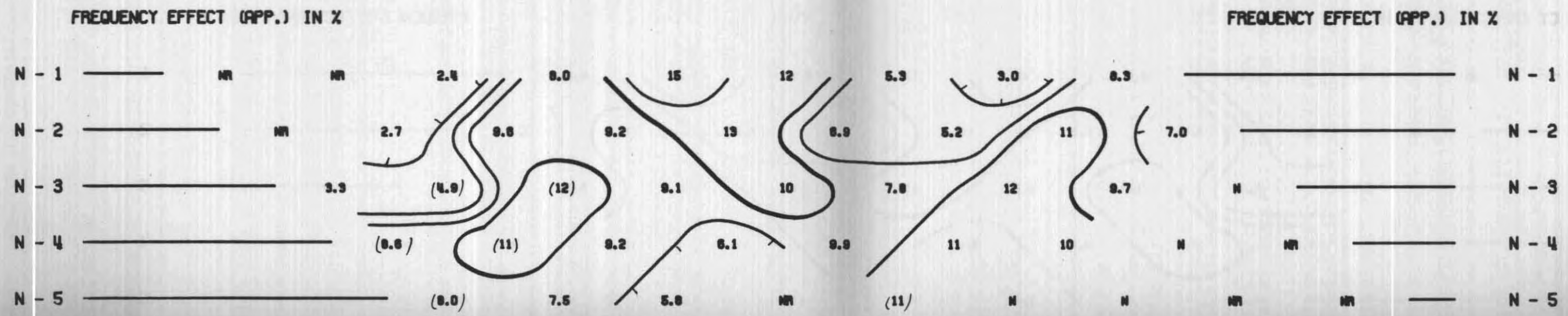

FREQUENCY EFFECT (APP.) IN %

FREQUENCY EFFECT (APP.) IN %

BLUE ROCK MINING CORPORATION LTD.

BIG ONION PROSPECT
SMITHERS AREA
OMINECA M.D., B.C.

LINE NO.- 56N

ELECTRODE CONFIGURATION

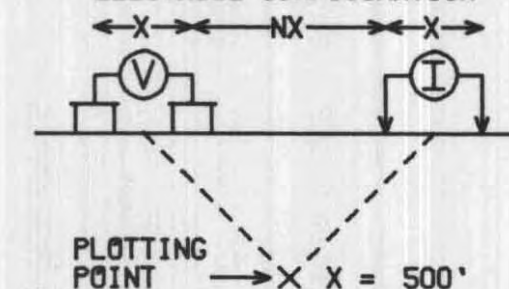

SURFACE PROJECTION OF ANOMALOUS ZONES

DEFINITE
PROBABLE
POSSIBLE

FREQUENCIES: 0.31-5.0 CPS

DATE SURVEYED: AUG 1970

APPROVED:

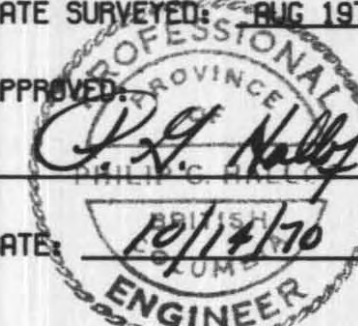

DATE: 10/14/70

Expiry Date: February 25, 1971

NOTE: CONTOURS AT LOGARITHMIC INTERVALS 1.-1.5-2.-3.-5.-7.5-10

McPHAR GEOPHYSICS

INDUCED POLARIZATION AND RESISTIVITY SURVEY

NOTE: THIS PLOT WAS PRODUCED WITH AN IBM 360/75 COMPUTER AND A CALCOMP PLOTTER

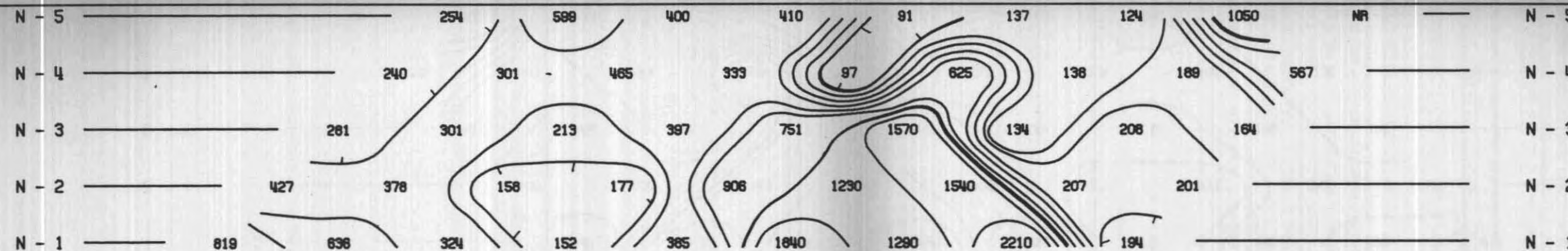

RESISTIVITY (APP.) IN OHM FEET / 2π

RESISTIVITY (APP.) IN OHM FEET / 2π

30W 25W 20W 15W 10W 5W 0 SE 10E 15E 20E 25E 30E 35E

METAL FACTOR (APP.)

METAL FACTOR (APP.)

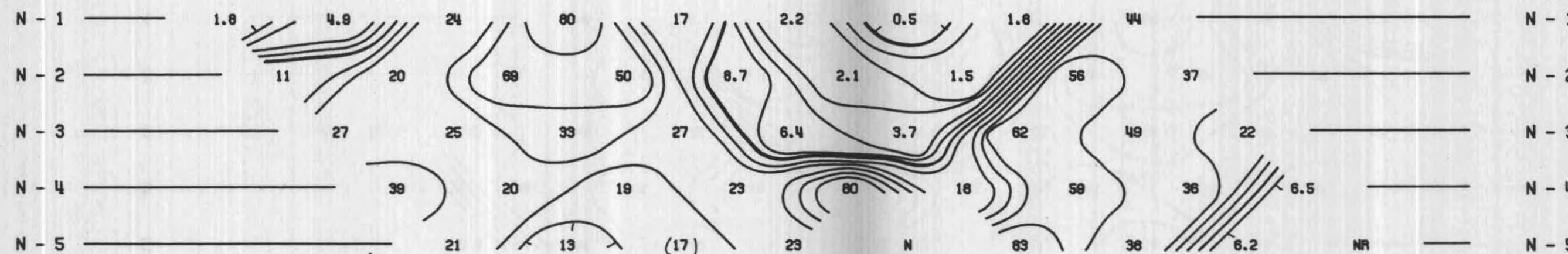

30W 25W 20W 15W 10W 5W 0 SE 10E 15E 20E 25E 30E 35E

FREQUENCY EFFECT (APP.) IN %

FREQUENCY EFFECT (APP.) IN %

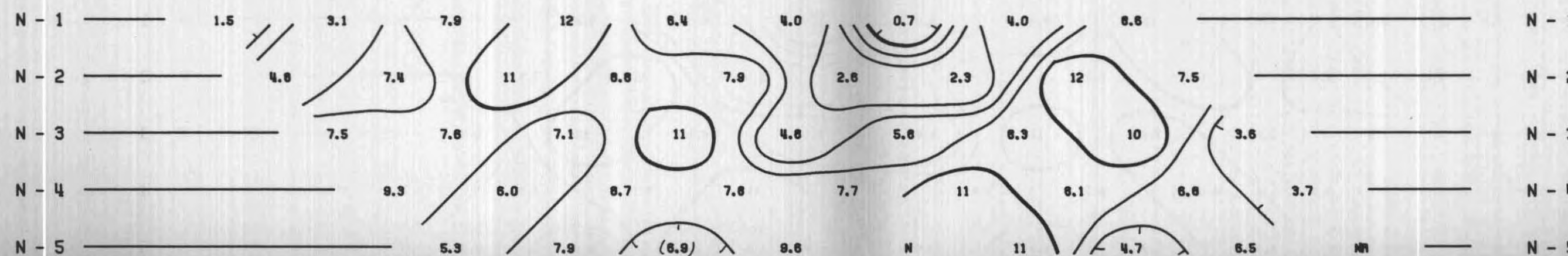

BLUE ROCK MINING CORPORATION LTD.

BIG ONION PROSPECT
SMITHERS AREA
OMINECA M.D., B.C.

LINE NO. - 48N

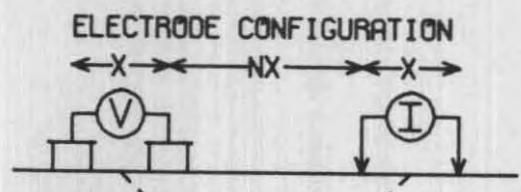

PLOTTING POINT X = 500'

SURFACE PROJECTION OF ANOMALOUS ZONES
DEFINITE
PROBABLE
POSSIBLE

FREQUENCIES: 0.31-5.0 CPS

DATE SURVEYED: AUG 1970

APPROVED:
DATE: 10/19/70
BRITISH COLUMBIA PROFESSIONAL ENGINEER

Expiry Date, February 25, 1971

NOTE: CONTOURS AT LOGARITHMIC INTERVALS 1.-1.5-2.-3.-5.-7.5-10

McPHAR GEOPHYSICS

INDUCED POLARIZATION AND RESISTIVITY SURVEY

NOTE: THIS PLOT WAS PRODUCED WITH AN IBM 360/75 COMPUTER AND A CALCOMP PLOTTER

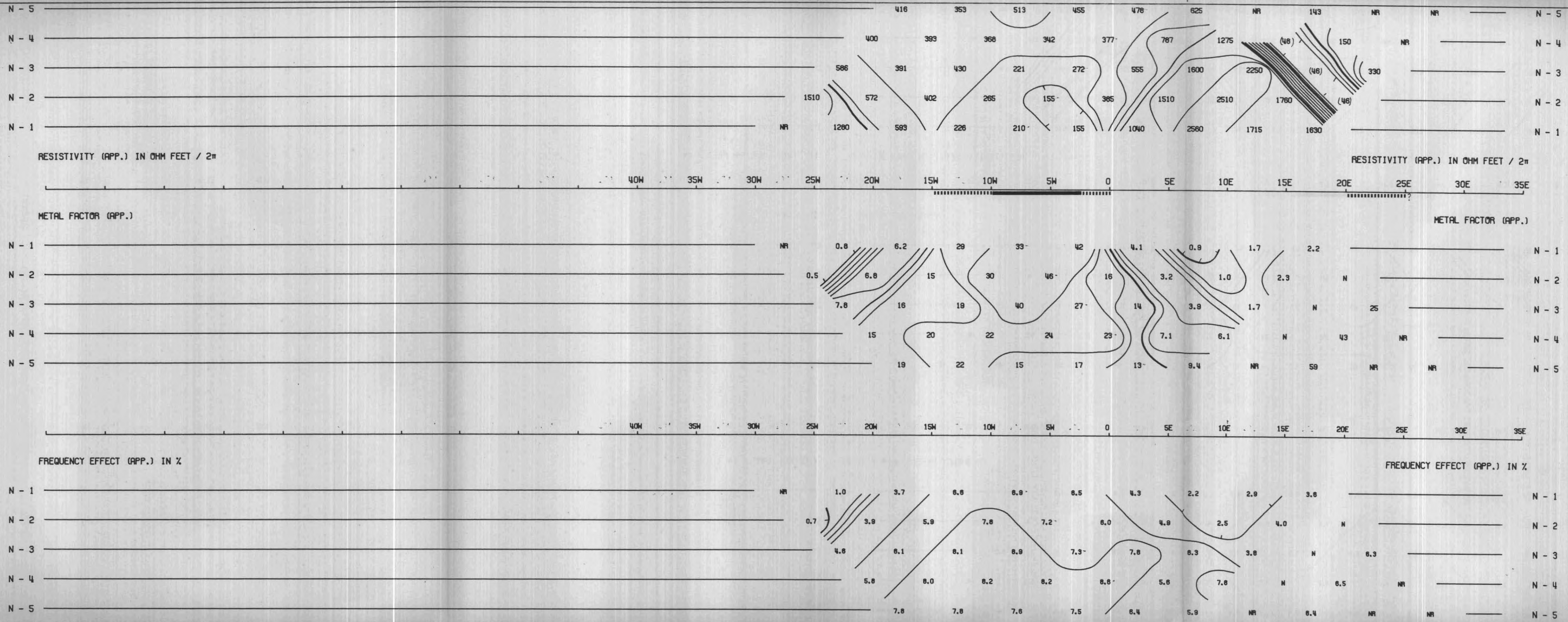

BLUE ROCK MINING CORPORATION LTD.

BIG ONION PROSPECT
SMITHERS AREA
OMINECA M.D., B.C.

LINE NO. - 40N

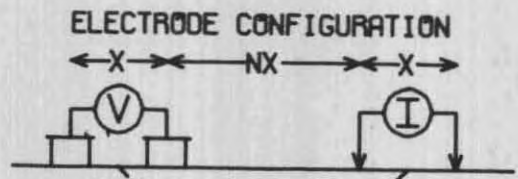

PLOTTING POINT → X X = 500'

SURFACE PROJECTION OF ANOMALOUS ZONES
DEFINITE
PROBABLE
POSSIBLE

FREQUENCIES: 0.31-5.0 CPS

DATE SURVEYED: AUG 1970

APPROVED:
DATE: 10/1/70
PROFESSIONAL ENGINEER

Expiry Date: February 25, 1971

NOTE: CONTOURS AT LOGARITHMIC INTERVALS 1.-1.5-2.-3.-5.-7.5-10

McPHAR GEOPHYSICS

INDUCED POLARIZATION AND RESISTIVITY SURVEY

NOTE: THIS PLOT WAS PRODUCED WITH AN IBM 360/75 COMPUTER AND A CALCOMP PLOTTER

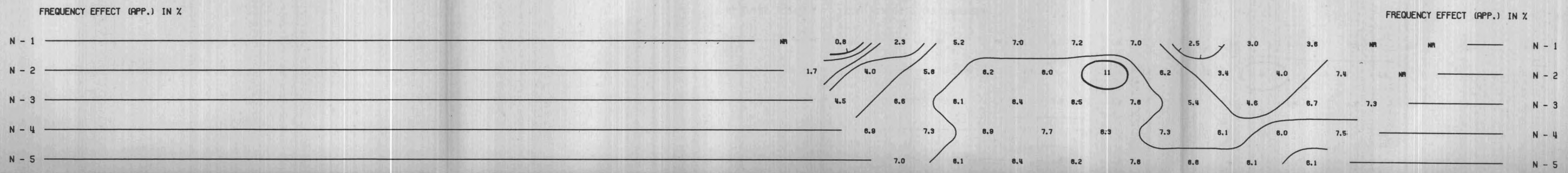
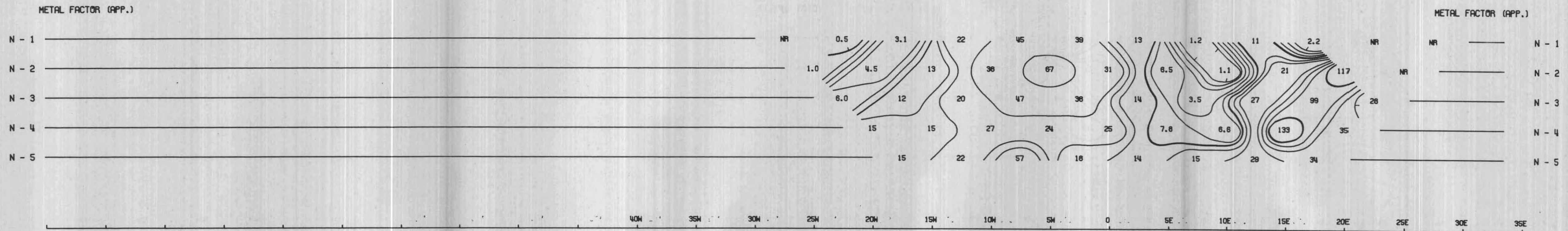
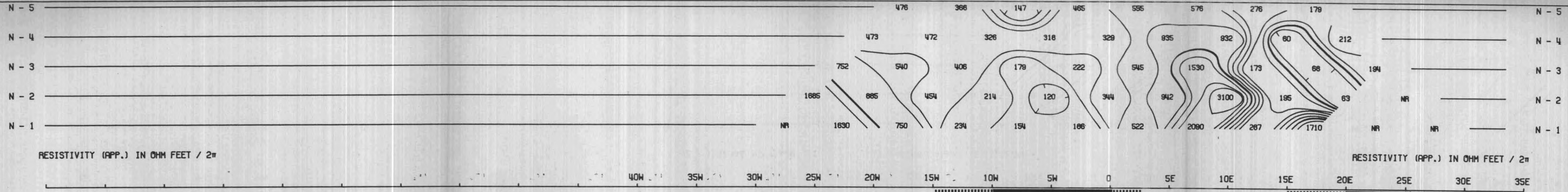

BLUE ROCK MINING CORPORATION LTD.

BIG ONION PROSPECT
SMITHERS AREA
OMINECA M.D., B.C.

LINE NO. - 36N

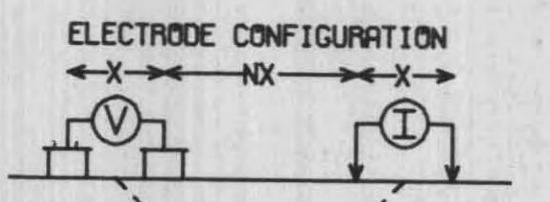

PLOTTING POINT → X X = 500'

SURFACE PROJECTION OF ANOMALOUS ZONES

DEFINITE

PROBABLE

POSSIBLE

FREQUENCIES: 0.31-5.0 CPS

DATE SURVEYED: AUG 1970

APPROVED:

DATE: 10/19/70

ENGINEER

Expiry Date: February 25, 1971

NOTE: CONTOURS AT LOGARITHMIC INTERVALS
1.-1.5-2.-3.-5.-7.5-10

McPHAR GEOPHYSICS

INDUCED POLARIZATION AND RESISTIVITY SURVEY

NOTE: THIS PLOT WAS PRODUCED WITH AN IBM 360/75 COMPUTER AND A CALCOMP PLOTTER

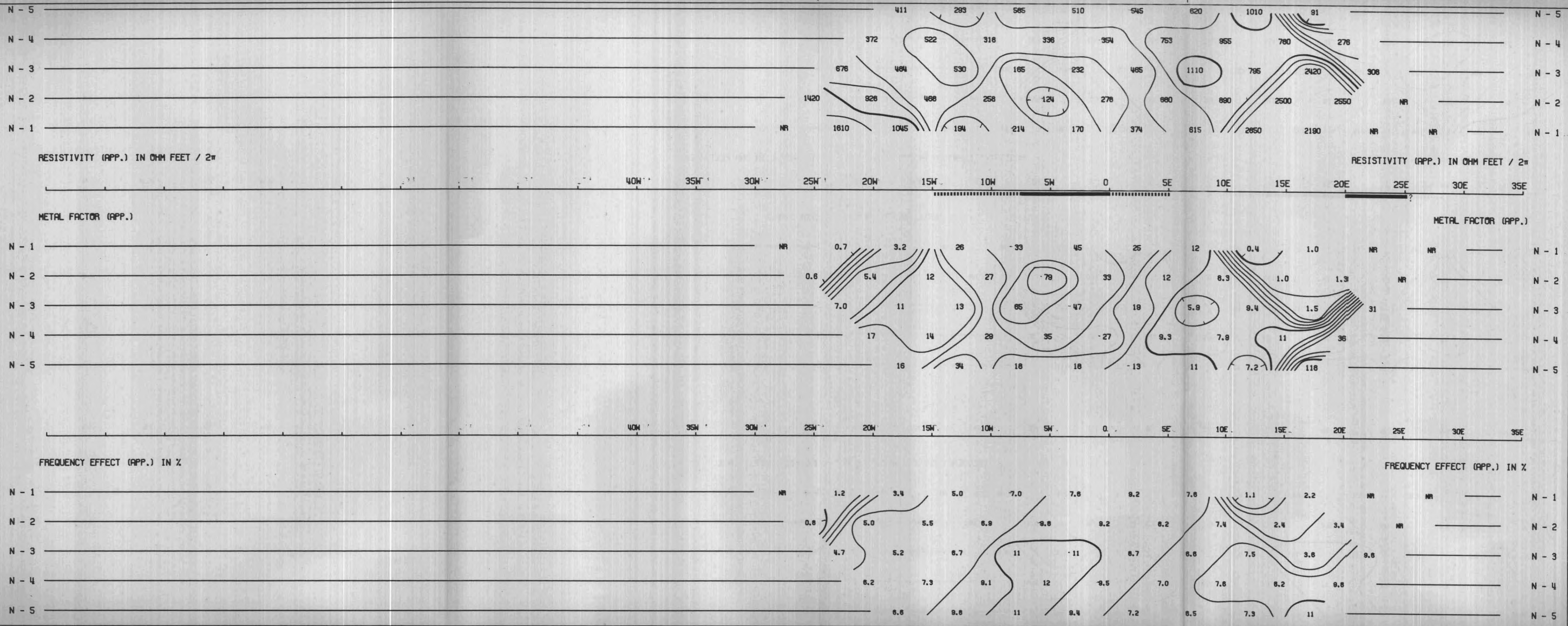

BLUE ROCK MINING CORPORATION LTD.

BIG ONION PROSPECT
SMITHERS AREA
OMINECA M.D., B.C.

LINE NO. - 28N

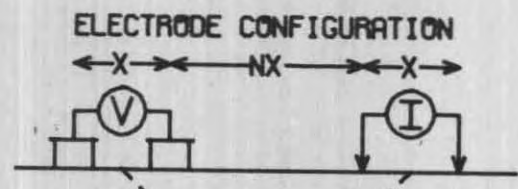

PLOTTING POINT X = 500'

SURFACE PROJECTION OF ANOMALOUS ZONES
DEFINITE **————**
PROBABLE **————**
POSSIBLE **————**

FREQUENCIES: 0.31-5.0 CPS

DATE SURVEYED: AUG 1970

APPROVED *P. H. Hally*
DATE: 10/14/70
PROFESSIONAL ENGINEER
Exp. Date: February 25, 1971

NOTE: CONTOURS AT LOGARITHMIC INTERVALS 1.-1.5-2.-3.-5.-7.5-10

McPHAR GEOPHYSICS

INDUCED POLARIZATION AND RESISTIVITY SURVEY

NOTE: THIS PLOT WAS PRODUCED WITH AN IBM 360/75 COMPUTER AND A CALCOMP PLOTTER

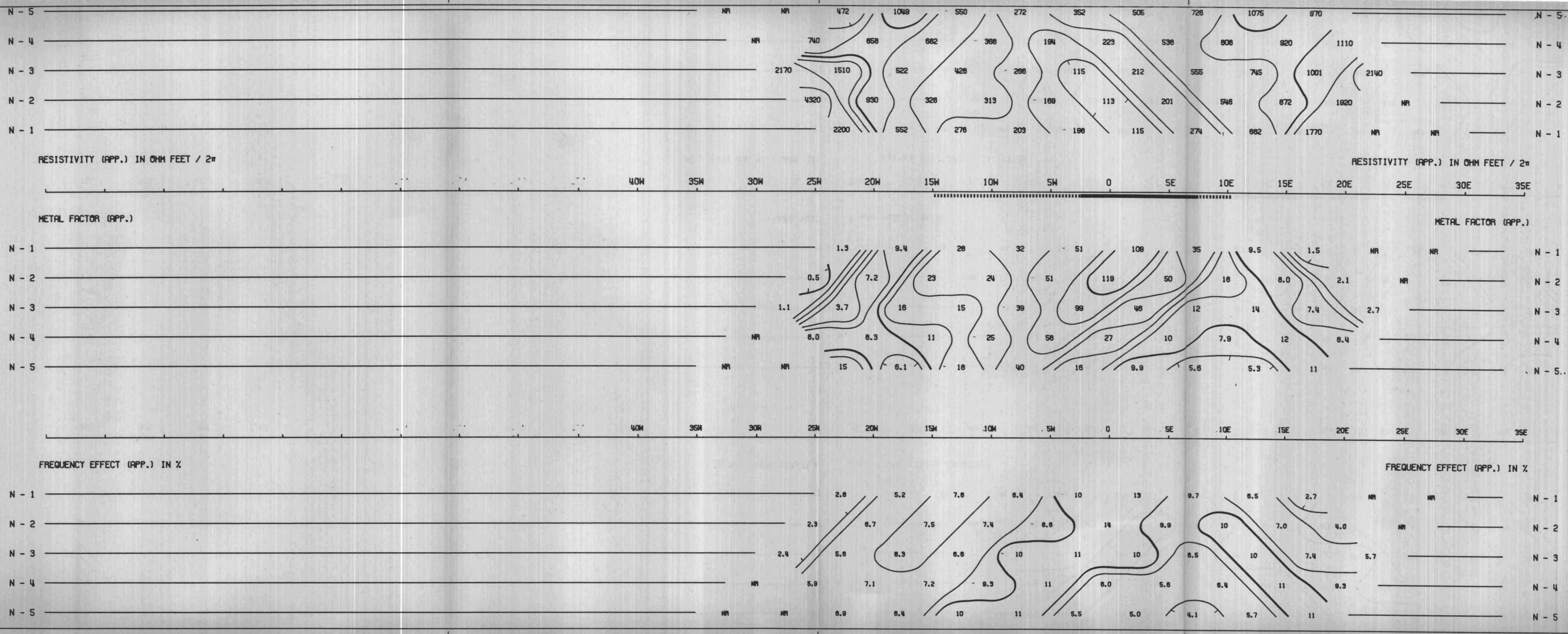

BLUE ROCK MINING CORPORATION LTD.

BIG ONION PROSPECT
SMITHERS AREA
OMINECA M.D., B.C.

LINE NO. - 20N

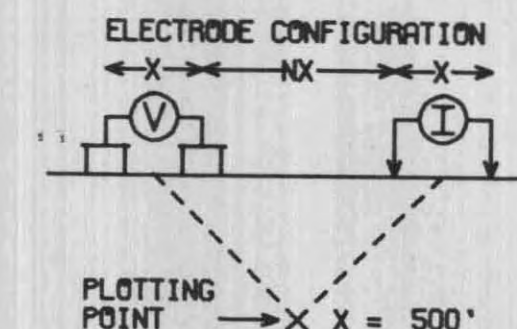

SURFACE PROJECTION OF ANOMALOUS ZONES

DEFINITE —————
 PROBABLE —————
 POSSIBLE - - - - -

FREQUENCIES: 0.31-5.0 CPS

DATE SURVEYED: AUG 1970

APPROVED: *P. G. Kelly*
 DATE: 10/10/70
 ENGINEER
 Expiry Date February 25, 1971

NOTE: CONTOURS AT LOGARITHMIC INTERVALS 1.-1.5-2.-3.-5.-7.5-10

McPHAR GEOPHYSICS

INDUCED POLARIZATION AND RESISTIVITY SURVEY

NOTE: THIS PLOT WAS PRODUCED WITH AN IBM 360/75 COMPUTER AND A CALCOMP PLOTTER

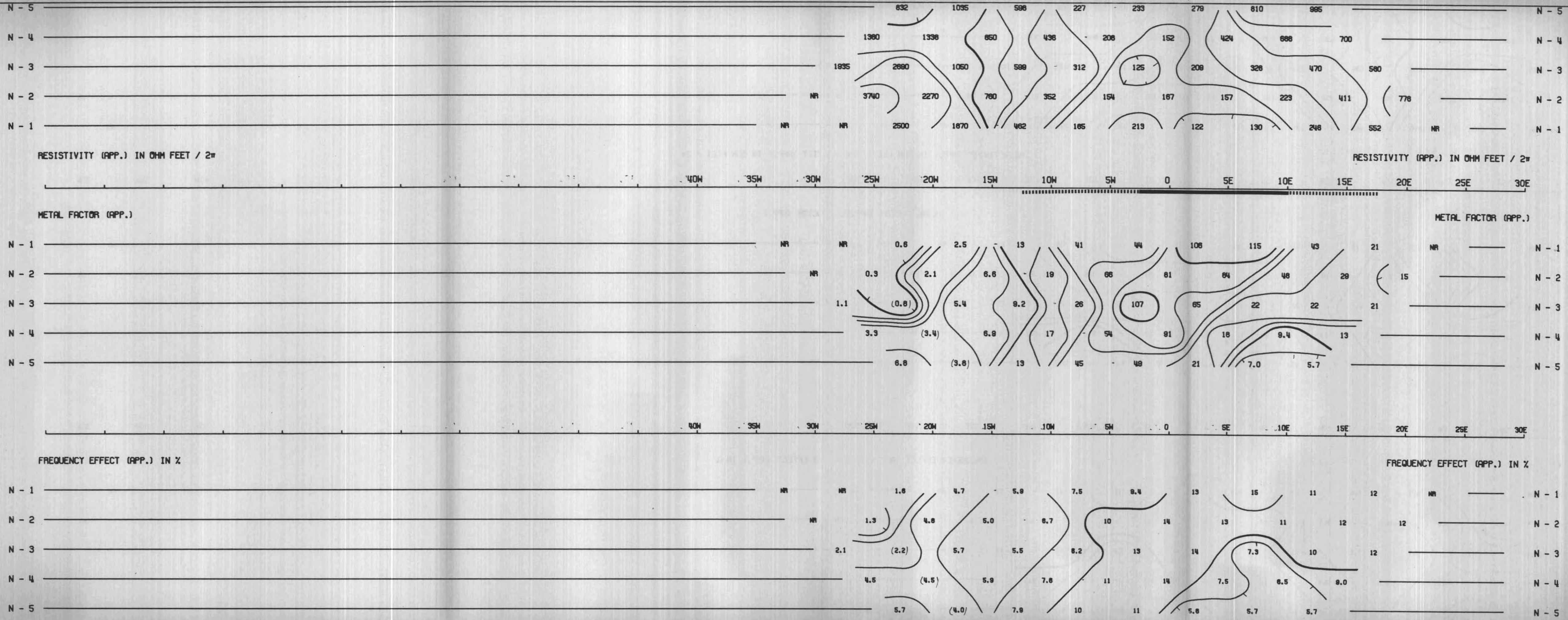

BLUE ROCK MINING CORPORATION LTD.

BIG ONION PROSPECT
SMITHERS AREA
OMINECA M.D., B.C.

LINE NO. 12N

ELECTRODE CONFIGURATION

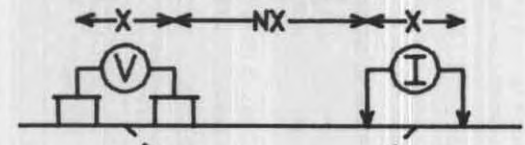

PLOTTING POINT X X = 500'

SURFACE PROJECTION OF ANOMALOUS ZONES

DEFINITE **—————**
PROBABLE **|||||**
POSSIBLE **////**

FREQUENCIES: 0.31-5.0 CPS

DATE SURVEYED: JUN 1970

APPROVED: *[Signature]*



DATE: 10/14/70

Expiry Date: February 25, 1971

NOTE: CONTOURS AT LOGARITHMIC INTERVALS 1.-1.5-2.-3.-5.-7.5-10

McPHAR GEOPHYSICS

INDUCED POLARIZATION AND RESISTIVITY SURVEY

NOTE: THIS PLOT WAS PRODUCED WITH AN IBM 360/75 COMPUTER AND A CALCOMP PLOTTER

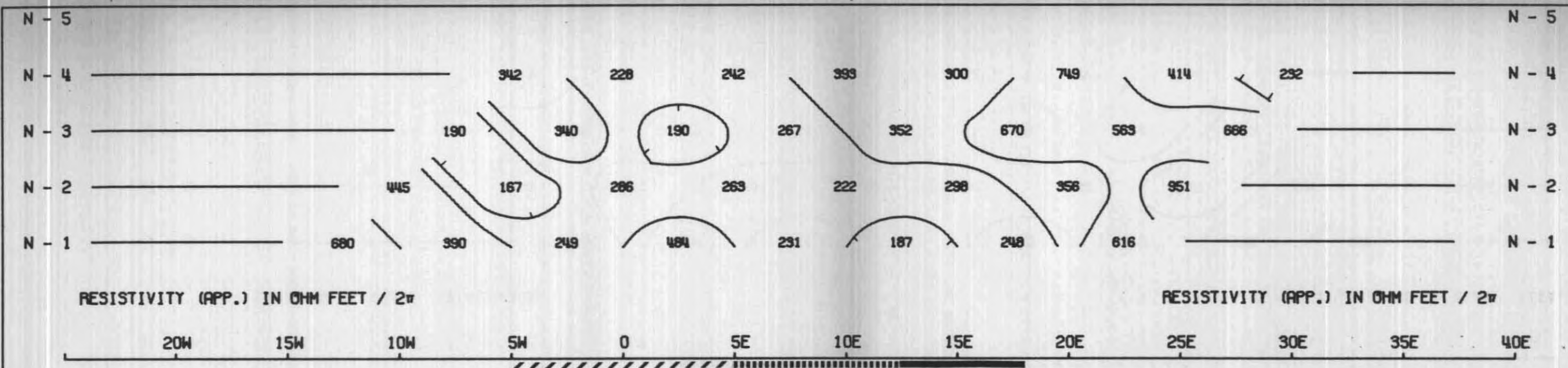

METAL FACTOR (APP.)

METAL FACTOR (APP.)

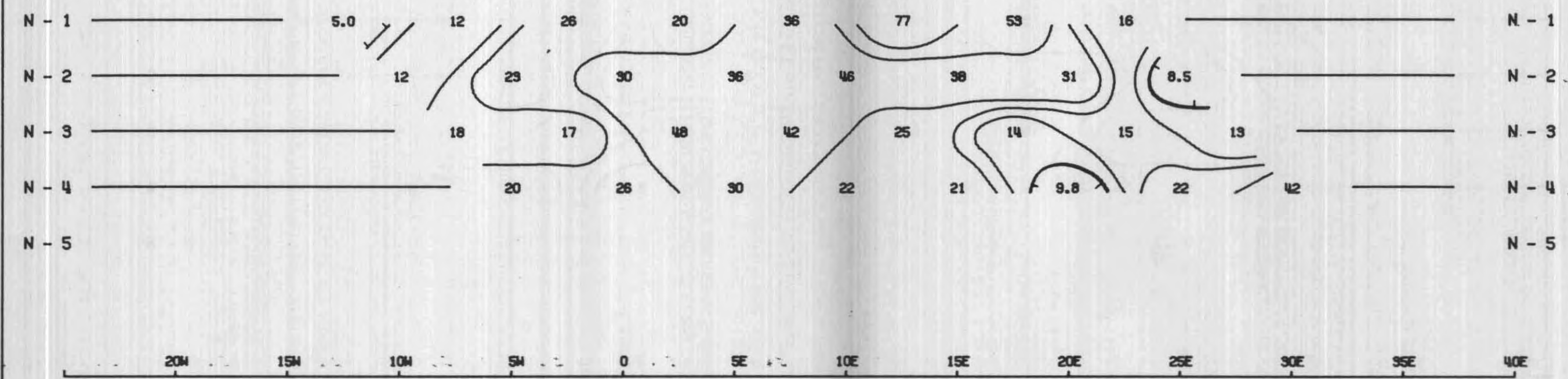

FREQUENCY EFFECT (APP.) IN %

FREQUENCY EFFECT (APP.) IN %

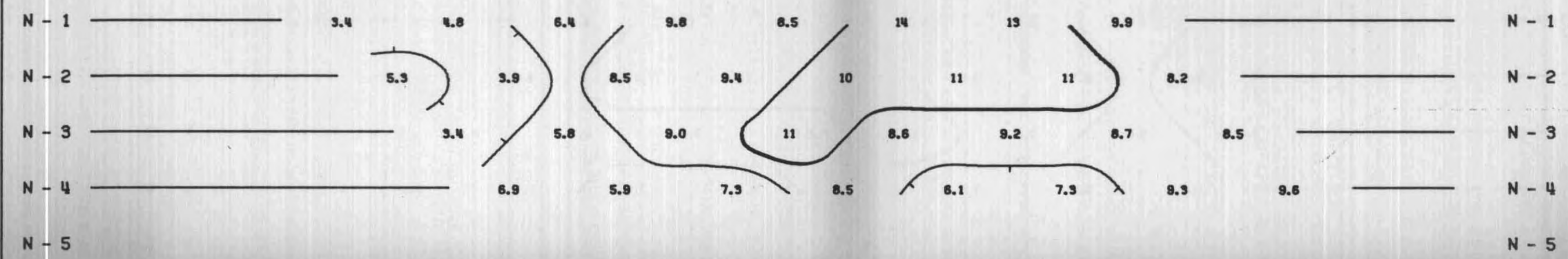

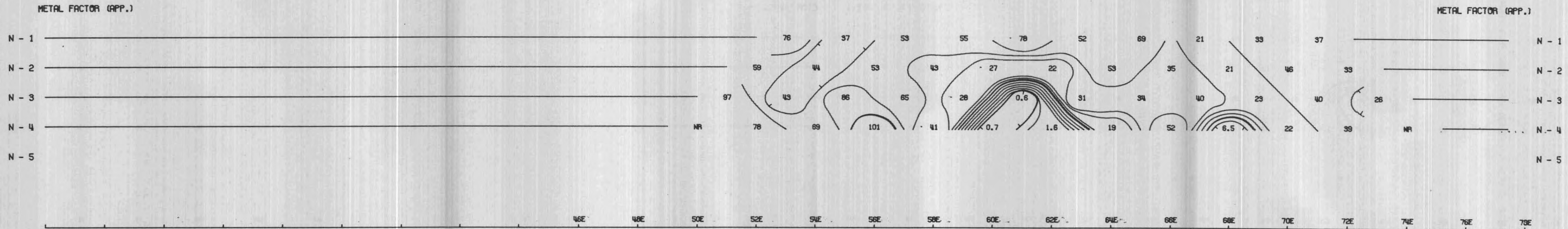
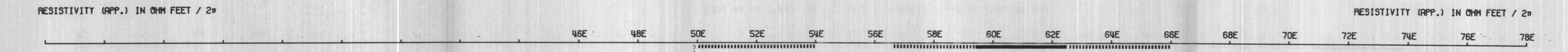
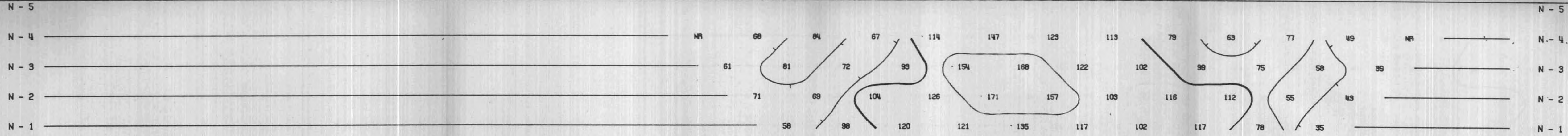

DWG. NO. - I.P. - 5563-12

BLUE ROCK MINING CORPORATION LTD.

BIG ONION PROSPECT
SMITHERS AREA
OMINECA M.D., B.C.

LINE NO. - 4N

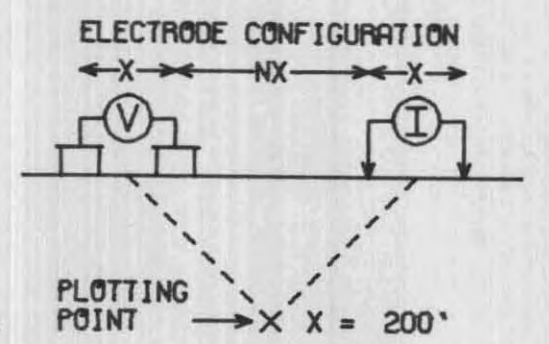

SURFACE PROJECTION OF ANOMALOUS ZONES
DEFINITE **————**
PROBABLE **————**
POSSIBLE **————**

FREQUENCIES: 0.31-5.0 CPS DATE SURVEYED: JUL 1970

APPROVED: *P. G. Kelly*
DATE: 10/14/70
PROFESSIONAL ENGINEER
Expiry Date: February 25, 1971

NOTE: CONTOURS AT LOGARITHMIC INTERVALS 1.-1.5-2.-3.-5.-7.5-10

McPHAR GEOPHYSICS

INDUCED POLARIZATION AND RESISTIVITY SURVEY

NOTE: THIS PLOT WAS PRODUCED WITH AN IBM 360/75 COMPUTER AND A CALCOMP PLOTTER

BLUE ROCK MINING CORPORATION LTD.

BIG ONION PROSPECT
SMITHERS AREA
OMINECA M.D., B.C.

LINE NO.- 4N

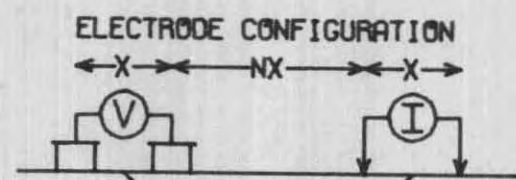

PLOTTING POINT X X = 500'

SURFACE PROJECTION OF ANOMALOUS ZONES
DEFINITE
PROBABLE
POSSIBLE

FREQUENCIES: 0.31-5.0 CPS

DATE SURVEYED: JUN 1970

APPROVED:
DATE: 10/21/70
ENGINEER

Expire Date: February 25, 1971

NOTE: CONTOURS AT LOGARITHMIC INTERVALS 1.-1.5-2.-3.-5.-7.5-10

McPHAR GEOPHYSICS

INDUCED POLARIZATION AND RESISTIVITY SURVEY

NOTE: THIS PLOT WAS PRODUCED WITH AN IBM 360/75 COMPUTER AND A CALCOMP PLOTTER

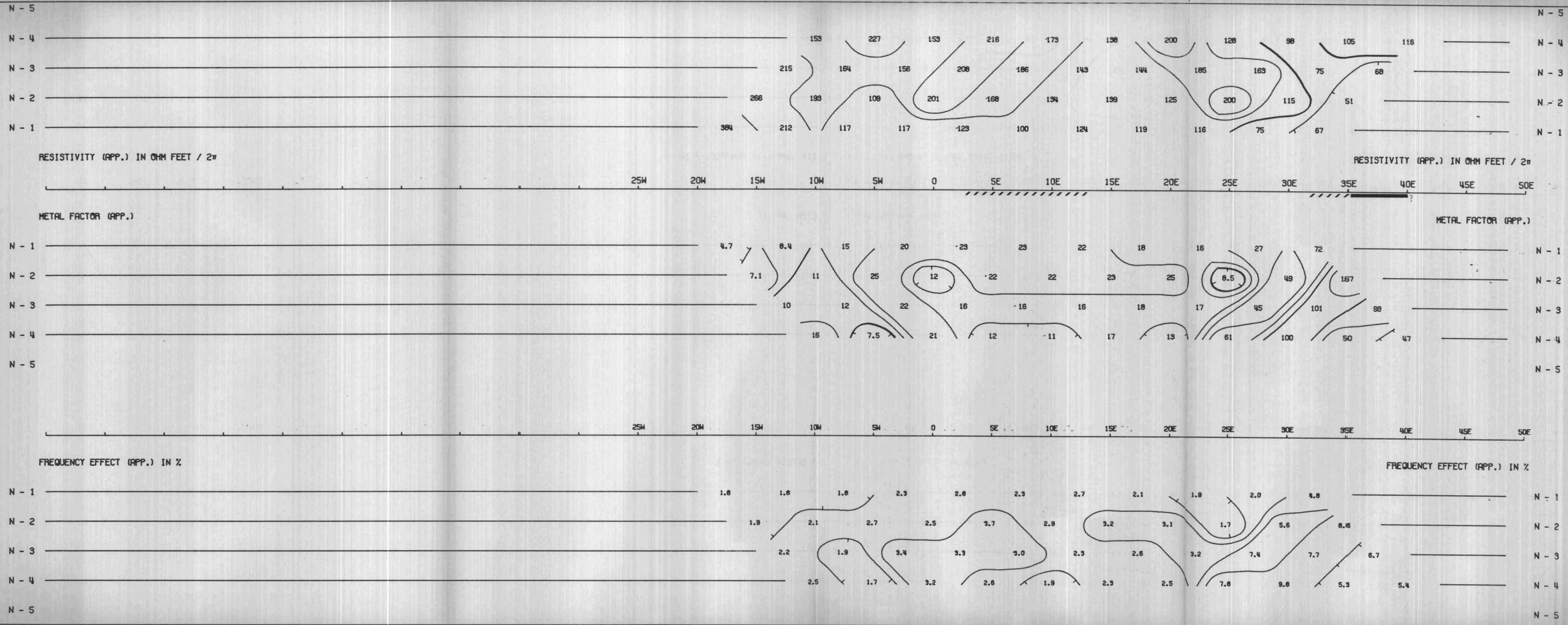

BLUE ROCK MINING CORPORATION LTD.

BIG ONION PROSPECT
SMITHERS AREA
QMINCEA M.D., B.C.

LINE NO. - 0

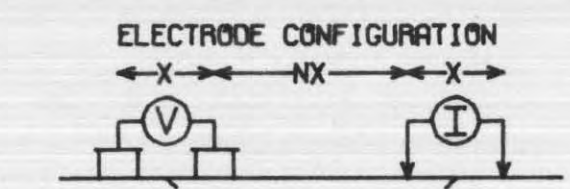

PLOTTING POINT X = 200'

SURFACE PROJECTION OF ANOMALOUS ZONES
DEFINITE
PROBABLE
POSSIBLE

FREQUENCIES: 0.31-5.0 CPS DATE SURVEYED: JUL 1970

APPROVED: ENGINEER

NOTE: CONTOURS AT LOGARITHMIC INTERVALS 1.-1.5-2.-3.-5.-7.5-10

DATE: 10/11/70

Expiry Date: February 25, 1971

McPHAR GEOPHYSICS

INDUCED POLARIZATION AND RESISTIVITY SURVEY

NOTE: THIS PLOT WAS PRODUCED WITH AN IBM 360/75 COMPUTER AND A CALCOMP PLOTTER

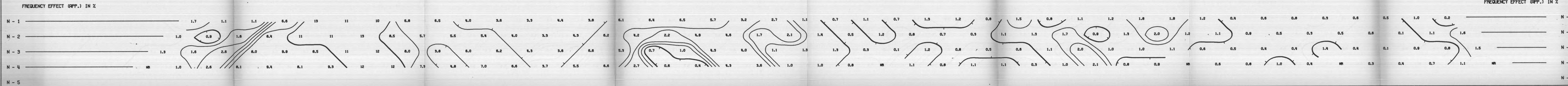
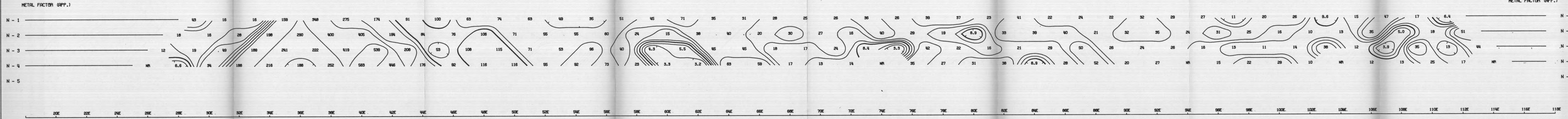
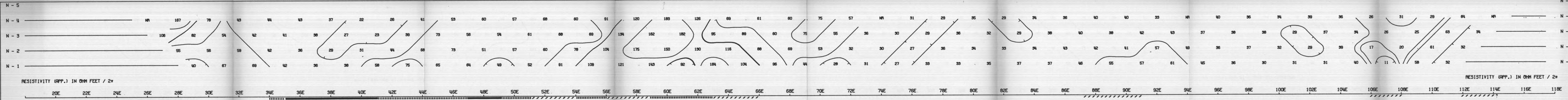

BLUE ROCK MINING CORPORATION LTD.

BIG ONION PROSPECT
SMITHERS AREA
OMINECA M.D., B.C.

LINE NO. - 45

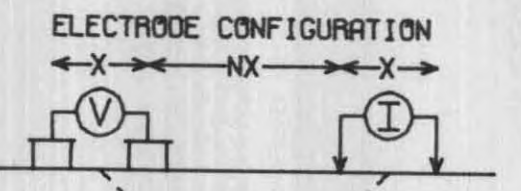

PLOTTING POINT X = 500'

SURFACE PROJECTION OF ANOMALOUS ZONES
DEFINITE
PROBABLE
POSSIBLE

FREQUENCIES: 0.31-5.0 CPS DATE SURVEYED: JUN 1970

APPROVED

NOTE: CONTOURS AT LOGARITHMIC INTERVALS 1.-1.5-2.-3.-5.-7.5-10

McPHAR GEOPHYSICS

INDUCED POLARIZATION AND RESISTIVITY SURVEY

NOTE: THIS PLOT WAS PRODUCED WITH AN IBM 360/75 COMPUTER AND A CALCOMP PLOTTER

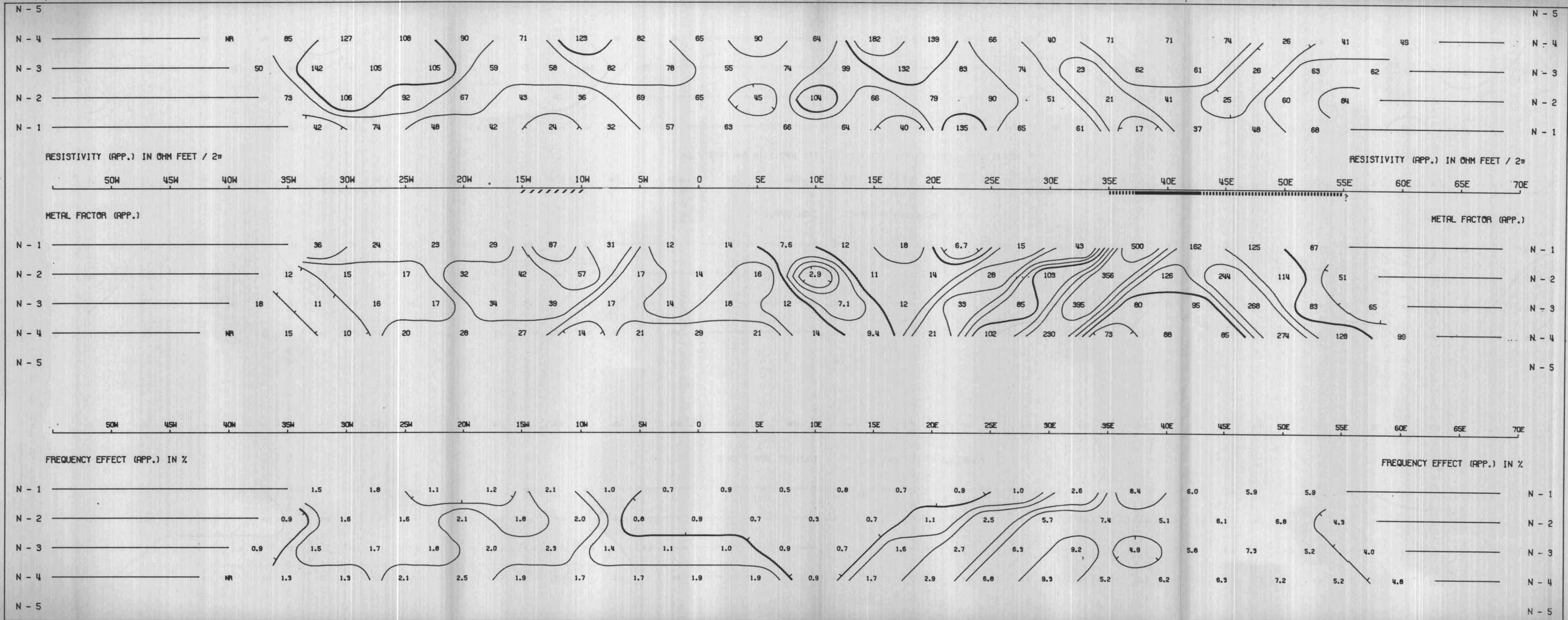

BLUE ROCK MINING CORPORATION LTD.

BIG ONION PROSPECT
SMITHERS AREA
OMINECA M.D., B.C.

LINE NO.- 45

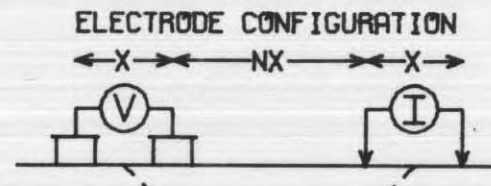

SURFACE PROJECTION OF ANOMALOUS ZONES
DEFINITE **————**
PROBABLE **—————**
POSSIBLE **////**

FREQUENCIES: 0.31-5.0 CPS

DATE SURVEYED: JUL 1970

APPROVED: *[Signature]*

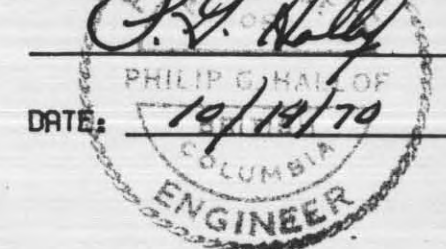

NOTE: CONTOURS AT LOGARITHMIC INTERVALS 1.-1.5-2.-3.-5.-7.5-10

McPHAR GEOPHYSICS

INDUCED POLARIZATION AND RESISTIVITY SURVEY

NOTE: THIS PLOT WAS PRODUCED WITH AN IBM 360/75 COMPUTER AND A CALCOMP PLOTTER

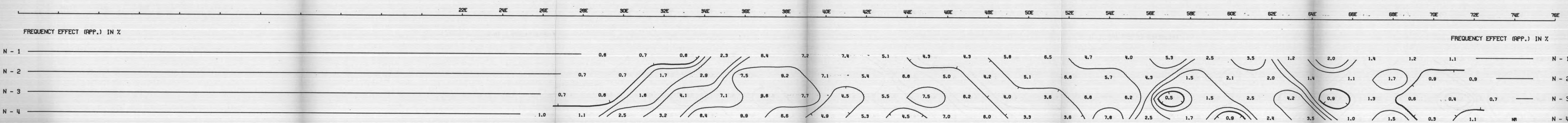
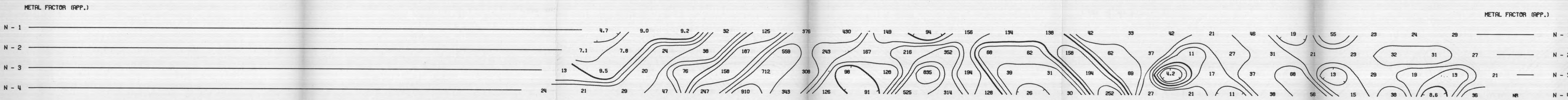
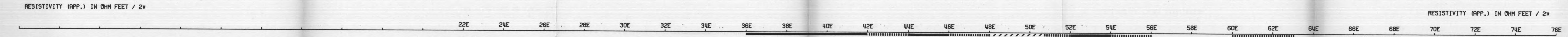
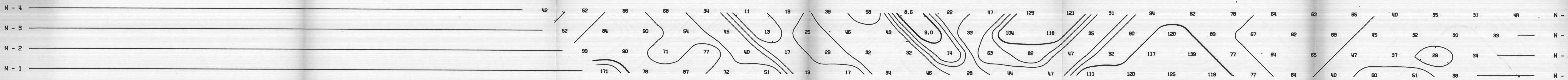

BLUE ROCK MINING CORPORATION LTD.

BIG ONION PROSPECT
SMITHERS AREA
OMINECA M.D., B.C.

LINE NO. - 85

ELECTRODE CONFIGURATION

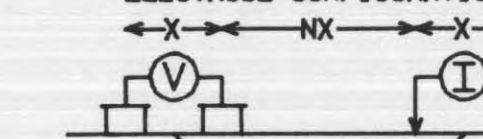

PLOTTING POINT X = 200'

SURFACE PROJECTION OF ANOMALOUS ZONES

DEFINITE
PROBABLE
POSSIBLE

FREQUENCIES: 0.31-5.0 CPS

DATE SUBMITTED: JUN 1970

APPROVED:

DATE: 12/19/70

ENGINEER

Expiry Date: February 25, 1971

NOTE: CONTOURS AT LOGARITHMIC INTERVALS 1.-1.5-2.-3.-5.-7.5-10

McPHAR GEOPHYSICS

INDUCED POLARIZATION AND RESISTIVITY SURVEY

NOTE: THIS PLOT WAS PRODUCED WITH AN IBM 360/75 COMPUTER AND A CALCOMP PLOTTER

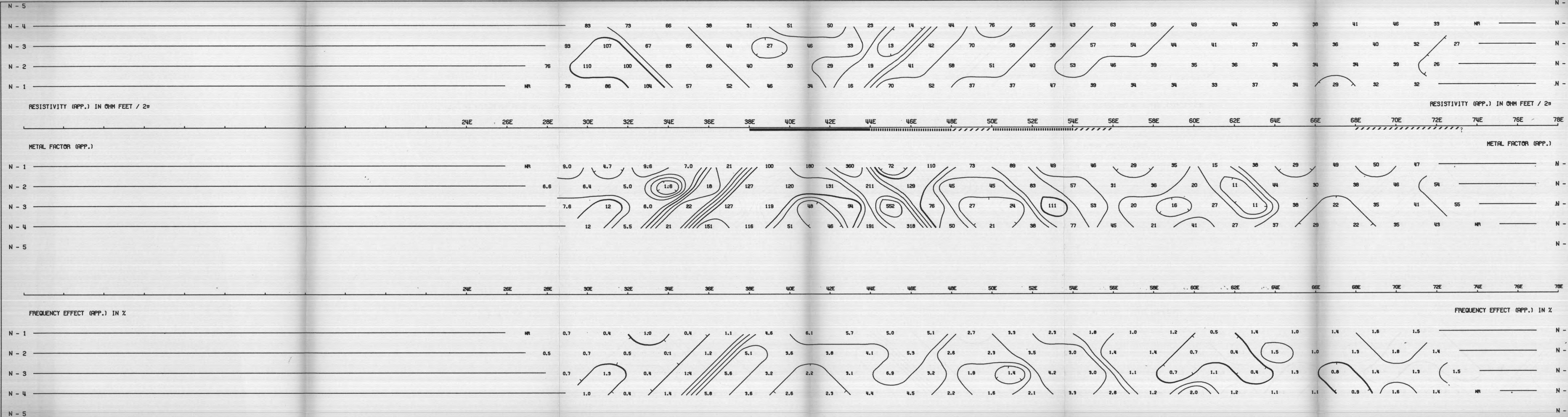

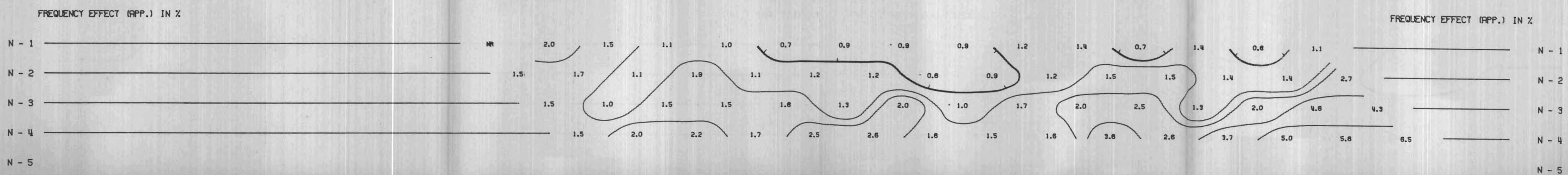
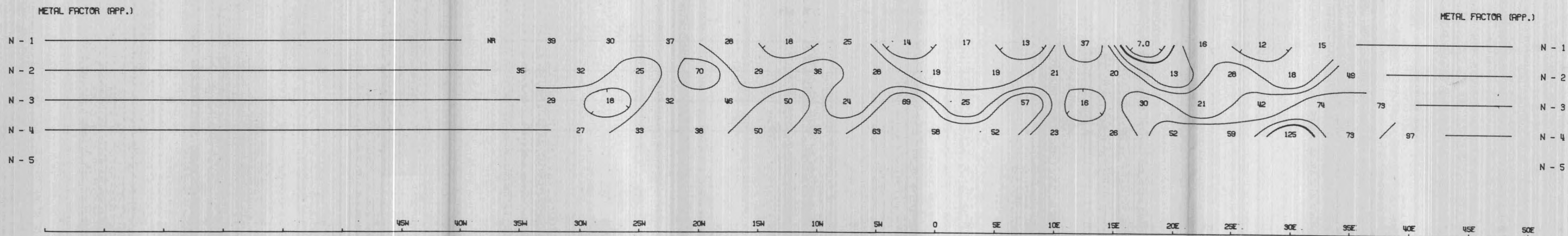
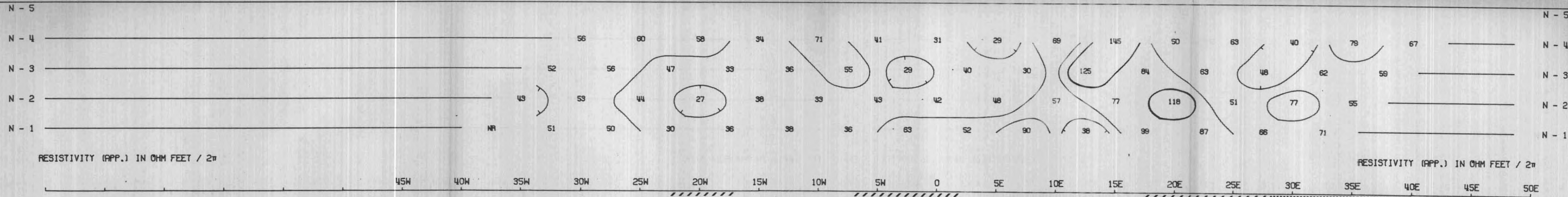

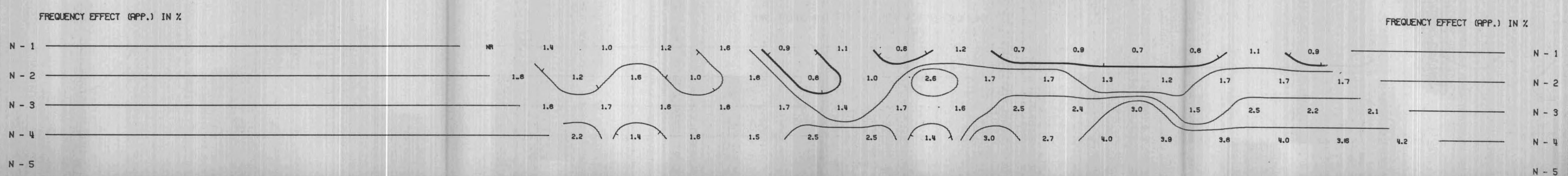
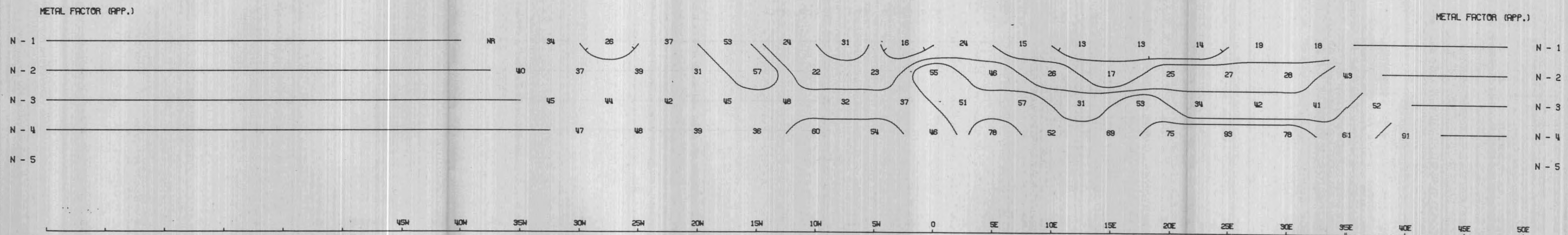
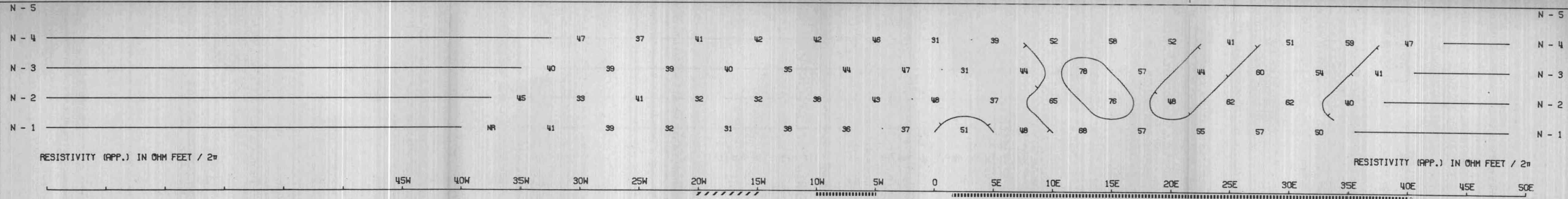

DWG. NO.- I.P.-5563-19

BLUE ROCK MINING CORPORATION LTD.

BIG ONION PROSPECT
SMITHERS AREA
OMINECA M.D., B.C.

LINE NO.- 20S

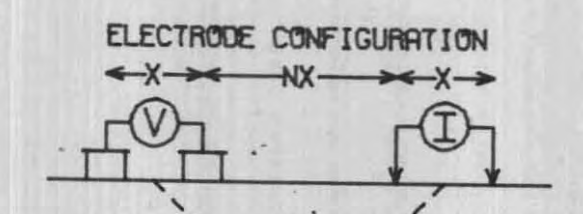

PLOTTING POINT X = 500'

SURFACE PROJECTION OF ANOMALOUS ZONES

DEFINITE **—————**

PROBABLE **—————**

POSSIBLE **—————**

FREQUENCIES: 0.31-5.0 CPS

DATE SURVEYED: JUN 1970

APPROVED: *R.H. Hally*

DATE: 10/14/70

PROFESSIONAL ENGINEER

Expiry Date: February 25, 1971

NOTE: CONTOURS AT LOGARITHMIC INTERVALS 1.-1.5-2.-3.-5.-7.5-10

McPHAR GEOPHYSICS

INDUCED POLARIZATION AND RESISTIVITY SURVEY

NOTE: THIS PLOT WAS PRODUCED WITH AN IBM 360/75 COMPUTER AND A CALCOMP PLOTTER

BLUE ROCK MINING CORPORATION LTD.

BIG ONION PROSPECT
SMITHERS AREA
OMINECA M.D., B.C.

LINE NO.- ROAD

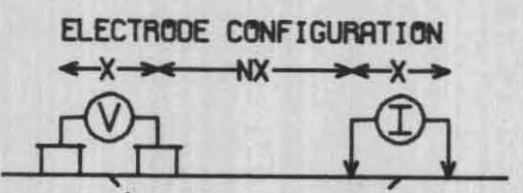

PLOTTING POINT X X = 200'

SURFACE PROJECTION OF ANOMALOUS ZONES

DEFINITE
PROBABLE
POSSIBLE

FREQUENCIES: 0.31-5.0 CPS

DATE SURVEYED: JUN 1970

APPROVED:

DATE: 10/14/70

ENGINEER

Expiry Date February 25, 1971

McPHAR GEOPHYSICS

INDUCED POLARIZATION AND RESISTIVITY SURVEY

NOTE: THIS PLOT WAS PRODUCED WITH AN IBM 360/75 COMPUTER AND A CALCOMP PLOTTER

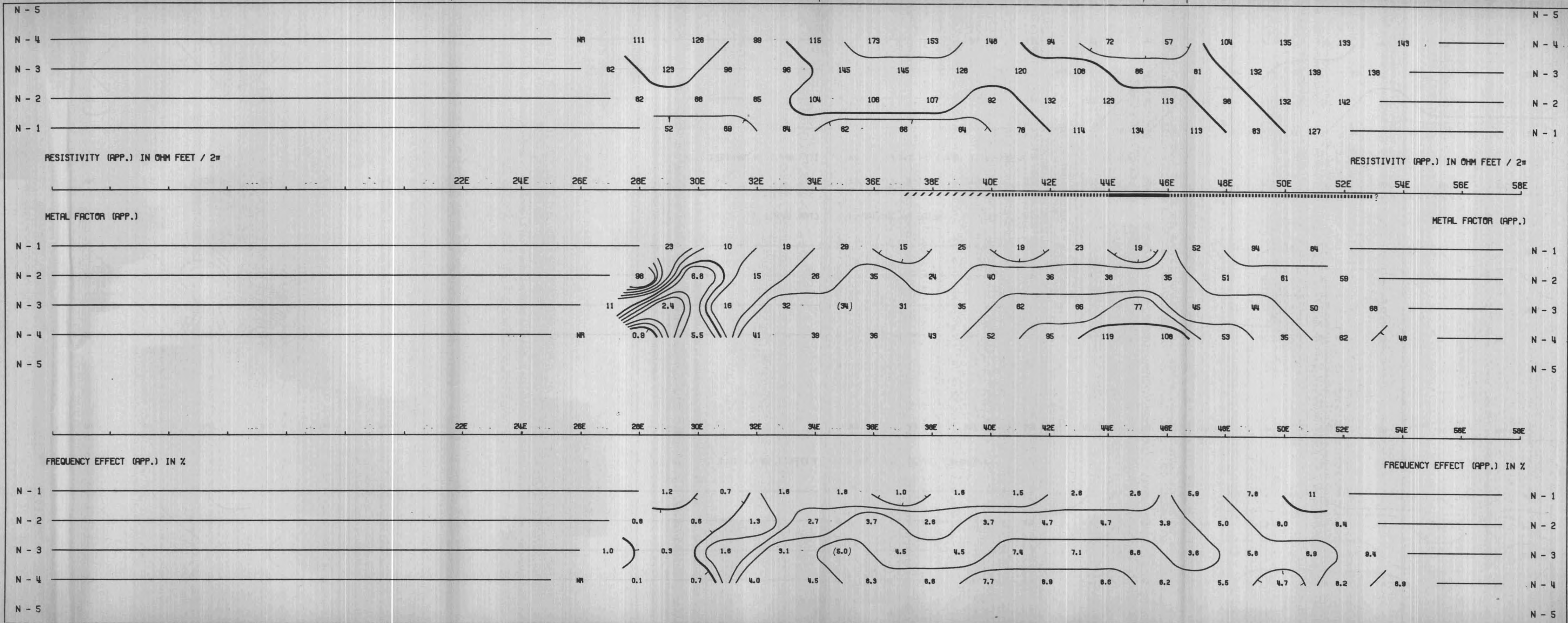

INTER OFFICE MEMO

CYPRUS EXPLORATION CORPORATION LTD.

VANCOUVER OFFICE

TO	REPLY	
	COMMENT	
RETURN TO		Date: November 16, 1970
NOV 19 1970		
1	<i>AM</i>	8
2	<i>1001</i>	6
3		7
4		8

To: C. A. MARK
From: J. B. P. SAWYER
Subject: McPhar I.P. Report on Big Onion

Ref: 758-CVL

I enclose for your information and file a copy of the report on induced polarization and resistivity survey of the Big Onion property, which was received today from McPhar.

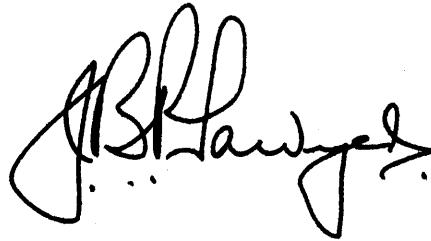

JBPS/aw

Enc: