

ALBERT F REEVE

680831

**MOUNT KLAPPAN ANTHRACITE PROJECT
STAGE II ASSESSMENT**

VOLUME I

SUMMARY

1987



**GULF CANADA CORPORATION
COAL DIVISION**

**MOUNT KLAPPAN ANTHRACITE PROJECT
STAGE II ASSESSMENT
VOLUME I - SUMMARY**

TABLE OF CONTENTS

	<u>Page</u>
HIGHLIGHTS	iv
1.0 INTRODUCTION	1-1
1.1 TRANSMITTAL STATEMENT	1-1
1.2 BACKGROUND	1-1
1.3 MINE DEVELOPMENT REVIEW PROCESS	1-4
1.4 STAGE II DOCUMENT ORGANIZATION	1-5
2.0 PROJECT DESCRIPTION AND DEVELOPMENT PLAN	2-1
2.1 SETTING AND LOCATION OF PROJECT	2-1
2.2 EXPLORATION SUMMARY	2-4
2.3 GEOLOGY AND ANTHRACITE RESOURCES	2-4
2.4 MINING	2-7
2.5 ANTHRACITE PREPARATION	2-10
2.6 OTHER PROJECT FACILITIES	2-12
3.0 ENVIRONMENTAL MANAGEMENT PROPOSALS	3-1
3.1 INTRODUCTION	3-1
3.2 WASTE MANAGEMENT PLANS	3-1
3.3 WATER MANAGEMENT PLAN	3-4
3.4 AIR QUALITY CONTROLS	3-5
3.5 RECLAMATION AND MONITORING	3-7
4.0 ENVIRONMENTAL IMPACTS AND MITIGATION	4-1
4.1 PREVIOUS STUDIES	4-1
4.2 ATMOSPHERIC ENVIRONMENT	4-1
4.3 AQUATIC ENVIRONMENT	4-5
4.4 TERRESTRIAL ENVIRONMENT	4-6

5.0 SOCIO-ECONOMIC IMPACTS	5-1
5.1 EMPLOYMENT AND POPULATION EFFECTS	5-1
5.2 ECONOMIC EFFECTS	5-3
5.3 IMPACT MANAGEMENT	5-4
6.0 OFF-SITE INFRASTRUCTURE	6-1
6.1 INTRODUCTION	6-1
6.2 ACCESS ROAD	6-1
6.3 PORT FACILITY	6-2
6.4 ELECTRICAL POWER SUPPLY	6-5

FIGURES	<u>Page</u>
2-1 Property Location	2-2
2-2 Principal Features	2-3
2-3 Stratigraphy	2-5
2-4 Mine Site Facilities Layout	2-9
2-5 Preparation Process Schematic	2-11
2-6 Project Development Schedule	2-15
4-1 Predicted Air Quality Impact	4-3
6-1 Access Route and Alternative	6-3
6-2 Port of Stewart	6-4
6-3 Ship Loading System	6-6

MOUNT KLAPPAN ANTHRACITE PROJECT
STAGE II ASSESSMENT
HIGHLIGHTS

The Mount Klappan Project

The proposed development includes a surface mine to extract raw anthracite, a preparation plant to wash the raw anthracite and produce a variety of clean anthracite products, and associated facilities such as a maintenance complex, office and dry facilities, water and power supply facilities and a camp complex for workforce accommodation. The development plan is predicated on the production of 1.5 million tonnes of clean anthracite annually for a minimum of 20 years. The product anthracite will be trucked to the deep sea port of Stewart for overseas shipment. Workers at the mine will reside in existing communities in the region and commute to the site by bus.

Anthracite

Coal which is geothermally heated and compressed becomes anthracite, a hard, brittle and quite pure form of carbon. It has never been produced in Canada and is physically and chemically quite distinct from the thermal and metallurgical coal produced by other Western Canadian coal mines. On a world-wide basis anthracite consumption, production and trade are increasing. The increase in trade is related to the decline of indigenous production in Western Europe and growing demand in Korea. The markets and uses for anthracite differ from the markets for Canada's other coals. Domestic heating in Europe, Korea and Japan is the primary use of anthracite. It is also used as industrial boiler fuel in Europe, a carbon source in specialty metal smelting, as a water purifying filter agent and for other specialty uses. The Mount Klappan anthracite can be processed to provide high quality and consistent anthracite products for all of these markets. The resource quantity in the mine area is estimated at more than 100 million tonnes, enough to sustain the mine far beyond the pre-planned 20 year production period while markets continue to be available and production remains viable.

The Mount Klappan Project Location

The proposed project is in the Mount Klappan coal license block owned by Gulf Canada Corporation approximately 150 kilometres northeast of Stewart and 930 kilometres north of Vancouver in the northwestern region of British Columbia. The property straddles the abandoned British Columbia Railway subgrade that runs between Prince George and Dease Lake. A new road between the property and Highway 37, the Stewart-Cassiar Highway, will be constructed to provide access to Stewart and other communities. This new road will provide the shortest practical truck haul route to the port in Stewart.

The Environmental Effects of the Project

- o Detailed assessment of power plant stack emissions from the proposed state of the art fluidized bed burner for waste anthracite indicates that environmental impacts will be negligible. The small scale of the plant and the emission control measures incorporated in its design will result in no appreciable diminishment of air quality in the area and emission concentrations would be far below the strictest environmental standards.
- o Most of the waterways of the Coal Licence Area will be largely unaffected by the mine operations. However, some of the primary drainage patterns in the immediate vicinity of the mine and plant area will be affected. Where sediment loading of the surface water is substantially increased, this will be managed by directing the run-off to sediment settling ponds before release to natural water courses. The discharges from these ponds will meet pollution control objectives and no significant effect on water quality downstream of the project is anticipated.
- o Effects on wildlife will be localized and minimal. The project area does not encompass any unique or intensely used habitat for sensitive wildlife species such as caribou or grizzly bear. No sensitive life cycle activities, critical use or large congregations of any species occurs in the project area.

- o No populations of rare plant species would be lost to the development and reclamation of disturbed areas upon completion of mining activity will initiate the revegetation process. Impacts on vegetation in the area from air emissions are predicted to be negligible.
- o Fisheries resources in the project area are virtually non-existent and the project will have negligible impact on fish and other aquatic life.
- o Project developments will cover an area of about 10 square kilometres which will be temporarily unavailable as wildlife habitat during the life of the project. The area is surrounded by wilderness in all directions and the alienation of this small area will have minimal impact.

The Socio-economic Effects of the Project

- o Capital costs for the project are expected to exceed \$250 million. Annual procurement requirements will be about \$50 million, \$10 million of which will be locally obtained.
- o Construction of the project will entail direct employment for a peak of about 975 workers. This will include a peak workforce of 450 workers for mine site development and access road construction will require an additional 525 workers at the peak.
- o Over 20 000 man-years of employment will be created by the project over the first 20 years of operation. Once operational, the project will employ close to 700 workers who will earn an average annual payroll of over \$27 million. Over 300 additional jobs are estimated to result from induced activities in local communities which will provide an average annual payroll of \$9 million.
- o Local residents are expected to fill about half of the direct and induced positions created by the project. People moving into the region will fill the remainder. Over 500 new households would be established in the region resulting in a population increase of about

1450 persons. It is estimated that about 75 percent of the population increase will occur in Stewart, but the new jobs created will be more evenly distributed through the northwest municipalities and existing service bases. Communities such as Dease Lake, Terrace, and Smithers will benefit through expansion of existing businesses and the initiation of new ones.

- o Provincial and local governments will receive increased revenues of over \$18 million annually due to income taxes, royalties, sales taxes and property taxes.
- o The project will provide long-term, stable economic returns to the region, an opportunity to diversify the economic base of the area and jobs in an area of chronic unemployment, especially for natives and young people. The impetus of economic development will also result in increased availability of social and commercial amenities in the area.
- o Gulf is considering establishing programs that would assist native people in enhancing their ability to access employment opportunities on the project.

1.0 INTRODUCTION

1.1 TRANSMITTAL STATEMENT

Gulf Canada Corporation is considering the development of an anthracite mining and processing operation at its Mount Klappan Coal License property in northwestern British Columbia. The company seeks and hereby requests Approval-in-Principle from the Government of British Columbia and offers this Stage II Environmental and Socio-Economic Assessment in support of this request.

This Stage II Assessment has been prepared in compliance with the Mine Development Guidelines and project review process prescribed by the Environment and Land Use Committee of the Government of British Columbia. The document provides details on the proposed development and describes the anticipated effects of the project on the natural environment, people and economy of the region. It follows from a Prospectus filed in February, 1984, and a Stage I Submission filed in June, 1985. Gulf volunteered with the filing of the Stage I Submission not to seek approval-in-principle until Stage II. This introductory volume presents a summation of the information contained in the other four volumes of this submission to the Mine Development Steering Committee.

1.2 BACKGROUND

Gulf Canada Corporation is a Canadian company engaged in a wide range of resource development and production activities in Canada and other countries. The Coal Division of the Corporation's Development Department is responsible for the advancement of the Mount Klappan Anthracite Project.

Six years of detailed exploration work at Gulf's Mount Klappan property has confirmed the presence of one of the non-communist world's largest deposits of high quality, surface mineable anthracite. The anthracite sector of the international coal market is a growth market with many of the traditional

INTRODUCTION

producing countries experiencing declining production. Mining and product preparation trials conducted at the property have proven that the Mount Klappan resource can provide a full slate of products ranging from the coarse, low ash anthracite favoured in Europe to the high ash briquetting anthracite that is needed in Korea.

Anthracite is a unique type of coal which has never been produced in Canada. Anthracite does not compete in markets with coking coal and thermal coal products from existing coal mines in British Columbia or Canada which produce coal for the steel-making and electrical power generation markets. Anthracite is a chemically and physically different material with a wide range of end-uses and markets such as home heating and specialty smelting in a number of European countries, titanium smelting and as boiler fuel in Canada, home heating briquettes in Korea and Japan, filtering in public water systems and other speciality uses.

The proposed Mount Klappan Anthracite Project would produce 1.5 million tonnes of product annually. Development of the mine and ancillary facilities at the site would involve an investment of over \$250 million. Construction of these facilities, which is scheduled to take approximately 18 months, would provide over 4500 person-months of employment. During this period, the residents and businesses in the region will begin to realize the substantial economic benefits the project will introduce to northern British Columbia.

Once operational, the mine will employ close to 700 workers in mining and anthracite transportation activities. When other associated employment is considered, it is estimated that in excess of 1000 permanent jobs will be created in the local region. This employment alone will introduce an average payroll to the area of over \$36 million per year. Company expenditures for goods and services will amount to another \$50 million annually. Much of this money will remain in the region to the benefit of the communities.

INTRODUCTION

Gulf has worked closely with the Provincial Government to examine various elements of the regional infrastructure such as road access, power supply and port improvements. These developments would offer additional employment opportunities and could encourage other economic development in the region. The project would also result in better utilization of municipal infrastructure in the area and would generate substantial tax and royalty revenues for local and provincial governments. Stewart, Dease Lake, Iskut and Telegraph Creek in particular will benefit from increased tax revenues.

Canada, as a whole, will benefit from improvements in the balance of trade with some of the nation's most important trading partners and the Federal Government will realize significant tax revenues as well. High unemployment among native people in the area has resulted in heavy reliance on the Federal Government for basic economic needs. Both the Government and native people can expect to benefit significantly from the job opportunities the project will provide.

Through the course of its project planning activities, Gulf has maintained an extensive program of liaison and consultation with local residents, regional planners, community leaders, native bands and many other special interest groups as well as Provincial Government authorities. Gulf has been greeted with a strong consensus of support for the project by local groups and has developed a range of local affairs policies in response to local concerns which are designed to insure that the regional effects of the project are positive in every way possible.

Gulf is confident that the Mount Klappan Anthracite Project can be developed with minimal impact on the environment of the region. Detailed environmental assessment studies have been conducted by the company for three years to insure that project planning incorporates all reasonable environmental protection measures such that the unique resources of the area, especially those within the Spatsizi Plateau Wilderness Park, will not be adversely affected.

In particular Gulf has selected, in the circulating fluidized bed combustor, the current best technology available for its possible thermal electric generating plant. This technology, coupled with a low-sulphur anthracite fuel, virtually eliminates sulphur dioxide and substantially reduces nitrous oxide emissions to levels that are significantly lower than the most stringent B.C. Pollution Control Objectives. There will be no contribution to acid rain.

Gulf is committed to continuation of its program of public consultation through the project planning and operation phases and intends to continue with its approach of responsibly addressing and resolving the environmental, social and economic concerns associated with the project.

1.3 MINE DEVELOPMENT REVIEW PROCESS

The British Columbia Mine Development Review Process has been prescribed by the Environmental and Land Use Committee of Cabinet as the procedure for effecting a single-path government review and assessment of mining developments proposed in the Province. The Mine Development Steering Committee is the body charged with managing the review process. All relevant government ministries and agencies are represented on this committee. The Coal Mine Development Guidelines are administered by the Steering Committee and provide potential developers with guidance on requirements for the review process.

Gulf initiated the government review process with the filing of a Prospectus for the project in 1984. This document described a conceptual plan for the development of the Mount Klappan property leading to the production of 3.5 million tonnes of anthracite product per year. A preliminary review of the potential impacts that could result from the development of the mine was undertaken. Gulf proceeded in 1984 with the socio-economic and environmental studies required for the development of the Stage I Submission.

The development concept of 3.5 million tonnes per year of anthracite product was substantially changed to 1.5 million tonnes of anthracite product per year following market assessment. The revised production level formed the basis for the Stage I Submission and this Stage II Submission. The Stage I Submission was filed in June, 1985.

Following a thorough review of the Stage I document, the Mine Development Steering Committee prepared and transmitted to Gulf detailed review comments and advisories as to information requirements for the Stage II submission. In particular, questions were raised concerning the environmental implications of the possible thermal electric power plant as this electrical power alternative was not dealt with in detail in Stage I. In the meantime, Gulf continued a number of environmental monitoring and impact assessment activities concurrent with ongoing exploration and feasibility work. Upon receipt of the comments of the Mine Development Steering Committee, some modifications to the existing environmental programs were made and some new activities, including a test burn of refuse anthracite in a fluidized bed burner, were launched in order to be responsive to the government's requirements.

These endeavours have culminated in this Stage II Assessment Report and request that the Environmental and Land Use Committee grant an approval-in-principle for the Mount Klappan Anthracite Project. Providing satisfactory long-term contracts can be secured with customers and subject to the approval of Gulf's Board of Directors, the Company is prepared to launch a Stage III program to secure all necessary permits from the government as soon as approval-in-principle is received.

1.4 STAGE II DOCUMENT ORGANIZATION

The Stage II Environmental and Socio-Economic Assessment for the Meunt Klappan Anthracite Project is presented in five separate volumes. The first is this volume which summarizes the key information contained in the other four volumes. It provides a brief description of the project and

discusses the principal effects of the project on the environment and economy of the region. Gulf's proposals for mitigating and managing these impacts are also outlined.

Volume II - Project Development Plan provides a detailed description of all aspects of the project which is divided into the major components of geology, mine plan, anthracite processing, infrastructure elements and environmental management features incorporated in the project plan. This volume contains much of the information developed in the course of Gulf's preliminary design and feasibility study efforts.

The results of a variety of studies addressing environmental impacts are reported in Volume III - Environmental Assessment. The material contained therein provides additional baseline data on the biophysical environment to supplement that which was provided in the Stage I submission as well as detailed investigations of air emissions, wildlife resources and water quality which were identified in the Stage I review comments as items requiring special emphasis. This volume also provides an inventory and assessment of heritage resources in the area.

Volume IV - Socio-Economic Assessment addresses the effects of the project on the regional population and economy. Employment and income projections are developed and the settlement patterns of in-migrant households are considered. Potential impacts on other economic activities and land uses in the region, along with the financial and social effects on individual communities in the area are also addressed. Volume V - Community Profiles is a companion volume to the Socio-Economic Assessment. The profiles provide updated baseline socio-economic data and records some of the local attitudes toward development for each community in the region.

2.0 PROJECT DESCRIPTION AND DEVELOPMENT PLAN

2.1 SETTING AND LOCATION OF PROJECT

The Mount Klappan property is comprised of about 50 000 hectares located 150 kilometres northeast of the ice-free port of Stewart in northwestern British Columbia. By air, the site is about 530 kilometres northwest of Prince George and 930 kilometres north of Vancouver. Figure 2-1 indicates the location of the property.

The property is located between elevations of about 1200 and 1800 metres above sea level and lies at the northern extremity of the Skeena Mountains. Property boundaries encompass several interconnected broad valleys with an indistinct height of land near the centre of the property. Within the mine area only the northern slope of Lost Ridge where the mine itself would be located, is steep. Other terrain in the area is quite gentle and provides easy surface access for mining. Figure 2-2 illustrates the principal features of the northwest region and the Mount Klappan coal licence block.

The tree line in the area is at about 1500 metres elevation. Most of the mine area is above the treeline in an area of alpine tundra, sparse grasses and barren rock. The mine area lies about 2 kilometres east of the upper reaches of the Little Klappan River which courses northwest away from the property.

The partially completed British Columbia Railway line between Prince George and Dease Lake runs through the licence area. Rail was laid to within 80 kilometres south of Mount Klappan before the project was abandoned. The railway subgrade was partially completed through and beyond the property as far north as the Stikine River. This subgrade presently provides road access to Mount Klappan from the Ealue Lake turnoff on Highway 37 near Iskut.

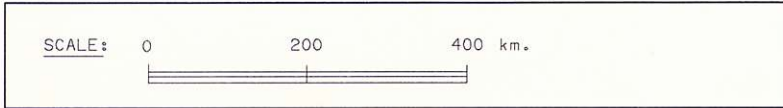

FIGURE 2-1
 GULF CANADA CORPORATION
 11/02/87



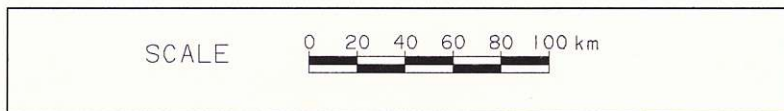
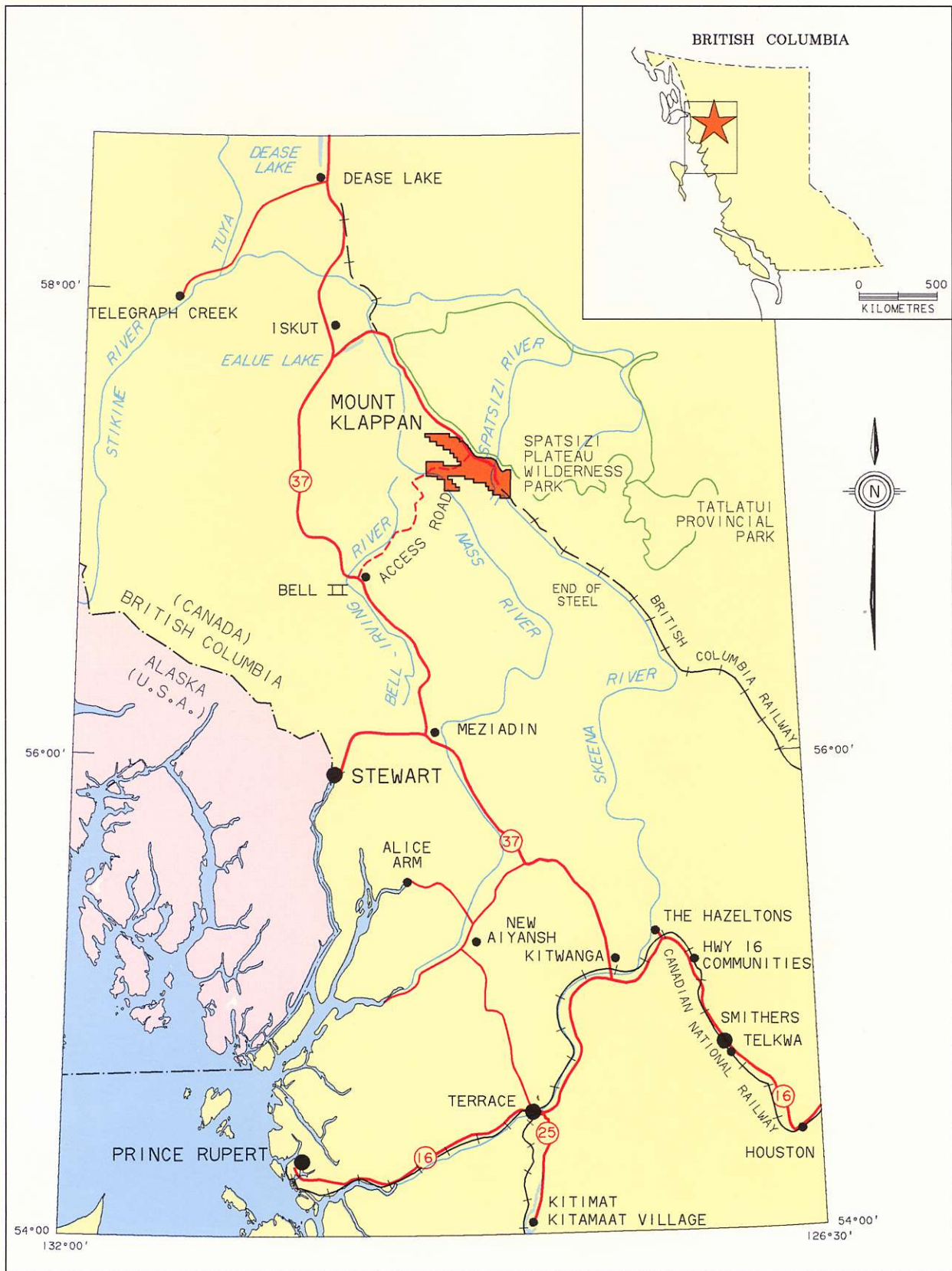

FIGURE 2-2
 GULF CANADA CORPORATION
 10/02/87



2.2 EXPLORATION SUMMARY

Anthracite was first discovered on what is now the Mount Klappan property in 1899 by Victor Dupont, an engineer working with the Canadian Department of Railways and Canals. Subsequent discoveries in the region attracted intermittent attention in the 1920's, 1950's and 1960's. Finally, in 1979, Gulf geologists became interested in the Mount Klappan area in the course of reconnaissance work along the upper Skeena River valley. By 1981, Gulf had acquired the coal licences for the property and had embarked on an extensive exploration program that has continued to this day.

In the more than six years of intensive work on the property, Gulf has advanced from regional investigations to trial mining, processing and shipment of test cargoes to potential overseas customers. To the end of 1986, close to 26 000 metres of diamond and rotary drilling in over 110 holes had been completed on the property. Over 2500 metres of mechanical and hand trenching had also been undertaken to investigate near surface outcrops of anthracite seams. Two adits have been driven into anthracite seams on Lost Ridge to extract bulk samples and a test pit has been opened on Lost Ridge for trial cargo mining. An exploration camp and pilot-scale anthracite processing plant have also been established on the property.

2.3 GEOLOGY AND ANTHRACITE RESOURCES

Four gradational sedimentary sequences have been identified on the Mount Klappan Anthracite Property. The area of the proposed mine on Lost Ridge contains the main anthracite-bearing rocks which Gulf geologists have designated as the Klappan sequence. Twenty potentially mineable anthracite seams ranging in thickness from 1 metre to 6.8 metres have been delineated in the sequence. The sediments were deposited in the Lower Cretaceous period under marine to coastal conditions. The stratigraphy consists of cyclic packages of sandstones, siltstones, mudstones, laterally discontinuous conglomerates and abundant anthracite seams. (See Figure 2-3 - Stratigraphy).

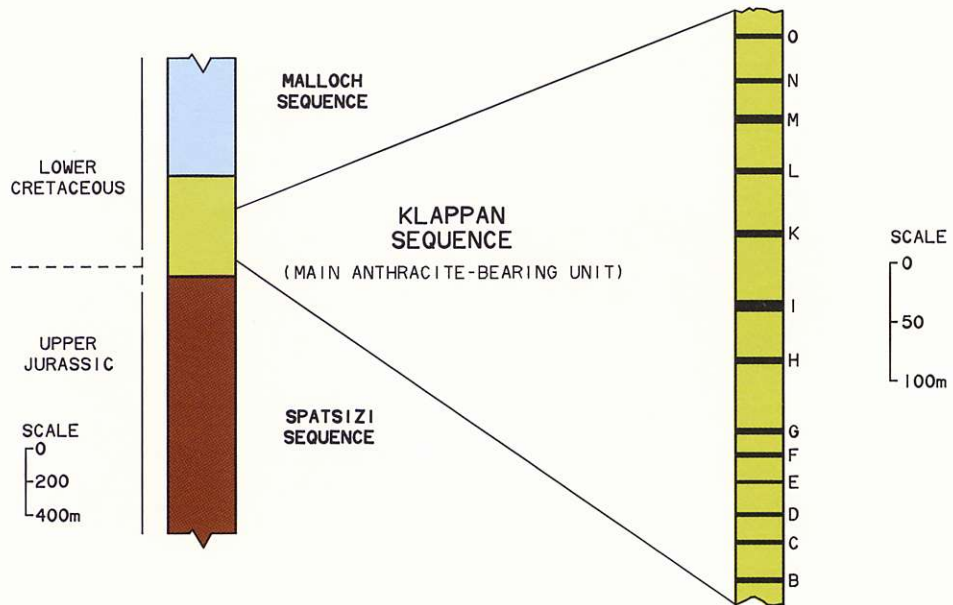
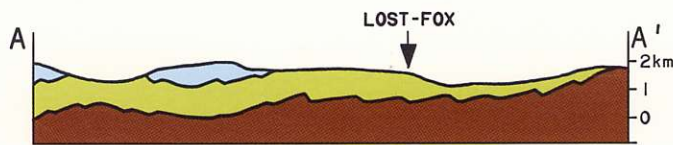
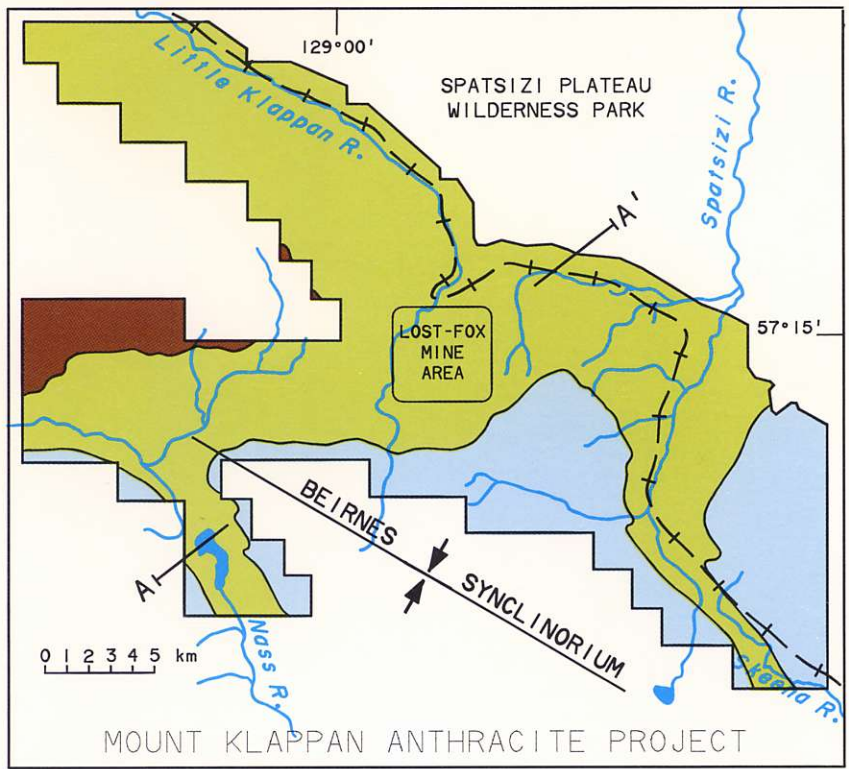

FIGURE 2-3
GULF CANADA CORPORATION
05/06/86



PROJECT DESCRIPTION AND DEVELOPMENT PLAN

Sampling of the coal seams has revealed them all to be uniformly of anthracite quality over extensive lateral distances. This indicates that the sedimentary sequence has been heated by a deep-seated and extensive source rather than by small, isolated intrusions or volcanic events. As a result, the anthracite quality is very consistent across the mining area, unlike many deposits, such as those found in many other parts of the world, where coal seams are sporadically intruded by igneous rocks and the seams are only locally heated to anthracite rank.

Folding in the anthracite bearing sequence is characterized by long, gentle southwesterly limbs and shorter, upright or overturned northeasterly limbs. The main folds within the deposit are 1 to 2 kilometres apart and provide very good locations for open pit mining where the fold crest approaches or outcrops on the surface. Lost Ridge is one of these locations. Faulting and disconformities in the anthracite bearing strata are relatively minor.

In the mine area, the twenty potentially mineable seams average a true thickness of about 2.4 metres and occur within about 450 metres of section in the Klappan Sequence strata. Over 100 million tonnes of mineable anthracite resource has been identified in the area of the proposed mine. It is clear from the exploration work conducted by Gulf that the resource extends well beyond the immediate area of the proposed mine.

The mine plan is predicated on producing about 30 million tonnes of anthracite product from the identified resource over an economic planning horizon of 20 years. Clearly, the resource can support operations for a much longer period. In the mine plan, nine of the potentially mineable seams would be released with Seams I and H accounting for 70 percent of the mineable reserve.

Washability testing has confirmed that the mine reserves can produce a wide range of anthracite products, differentiated by size and ash content, which range from coarse anthracite product with about 6 percent ash to finer products with approximately 25 percent ash. Raw anthracite has an average ash content of about 32 percent with a gross calorific value of

nearly 5400 calories per gram at a residual moisture level of 1.5 percent. Sulphur content of the raw anthracite averages a very low 0.47 percent.

2.4 MINING

Since several of the targetted anthracite seams outcrop on Lost Ridge, pre-production overburden stripping requirements are minimal. The mine will be opened up in three contiguous areas. The North area is on the northeast flank of Lost Ridge. It traces the outcrop of Seam H on the northeast side and follows this seam down dip to the southwest. The Central area is on the crest of the ridge and cuts along the strike of the overturned Seam I and continues to follow down dip of Seam H. The South area is the southwest part of the deposit and includes seams down through H. Nine seams contribute to the mine product of 30 million tonnes.

Stripping of overburden and interburden will be accomplished with 24.5 cubic metre capacity electric stripping shovels. The waste rock to be removed will be drilled and blasted prior to loading by the shovels into a fleet of 154 tonne capacity haul trucks. The waste material will be end-dumped from the trucks in the waste disposal area on the northwest side of the pit.

To minimize breakage, the anthracite seams will not be blasted. The exposed anthracite will be excavated and loaded into the 154 tonne capacity trucks by hydraulic backhoe excavators working from a series of 10 metre high benches in the pit. Anthracite excavation will take place in all three mine areas simultaneously but the north area will ultimately produce just over half of the 20 year mine reserve.

Initial stripping waste will be used primarily to construct haul roads. A number of in-pit ramps and roads will link with haul roads outside the pit which provide access to the waste disposal area to the northwest. Access to the disposal area will be available at several elevations and truck hauls will be planned such that the disposal site elevation and the waste loading elevation are as close to each other as practical.

PROJECT DESCRIPTION AND DEVELOPMENT PLAN

A haul road will be constructed for hauling run-of-mine anthracite from the pit area to the preparation plant complex. It will exit the pit area at the south perimeter and turn to the north to skirt Lost Ridge. All haul roads will be designed to specifications appropriate for safe operation of the 154 tonne trucks. Figure 2-4 indicates the arrangement of proposed mine site facilities.

Over the 20 year planning horizon, it is estimated that about 320 million bank cubic metres will be excavated from the pit in order to produce 1.5 million tonnes of clean product each year, or 30 million tonnes over the 20 years.

Major ancillary facilities associated with the mining operation are an office and dry complex northeast of the pit, a power distribution system, an explosives storage area north of the pit and an extensive array of water drainage and diversion facilities.

To the extent possible, all surface water runoff that is not crossing areas disturbed by mine development will be diverted away from disturbed areas and routed to lateral water courses by a system of diversion ditches and channels. All drainage from disturbed areas such as the mine, waste disposal area, roads and building sites will be captured in collection ditches and directed to settling ponds so that suspended sediments are removed from the water before discharge. This system will ensure that water quality in the project area will remain well within British Columbia Government objectives.

Precipitation in the area is moderate, averaging only about 400 mm per year. Snow accumulations in the winter are only from 1.0 to 1.5 metres. These modest volumes make mining operations relatively easy and drainage, erosion and sedimentation and pit dewatering issues present no significant problems. Much of the pit is either a stagnant or recharge area for groundwater so significant inflows are not expected.

MINE SITE FACILITIES LAYOUT

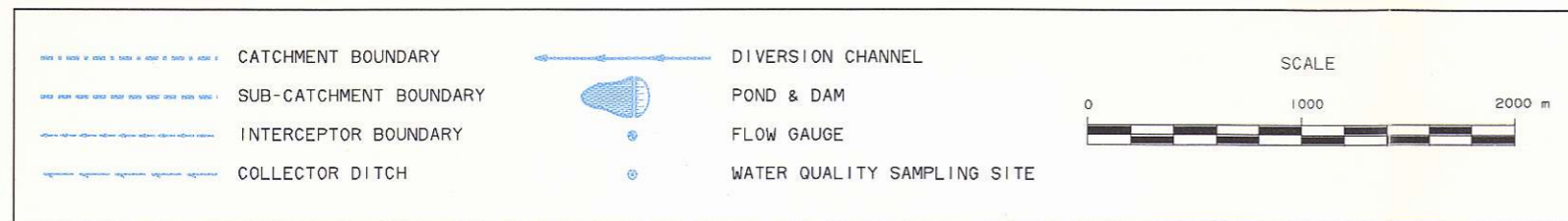
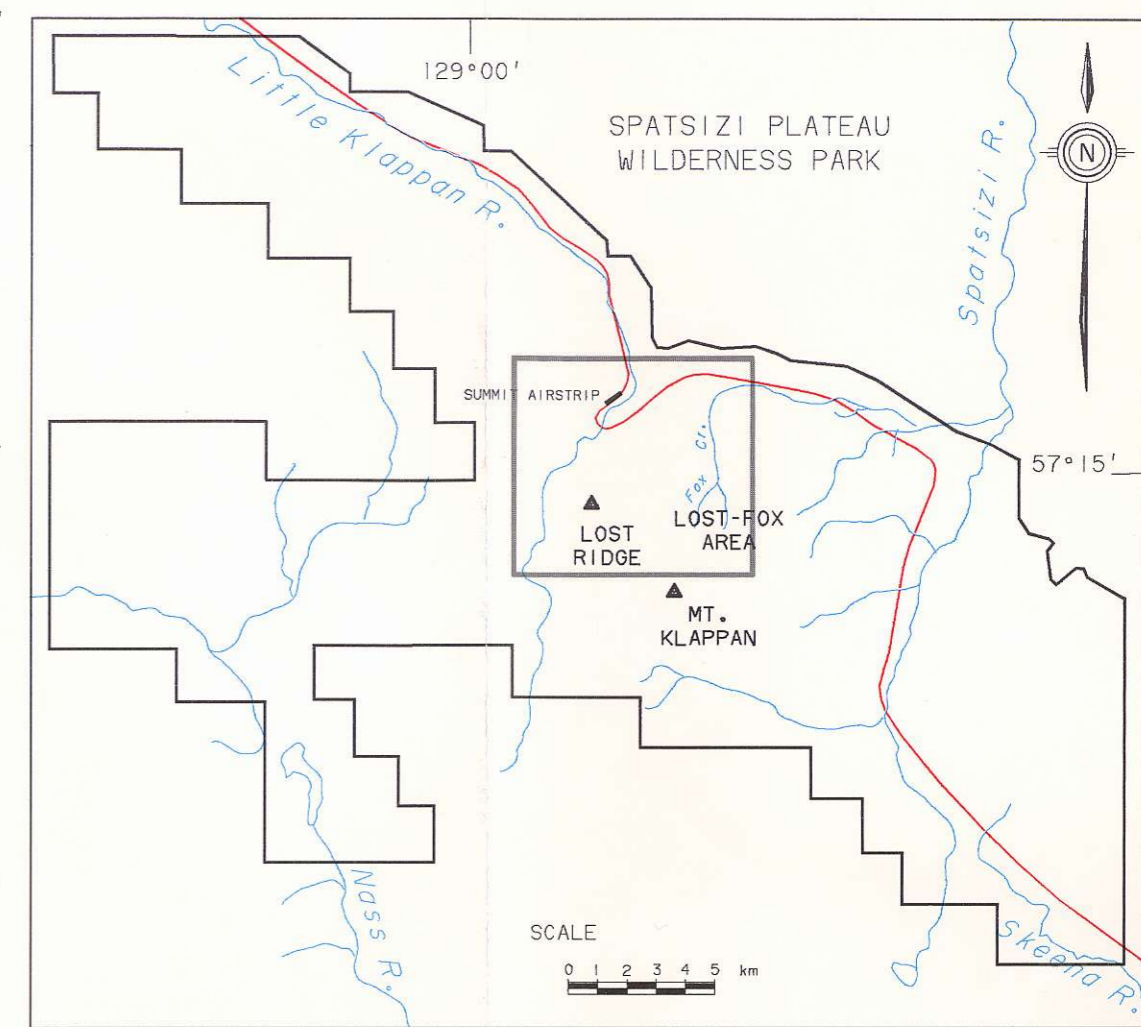
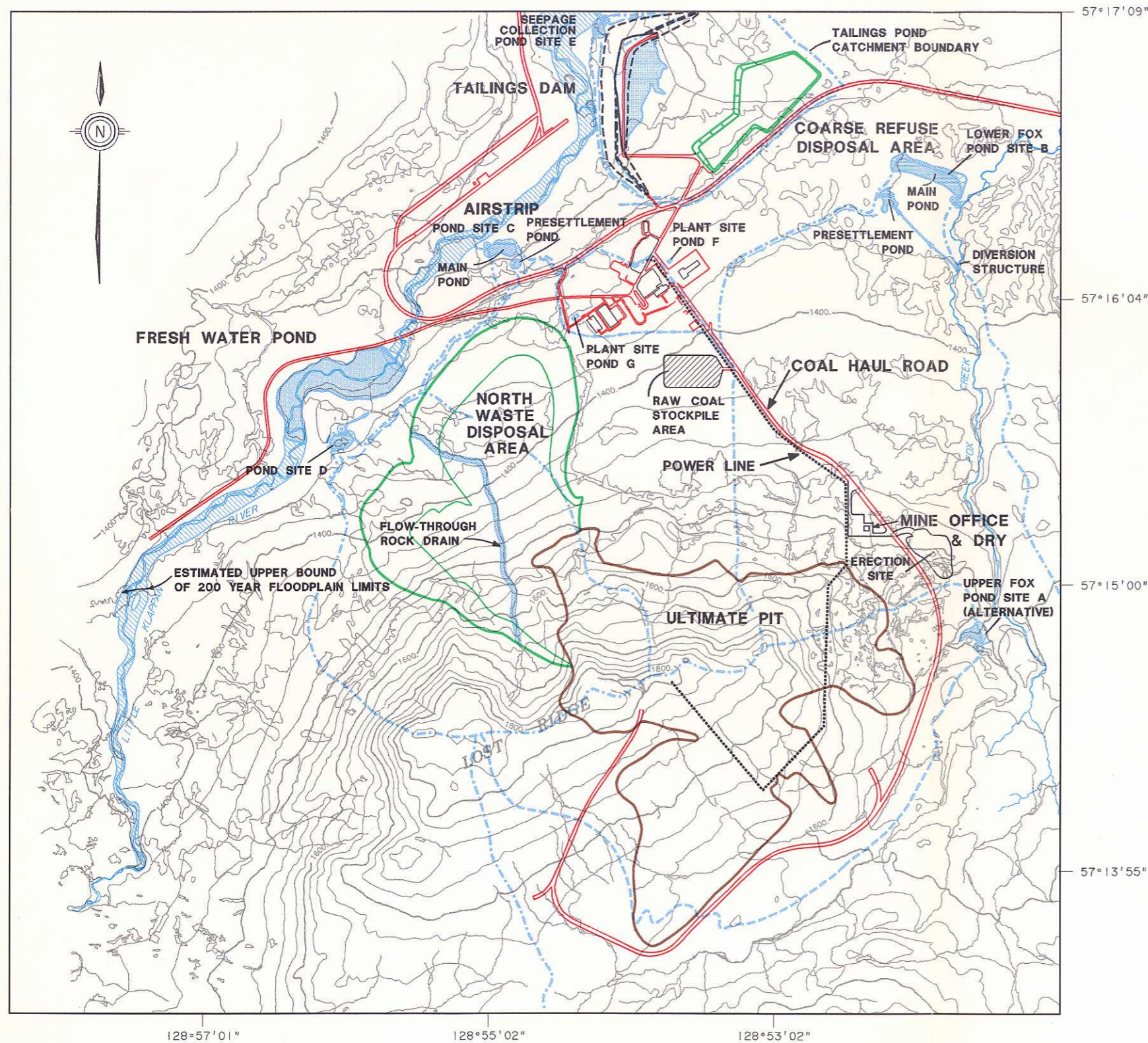

FIGURE 2-4
GULF CANADA CORPORATION
26/02/87



2.5 ANTHRACITE PREPARATION

Raw anthracite from the Mount Klappan mine can be washed to produce a variety of anthracite products ranging from fine anthracite of about 25 percent ash to coarse, low ash products. Relatively simple and proven washplant technology is incorporated in the preparation circuits which rely on heavy media separators to reduce the run-of-mine ash content. No chemical treatments are involved in the process and no chemically contaminated effluents will result. The basic preparation agent is simply water and magnetite (inert) which is continuously recovered and reused. Figure 2-5 schematically illustrates the preparation process.

Raw anthracite delivered to the preparation plant will be crushed and segregated into premium quality (coarse, low ash) and standard quality streams. Each will be handled separately throughout the preparation and transportation phases. A fine anthracite circuit will also be utilized for material passing the small size screening of both the premium and standard anthracite circuits. The anthracite cleaning circuits can be operated in parallel to simultaneously produce the same product or different products.

Each of the processing circuits for premium and standard anthracite will use heavy medium separators, one for coarse anthracite and one for medium sized anthracite. The fine anthracite circuit will employ classifying cyclones and centrifuges to recover the better quality portion of the fines.

Coarse refuse from the circuits will be mechanically dewatered and transported to a surge bin for truck loading. About 860 000 tonnes of this material will be generated each year. The same trucks that are used to haul raw anthracite to the plant will dispose of the preparation plant reject in a stockpile area north of the plant site. About 30 percent of this material will be used as construction material in the tailings dam. The disposal pile for the remainder lies within the catchment area of the tailings pond.

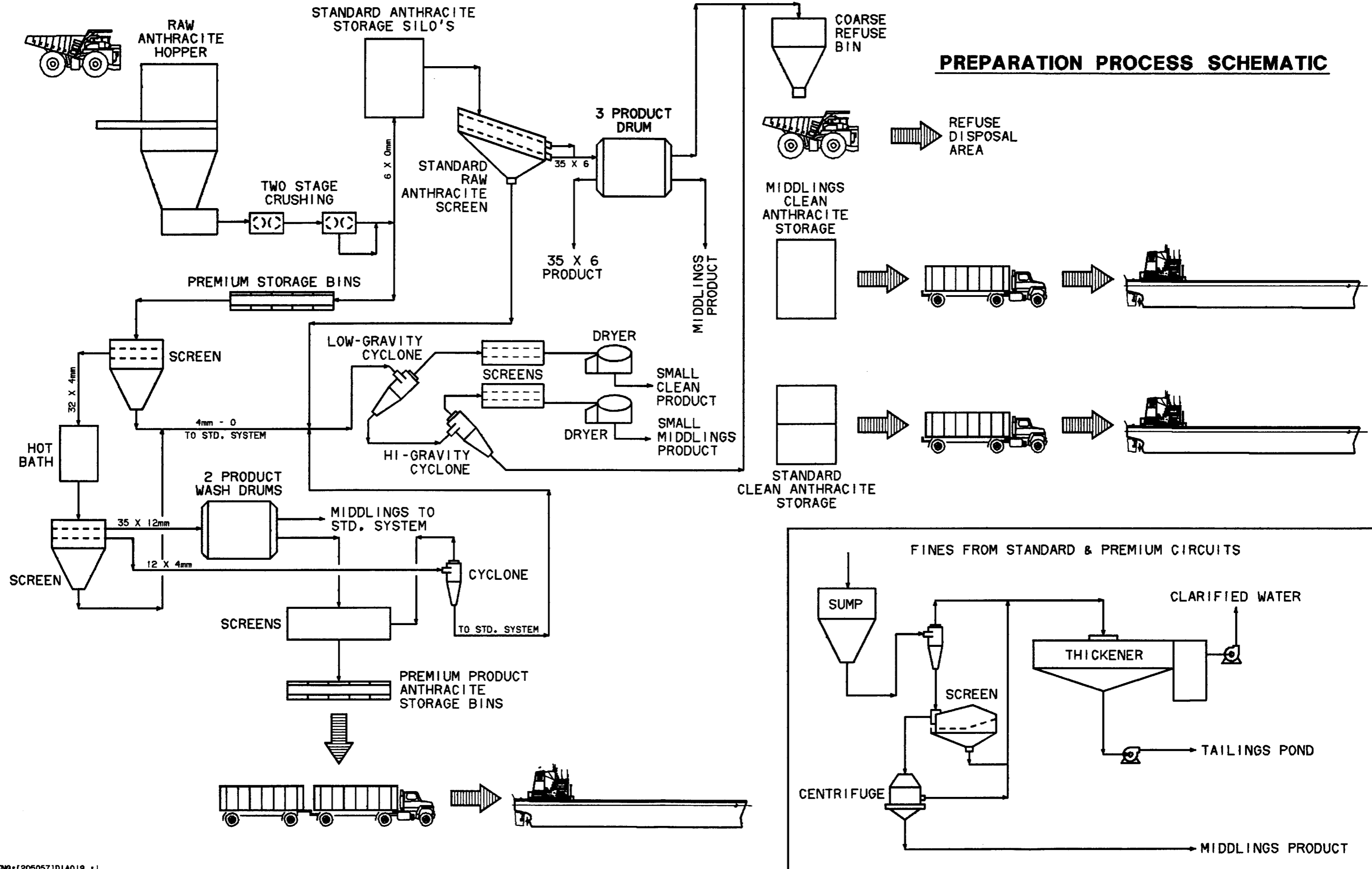

PROJECT DESCRIPTION AND DEVELOPMENT PLAN

The water and ultrafine particles left after extraction of anthracite products from the fine circuit will be directed to a tailings thickener vessel adjacent to the preparation plant. The thickener overflow will be recycled to the anthracite cleaning circuits. The underflow will be a slurry of about 30 percent solid material which will be discharged to the tailings pond. This discharge will incorporate about 117 000 tonnes of solids per year which will eventually settle to the bottom of the pond. The clean supernatant will then be decanted and recycled to the preparation plant.

Clean anthracite products are conveyed to storage to await loading on 45 tonne capacity haul trucks which would transport the anthracite to Stewart.

2.6 OTHER PROJECT FACILITIES

In addition to the mine and anthracite preparation plant, a number of ancillary and infrastructure facilities will be necessary to the operation. Several building complexes will house many of these necessary functions. The mine office and dry building near the mine has been mentioned previously. This structure will contain offices for mine management and engineering staff, as well as a locker room, shower and clean-up facilities for the mine work force.

The mine service complex would be located adjacent to the preparation plant and would contain repair and maintenance facilities for all mining equipment, warehousing and storage space, project administration offices, a laboratory and dry facilities for preparation plant and maintenance workers. Vehicle fuel storage tanks would also be located in this area.

A gatehouse complex would be located at the entrance to the site. This building would contain site security offices and annunciator controls for the fire alarm system. The first-aid infirmary would also be housed here along with the ambulance and fire truck garage.

PROJECT DESCRIPTION AND DEVELOPMENT PLAN

On-site accommodation would be provided in a 420 person camp facility which would also contain kitchen, dining and recreational facilities. Mine and plant workers will operate on 12 hour shift schedules and on a 7 day rotation basis. They will commute to the site from their homes in various communities in the region and will utilize the camp for room and board while on site.

Two alternate power sources are currently under consideration for the Mount Klappan project. One option entails construction by the British Columbia Hydro and Power Authority of a 280 kilometre, 138 kV transmission line from a point in the existing power grid at New Aiyansh, which is located 100 kilometres north of Terrace.

If this grid extension is not built, Gulf would construct a 15 MW thermal generating plant complex at Mount Klappan adjacent to the anthracite preparation plant. The power plant would provide the electric power and steam for anthracite processing and space heating by burning the coarse reject anthracite generated as a waste product from the preparation process.

Gulf has selected the best available, proven technology for meeting the dual objective of generating power from the high ash reject anthracite and minimizing potential air emissions from the boiler operation. Pilot scale testing of a circulating fluidized bed combustion (CFBC) system burning samples of Mount Klappan reject anthracite has shown the technology to be effective in meeting both objectives.

The air quality parameters of greatest concern with a thermal generating plant are sulphur dioxide, nitrogen oxides and particulates. The sulphur content of the fuel in this case is very low at about 0.4 percent. Calcium inherent to the ash content of the fuel reacts with the sulphur in the fluidized bed combustor removing most of it from the stack gases. The low operating temperatures of the CFBC boiler result in very low nitrogen oxide formation and a baghouse filtering system removes nearly all particulate matter from the flue gases.

PROJECT DESCRIPTION AND DEVELOPMENT PLAN

The resulting stack emission levels are well within British Columbia's strictest air pollution control objectives. Total sulphur dioxide emissions are .6 metric tonnes per day. This compares with, for example, 12 metric tonnes per day from the Alcan refinery in Kitimat or 30 metric tonnes per day of sulphur dioxide from a gas plant in Fort Nelson. The proposed Hat Creek Thermal Electric project would release 150 metric tonnes of sulphur dioxide daily to the atmosphere.

The power plant complex would house a fuel stockpile area and reclaim conveyor to feed the boiler unit. Steam produced by the boiler would drive a condensing 15 MW turbine generator which would be linked to control and switchgear and a substation to step the power down to 13.8 kV for distribution to the various site facilities. Bed and fly ash would be removed from the boiler and deposited in the coarse refuse disposal area.

Fresh water for anthracite processing, power plant operation, drinking, fire and domestic uses will be obtained from the Little Klappan River west of the plant site. Two alternatives are under consideration for the water supply. The first would involve a water reservoir dam which would contain about 1.2 million cubic metres or the equivalent of about one year's water demand. The other option entails excavation of gravel filled infiltration galleries adjacent to the river.

Development of the mine will also require construction of a new access road from Highway 37 at Bell-Irving II to the project area. This road will be utilized by the 40 tonne capacity haul trucks transporting anthracite to Stewart and for workforce commuting, mine re-supply and other access requirements. The access road, port, and alternative electrical power source are discussed further in Section 6.0.

Construction of the project facilities would require about 20 months. Assuming approval in mid-1987, product anthracite deliveries could commence in the spring of 1989. Figure 2-6 indicates the timing of development activities on a year by year basis.

**FIGURE 2-6
PROJECT DEVELOPMENT SCHEDULE**

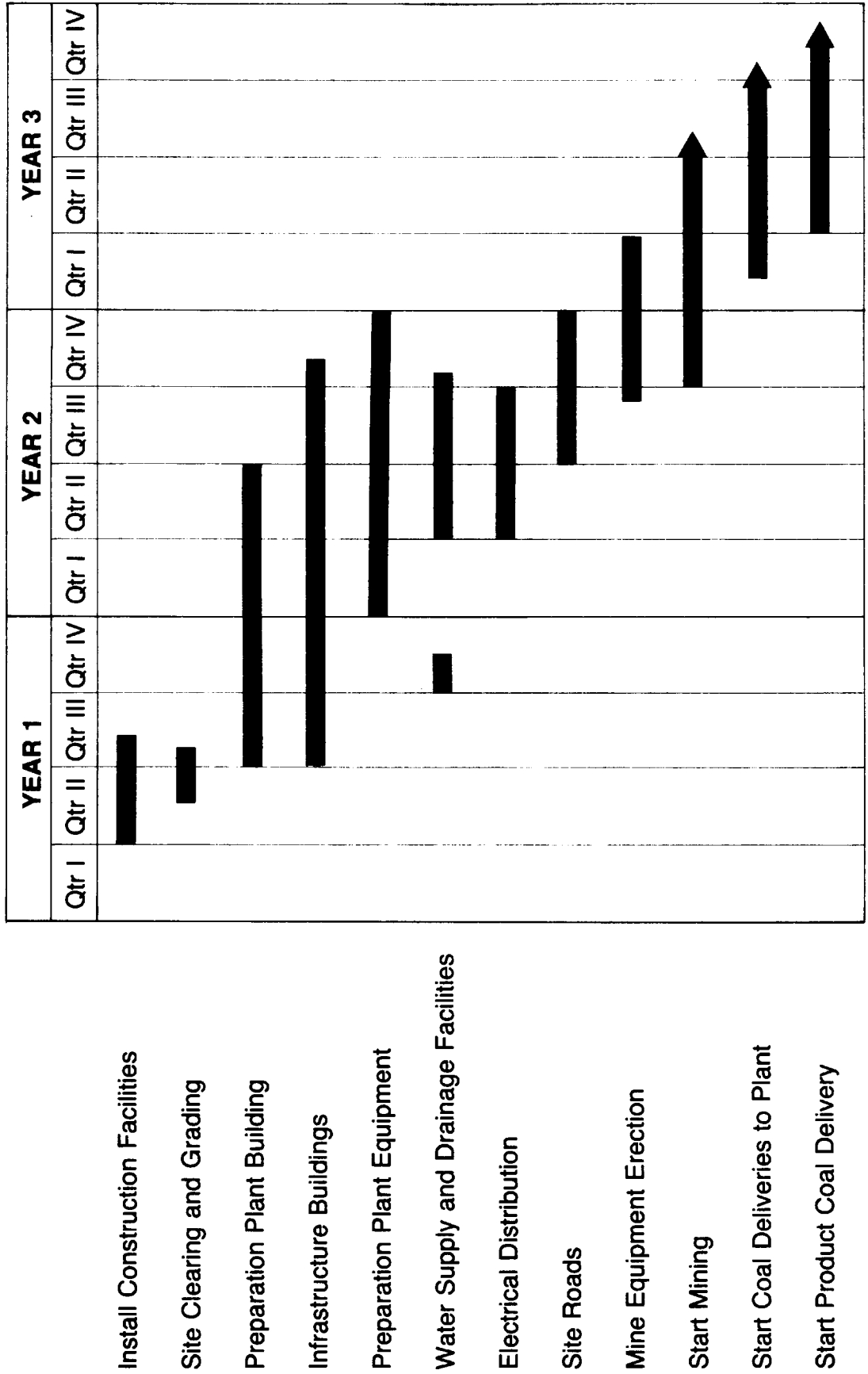

3.0 ENVIRONMENTAL MANAGEMENT PROPOSALS

3.1 INTRODUCTION

Gulf has incorporated a wide range of facilities, processes and policies in the Mount Klappan development plan which have as their primary function, the reduction or avoidance of potential environmental impacts. For a project such as that contemplated at Mount Klappan, effective approaches to waste handling and water management are key determinants of the environmental impact of the development. Contingency planning, reclamation planning and environmental monitoring are also critical to minimizing the environmental implications of the project.

If an on-site power generating plant is built, air quality control would be of significant importance.

3.2 WASTE MANAGEMENT PLANS

A careful inventory of all waste materials produced by the project has been conducted and sound methods for the disposal and/or treatment of each of these has been developed. The principal waste products directly associated with the mining and processing of anthracite are waste rock, tailings and reject anthracite. Each has been carefully evaluated to determine the possible effects on the environment.

Waste rock placed in the designated disposal area is the most significant product in terms of volume. After placement and compaction, it will occupy approximately 380 million cubic metres after 20 years of mine operation. Foundation and stability conditions in the disposal area are expected to be good. The area will be continuously monitored for evidence of movement or slumpage and unsafe groundwater pore pressures. Other than the alteration of the physical land form, there will be minimal potential for environmental degradation associated with waste rock disposal. An extensive series of laboratory tests has shown that there is an abundance of acid consuming

ENVIRONMENTAL MANAGEMENT PROPOSALS

rock in the waste material and there will be no danger of acid mine drainage being generated from this material.

Coarse refuse anthracite will amount to the second largest waste product in terms of volume at about 5.8 million cubic metres after 20 years. This material will be placed in an area of low permeability soils in the upper portion of the tailings impoundment area. Chemical analysis of the material indicates that metals in any leachate from the pile will be well below B.C. Pollution Control Objectives. The tailings pond will serve as a sediment trap to prevent suspended solids from the refuse disposal area entering the Little Klappan River. It is proposed that about 30 percent of the coarse refuse will be used as construction material in the tailings dam as it is expanded over the life of the project.

About 117 000 tonnes per year of solids will be discharged via slurry pipeline as tailings. The solids will consist primarily of fine mineral particles. The starter dam for the tailings impoundment will be about 860 metres long and 15 metres high and will be constructed primarily of impervious fill material excavated from within the tailings impoundment area. Coarse refuse from the wash plant would be used for subsequent dam raising which will eventually reach a height of 35 metres. Diversion ditches will be installed to divert all surface runoff from upslope of the tailings impoundment area and the coarse refuse pile to natural watercourses. Collection ditches and a seepage pond downstream of the dam will be constructed early to control suspended solids release to the Little Klappan River during tailings dam construction. After operations commence, dam seepage will be collected and will be recycled to the tailings pond. Clarified water from the tailings pond will be recycled to the wash plant to minimize the total amount of storage required, fresh water make-up requirements and the need to discharge water to the Little Klappan River. The tailings and reclaim pipelines will gravity drain to the pond in the event of a pump failure, process shutdown or line rupture.

Other materials requiring special handling are explosives components (ammonium nitrate and fuel oil), garbage, fuel, waste oil and miscellaneous

ENVIRONMENTAL MANAGEMENT PROPOSALS

chemicals. All will be handled according to accepted industry practice and in compliance with all government requirements. They will be stored in protected, bermed containment areas and spill contingency plans will be developed for handling any accidents. Waste oils and solvents will be reclaimed and shipped out for recycling. There will be no discharges of any of these materials. Explosives residuals in the waste rock will be of minor quantities and no problems of eutrophication or toxicity in area streams are anticipated.

Sewage will require disposal and treatment at three locations: the mine office and dry, the mine service complex and the camp. The latter two will utilize rotating biological contactor plants to treat the sewage and polishing lagoons to receive the treated discharge. The camp lagoon will discharge to the Little Klappan River while the overflow of the preparation plant lagoon will flow to the tailings pond. Both of these discharges will be of high quality meeting Waste Management Branch objectives. Sludge from the treatment plants will be periodically removed to the tailings pond. The mine office/dry will use an extended aeration treatment plant and discharge to a ground disposal field since it is distant from any suitable natural watercourse.

All solid waste and domestic garbage will be buried daily in the waste rock disposal area. No hazardous materials or toxic chemicals will be disposed of in the landfill. The garbage will be placed to avoid any flowing or standing water and will be continuously covered to deter bears and other animals from approaching the garbage disposal site.

If a power plant is constructed at Mount Klappan, bed and fly ash from the boiler unit would represent an additional waste product. Average ash production would be about 10 tonnes per hour or 1.75 million tonnes over 20 years. The ash will be sprayed with water to control dust and loaded on trucks for removal to the coarse refuse pile. The ash material compacts well and has self-cementing properties. It is naturally alkaline which will assist in the neutralization of acidic leachates, if any, in the coarse refuse. It would be placed in the pile so that it is encapsulated

ENVIRONMENTAL MANAGEMENT PROPOSALS

by the coarse refuse to control erosion or dusting. Chemically, the ash is benign and no water quality concerns are associated with the leaching of dissolved chemicals by precipitation or runoff.

3.3 WATER MANAGEMENT PLAN

Generally one of the most prominent environmental effects of a surface mining operation is increased sediment loads in surface water. Control of excessive concentrations of suspended solids is usually the key objective in water management planning. It is necessary to anticipate all changes to surface water quality and quantity associated with the project and to devise appropriate mitigative measures.

The water management plan developed for the Mount Klappan project will divert water draining undisturbed areas away from sites of proposed disturbance to reduce the quantity of water contaminated by sediments. Water draining from potential sediment sources in disturbed areas will be collected and directed to a suitable sediment pond site. After settlement of solids in the pond, the water can be discharged to area streams. Most of the project's plant and facility areas drain, after passing through sediment ponds, to the Little Klappan River. Much of the pit area, the mine office/ dry complex and haul road are in the Fox Creek-Didene Creek drainage area. Both of these water courses will be protected by the drainage and settlement pond system.

Where possible, each pond location will actually incorporate two ponds. A smaller presettlement pond will be constructed upstream of the larger main pond. The small pond will extend the life of the lower pond by trapping all bed load and the coarser suspended load. This small pond is designed for economical clean-out by conventional equipment. The large pond is designed to retain water for a sufficiently long time that most of the fine sediment load will settle even at extreme flood rates.

Three sediment pond sites have been located to collect all drainage from disturbed areas.

ENVIRONMENTAL MANAGEMENT PROPOSALS

Two of these are adjacent to the Little Klappan River and one controls the sediment load in Fox Creek. Two alternative locations are under consideration for the Fox Creek pond. Runoff collection ditches feed each of the ponds.

The tailings dam serves as a sediment trap for runoff from the area upslope of the site which includes the coarse refuse disposal area. Collector ditches and a seepage pond below the dam would be installed to trap water escaping from the tailings impoundment. Initially, water accumulated in the seepage pond will be returned to the tailings pond.

The system of diversion and collection channels and ditches as well as the sediment ponds will be designed such that discharges to the Little Klappan River and Fox Creek will meet the effluent quality objective of 50 mg/L of suspended solids. The only significant water losses that do not eventually end up in one of the sediment ponds or the tailings pond are evaporation losses from the power plant cooling tower, moisture in the anthracite products and coarse reject, various dust control spraying applications, and general evaporation.

The final area considered in the water management plan was a determination of whether or not any of the proposed facilities would encroach on the 200 year floodplain of the Little Klappan River. The analysis showed that all proposed facilities except the fresh water storage reservoir which must necessarily be located in the valley, and the access road crossing will be clear of the 200 year flood.

3.4 AIR QUALITY CONTROLS

Construction of the anthracite fired thermal generating plant at Mount Klappan would result in the release of air emissions in the form of flue gases and particulates. Typically, the emissions from a plant as small as that under consideration here would raise few concerns since the actual volume of emissions is exceedingly small. However, since the plant would be located in an area of pristine air quality and near the Spatsizi Plateau Wilderness Park, Gulf has incorporated a number of features in the power

plant design and operating procedures which will reduce emissions even further and ensure that the ambient concentrations of pollutants are only a small fraction of British Columbia's most stringent Pollution Control Objectives.

Sulphur dioxide and nitrogen oxides are the components of the flue gases which are of most concern. Operating features of the circulating fluidized bed combustor (CFBC) substantially control both. Fuel for the unit would be reject anthracite from the wash plant which is low in sulphur content and high in ash content. The ash contains substantial amounts of calcium. During combustion, this calcium reacts with the sulphur to form calcium sulphate, a dry, inert solid that is removed from the boiler as bed or fly ash. Limestone can be added to the combustion chamber to increase the available calcium and capture even more of the sulphur. Test burns of Mount Klappan anthracite have shown that 75 percent of the sulphur can be readily removed from the flue gases in this fashion which results in very low sulphur dioxide concentrations. The ambient mean annual and one hour concentrations for sulphur dioxide are 0.003 and 0.032 parts per million respectively. The most stringent B.C. Pollution Control Objectives are 0.01 and 0.17 parts per million. The maximum annual concentration is about 30 percent of the Control Objective. Concentrations of sulphur dioxide in the Spatsizi Plateau Wilderness Park will be about 3 percent or less of the objective and about one thousandth of the odour threshold.

Nitrogen oxide emissions increase with combustion temperatures. The CFBC unit at Mount Klappan would be operated at only about 850°C. Some burning efficiency is lost at the lower temperature but the nitrogen oxide emissions will be far below pollution control objectives as a result. The ambient mean annual and one hour averages for nitrogen oxides are 0.005 and 0.055 parts per million respectively. The most stringent B.C. Pollution Control Objectives are 0.04 and 0.16 parts per million.

Particulate emissions are controlled first by hot cyclones in the burner unit which remove the coarser particles from the flue gases and then by a baghouse which filters the finer particles. The proposed flue stack height

is 60 metres which will insure greater dispersion of stack emissions and correspondingly very low ground level concentrations in the Mount Klappan area. Particulate emissions will be 0.01 mg/kJ; this meets the B.C. Pollution Control Objective.

3.5 RECLAMATION AND MONITORING

Gulf has already commenced revegetation programs at the trial cargo pit and tailings dam which were developed in 1985. These experimental programs, as well as a series of test plots which have been planted to test various seed types, are being evaluated to identify appropriate revegetation procedures based on elevation, drainage and substrate conditions.

Upon completion of active mining in any area, including placement of waste rock, all disturbed areas will be revegetated to return the land to its similar present use primarily as wildlife habitat. These measures will also protect erodible surfaces and establish productive, self-sustaining ecosystems on the reclaimed land. Subsequently, the area will revert to its previous wilderness status and will again serve as habitat for a variety of small prey species, grazing areas for caribou and foraging territory for grizzly bear.

Throughout the life of the project a number of environmental monitoring programs are proposed which will be designed to detect, at the earliest possible stage, any unforeseen or more serious than expected environmental problems. Identification of these changes will allow timely application of remedial or mitigative actions. Three key areas will be scrutinized routinely. The water quality monitoring program will involve sampling of all effluent discharges from sediment ponds, sewage lagoons, the mine pit, tailings seepage and other sources to insure that waste management objectives are met in all cases. In addition, receiving water in the Little Klappan River and Fox Creek will be monitored to detect any changes in quality occurring in these streams.

ENVIRONMENTAL MANAGEMENT PROPOSALS

Should the anthracite fired electrical generating unit be in operation, air quality would also be monitored at a number of sites to determine sulphur dioxide concentrations and to identify any impacts on soil chemistry or lichen vegetation. Several stations would also be established to collect data on dustfall and particulate matter distribution.

A monitoring program will also track sightings and encounters with sensitive wildlife species in the area, primarily caribou and bear. Garbage will be buried daily to control bear encounters and the presence of bear or caribou on roads will be reported. If problems arise, appropriate mitigative measures will be taken.

4.0 ENVIRONMENTAL IMPACTS AND MITIGATION

4.1 PREVIOUS STUDIES

Earlier environmental impact investigations conducted by Gulf at Mount Klappan were reported in the Stage I Assessment which was submitted in 1985. These studies concluded that the Mount Klappan Anthracite Project would result in minimal environmental impacts. Water discharges from the project were expected to fully meet regulatory requirements and fishery resources in the area were accordingly expected to be unaffected. In addition, it was noted that fish presence in the project area is very limited because of unsuitable natural habitat.

It was also concluded that development of the mine would not result in the loss of any rare or unique vegetation populations. The area was found to not include any critical habitat for wildlife species and intense use or use at critical life cycle stages was not found.

Subsequent to the submission of Gulf's Stage I Assessment, several requirements for more detailed environmental assessment work were identified. As a result, exhaustive studies were conducted in 1985 and 1986 which form the basis for this Stage II impact assessment. During the same period, project planning has advanced from a conceptual stage to the present, much more detailed design. This assessment focuses on the most up to date project design.

4.2 ATMOSPHERIC ENVIRONMENT

The climate in the Mount Klappan area is in many ways ideal for mining. Rainfall and snowfall amounts are modest, temperatures are cool and winds are light. Extreme conditions are relatively rare and are not expected to cause any operational problems.

ENVIRONMENTAL IMPACTS AND MITIGATION

The principal source of potential impacts on the atmospheric environment associated with the Mount Klappan project would be power plant stack emissions. With the air quality control features inherent in the power plant design and operating procedures and based on the dispersion modelling studies conducted for the project, the effects on air quality will be negligible. There will also be negligible impact on soils or waters in the area.

Sulphur dioxide is the pollutant of greatest concern with power plant air emissions. The combination of low sulphur fuel, sulphur capture by calcium in the boiler and the small scale of the plant will result in only a very very modest of sulphur dioxide release. Nitrogen oxides emissions, which are a secondary concern, would be even less. These low levels of discharge are far below many common industrial process facilities operating in British Columbia.

The ambient annual average concentrations of sulphur dioxide will for the most part be only a small fraction of British Columbia's strictest air quality objectives and will probably be undetectable in most areas. Even in the isolated, small zone of about 1 square kilometre where the maximum annual concentration is predicted, the sulphur dioxide levels will only be about 30 percent of the control objective. Concentrations in the Spatsizi Plateau Wilderness Park will be about 3 percent of the objective or less (see Figure 4-1).

Worst case 1-hour concentrations of sulphur dioxide were also studied. This would occur when a very strong inversion and very light winds persist such that the power plant plume spreads to fill the valley in a thin, concentrated band. The peak concentrations would occur where this band comes into contact with the valley walls. Analysis of the meteorological data indicates that the frequency of events when all the necessary conditions are met for sufficient time to allow the plume to fill the valley is exceedingly rare. Nevertheless, if the phenomenon should occur, the concentration is still predicted to be less than one-fifth of the most stringent 1-hour maximum pollution control objective. The ambient annual

PREDICTED AIR QUALITY IMPACTS

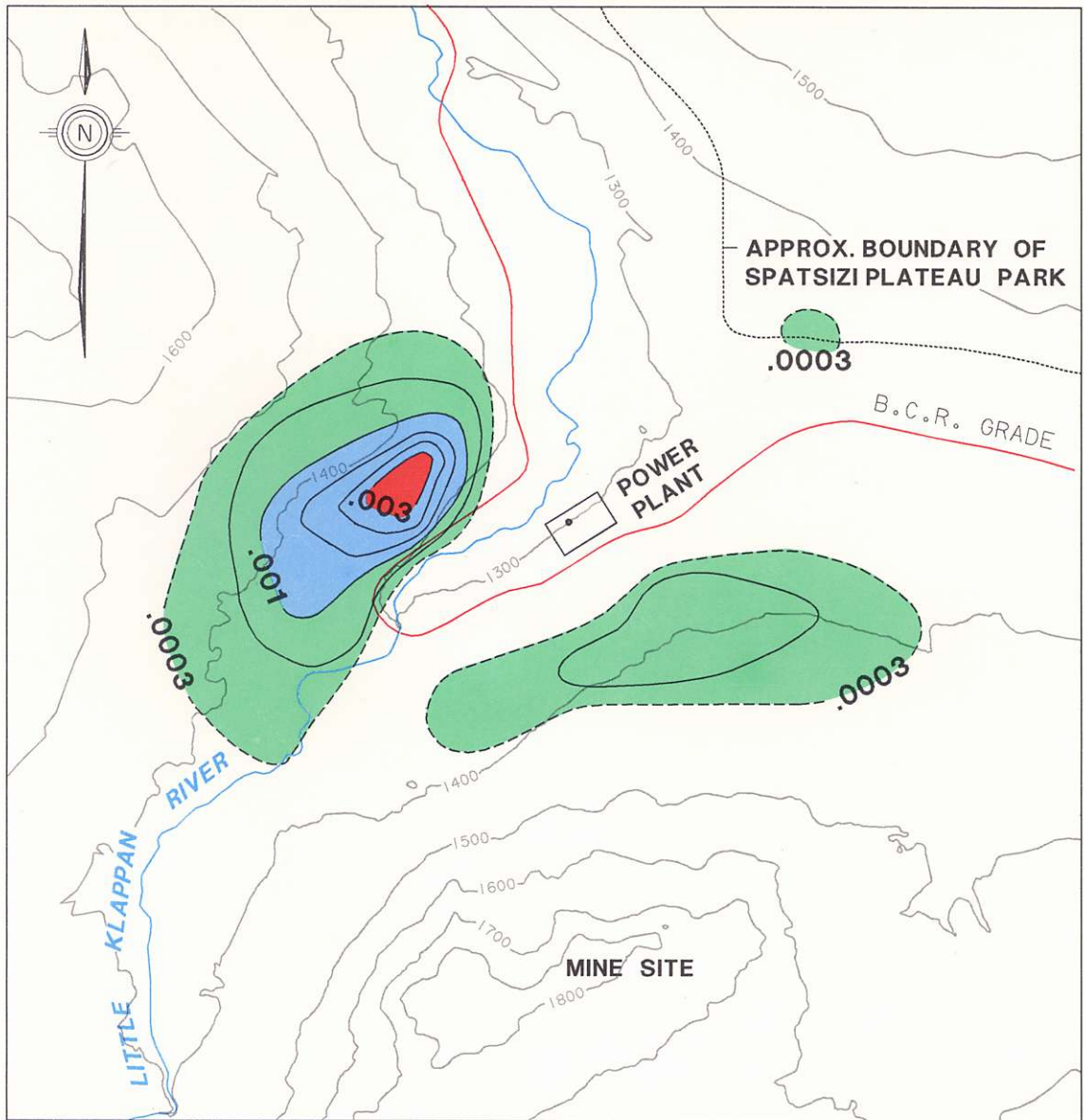

- > .003 ppm
- < .003 ppm & > .001 ppm
- < .001 ppm & > .0003 ppm

NOTE:
 ALL OTHER AREAS LESS THAN .0003 ppmv
 B.C. POLLUTION CONTROL LEVEL A OBJECTIVE .0100 ppmv



FIGURE 4-1
 GULF CANADA CORPORATION
 04/03/87



ENVIRONMENTAL IMPACTS AND MITIGATION

average and 1-hour concentrations for sulphur dioxide, nitrogen oxides and carbon monoxide are summarized below.

Maximum Ambient Concentrations - Power Plant Emissions

Parameter	Unit	B.C. Pollution Control Objective	Mount Klappan Maximum Ambient Concentration
<u>Sulphur Dioxide</u>			
Annual Average	ppmv*	0.01 - 0.03	0.003
1 hr. Maximum	ppmv	0.17 - 0.34	0.032
<u>Nitrogen Oxide</u>			
Annual Average	ppmv	0.04**	0.005
1 hr. Maximum	ppmv	0.16 - 0.4	0.055
<u>Carbon Monoxide</u>			
Annual Average	ppmv	-	0.002
1 hr. Maximum	ppmv	5.7 - 11.2	0.033

* Parts per million volumetric

** Federal Standard - Maximum Desirable

Sulphur deposition on soil and surface waters was also modelled. Due to the very small amount of sulphur released from the power plant, deposition rates were also found to be very low and in the order of less than 5.5 kg per hectare per annum. The impact on soils and water chemistry or vegetation in the area will be negligible.

Trace metal emissions were found also to be very low. The impact on the ambient air quality will be negligible.

4.3 AQUATIC ENVIRONMENT

Water quality in the Mount Klappan area is good and discharges to the Little Klappan River and Fox Creek from the project area are not expected to change this situation. The extensive system of drainage diversion channels and sediment ponds will reduce suspended solids concentrations to the B.C. Pollution Control Objective of 50 mg/l. These surface water management facilities will result in negligible impacts on stream biota in site watercourses.

In addition to the surface runoff, all other effluents from the project would be passed through the sediment and treatment ponds, or in the case of mine dry sewage, a tile field. These effluents include tailings, sewage, water drained from the plant or maintenance areas, pit water and drainage from the waste rock disposal area.

Analysis of the waste rock materials has shown that they contain an abundance of acid-consuming rock and accordingly, acid mine drainage is not expected. Trace concentrations of nitrogen will be added to the Little Klappan River due to soluble, unconsumed residuals from explosives in the waste rock. It is expected however that the levels will not exceed water quality criteria and may in fact be beneficial to the nutrient deficient system. All discharges will meet final effluent objectives and the effects on water chemistry are expected to be negligible.

While drainage patterns in the area will be altered somewhat to divert and collect runoff, the hydrology of streams downstream of the immediate project would remain essentially unaltered. The Little Klappan River would be affected by the water reservoir dam which would also become a barrier to fish upstream of the project site. There are currently limited numbers of fish in this stretch of the river. No fish were found in Fox Creek and Didene Creek. As a result, fisheries impacts are expected to be negligible.

4.4 TERRESTRIAL ENVIRONMENT

Effects on vegetation and wildlife in the project area will be localized and minimal apart from the direct loss of the land used by the project. A survey was conducted to identify rare plant species which would be affected. Fourteen species classified as rare were identified in the project area but it was also determined that these plants are not rare in the region. The impact of the Lost-Fox Mine will be limited to the loss of a few individuals but no populations of rare plants will be lost. These species occur in other locations unaffected by the development.

Impacts on vegetation due to power plant stack emissions in the form of sulphur dioxide (SO_2) concentrations or sulphur deposition are predicted to be negligible. One-hour concentrations of about 0.4 to 0.5 parts per million (ppm) have been found to cause injury to sensitive vascular plants and lichen. At Mount Klappan, the worst case maximum 1-hour concentration which would rarely occur is predicted to be about 0.03 ppm. This is less than 10 percent of the concentrations where damage could be observed in the most sensitive species.

Studies of long-term exposure of lichens to SO_2 , lichens being the most sensitive plant species, indicate that annual concentrations of about 0.01 ppm may affect lichen health. Maximum mean annual concentrations at Mount Klappan are predicted to be 0.003 ppm and this occurs in a very small area near the power plant. Virtually all other areas in the region will be exposed to levels that are less than one-tenth this maximum. Even the maximum however is far below levels where observable influences on lichen would be detected.

The predicted maximum sulphur deposition rate of 5.5 kg/ha annually is also far below levels where significant change in soil chemistry or plant vitality would occur. No aspect of power plant stack emissions has been discovered which would have other than negligible impacts on vegetation.

ENVIRONMENTAL IMPACTS AND MITIGATION

Caribou and grizzly bear are the wildlife species in the region potentially most sensitive to mine development. Extensive site investigations and radio-collar tracking studies have shown that caribou do not utilize the project area during any of the sensitive stages of their seasonal activities. There are no rutting areas, birthing sites or winter range activities in the Mount Klappan area. There is some migration through the area in the spring and late summer but no intense use of the project area and no concentrations of animals during this period. It is expected that caribou will probably simply skirt areas of mining activity during their movements through the region and overall impacts on the Spatsizi area caribou will be minimal.

Grizzly bear hunt and forage over extensive territories and have been observed in the Mount Klappan area on occasion. The grizzlies are most sensitive to disturbance during the winter and spring when they are in their dens or have new-born cubs. No denning by grizzlies has been discovered in the project area. Grizzly bear will generally avoid the project area and largely be unaffected by the development.

The basic impact on caribou, grizzly bear and other wildlife species in the project area will be the temporary loss of use of the land that the project occupies. These lands however presently represent zones of only modest wildlife utilization. They do not encompass any uniquely valuable habitat and no intense or critical use by any species has been identified.

5.0 SOCIO-ECONOMIC IMPACTS

5.1 EMPLOYMENT AND POPULATION EFFECTS

The primary social and economic effects of the project will result from the employment opportunities created and from the population increases generated in the local region. Development of the Mount Klappan Anthracite Project would result in the expenditure of more than \$250 million. The access road from the mine site to Highway 37 and the port facilities at Stewart represent an additional expenditure of \$150 million. During construction of the mine, the peak labour force would be comprised of about 450 workers. Construction of the access road would entail a peak workforce of about 525. These activities will generate over 1200 man-years of employment during the construction period of about 20 months.

Once operational, the Mount Klappan Project will employ an average of about 680 workers in full-time, permanent positions. It is also estimated that company requirements for supplies and services and demands by Gulf employees for housing, food, clothing, other consumer goods and services and government services will generate over 400 more jobs in the region. Taken together, it is expected that the Mount Klappan Project will result in over 20 000 man-years of employment during the 20-year planning horizon for the project.

Creation of these jobs will have significant effects on the social and economic development of the local region. Recent economic performance in the area has been depressed, there is high unemployment and the area has suffered through chronic boom-and-bust cycles as the fortunes of the metal mining and forest industries rise and fall. The Mount Klappan Project will provide long-term, steady employment to many area residents and it offers some measure of diversification for the local economy. Economic activity generated by the project and employees will increase the revenues of local governments as will municipal taxes. Increased levels of govern-

SOCIO-ECONOMIC IMPACTS

ment services, social amenities, commercial services and general economic development will lead to general improvement in the standard of living for all area residents.

It is expected that about 300 of the direct operating jobs associated with the project will be filled by local residents. Another 235 local residents will occupy indirect and induced employment positions. The other 556 direct, in-direct and induced jobs will probably be filled by people moving into the area from other regions of British Columbia.

Truck transport of the anthracite from the mine to the port (drivers and maintenance), management, and port loading positions will be based in Stewart. There will be about 250 jobs in these categories. In addition, a significant number of the in-migrant workers coming to the area will probably settle in Stewart. It is anticipated that a total of 560 jobs, or just over half of the projected total, will be in this community. Sixteen percent of the jobs, or about 175, will be distributed in the northern communities of Dease Lake, Telegraph Creek and Iskut. The remaining 356 positions will probably be filled by people resident in communities from Kitimat to Smithers. Kitimat, Terrace and Smithers are expected to share the largest proportion of these workers. The distribution of the jobs by community is summarized below.

As a result of these new jobs, it has been estimated that about 505 new households will be established in the region. The population increase associated with these households will be about 1450 persons. This new population will be distributed in a pattern roughly similar to the distribution of jobs outlined above except that it is expected that the in-migration will be weighted more towards Stewart than other communities. The total population increase for Stewart is projected at about 1092 persons.

Distribution of Jobs by Community

Community	Direct Employees		Indirect Jobs	Induced Jobs	Total
	Local	In-migrant			
Stewart	120	250	30	160	560
Dease Lake	20	25	-	18	63
Iskut	35	5	-	16	56
Telegraph Creek	25	5	-	16	56
Kitimat	20	25	5	20	70
Kitamaat Village	5	-	-	1	6
Terrace	25	40	35	40	140
Highway 16 Communities	15	-	-	6	21
The Hazeltons	20	-	-	8	28
Smithers	15	30	30	30	105
Total	300	380	100	311	1091

5.2 ECONOMIC EFFECTS

The economic effect of the increased incomes resulting from the project will be significant to the region. During construction of the mine facilities and access road, it is expected that local firms and individuals will earn over \$16 million. During operations, it is expected that in excess of \$32 million will be earned by direct and in-direct workers each year. Purchases by Gulf of locally obtainable supplies are projected at more than \$10 million annually.

The provincial government will also enjoy significant tax revenue increases because of the Mount Klappan Project. It has been calculated that corporate income taxes, royalties, mining taxes, sales taxes and personal income taxes attributable to the project will amount to over \$18 million

annually. Local governments will enjoy increased revenues because of increased property tax bases with the Municipality of Stewart, the Kitimat-Stikine Regional District, the Cassiar and Stewart School districts and the Regional Hospital District being the largest beneficiaries.

5.3 IMPACT MANAGEMENT

Based on the projected settlement patterns of in-migrant workers, it is anticipated that all regional communities will be able to accommodate the expected new residents. Stewart, where most of the new households will go, has ample infrastructure capacity for the projected increase. Only the northern communities of Iskut, Telegraph Creek and Dease Lake appear to be near the limits of their assimilative capacities but substantial in-migration to these areas is not anticipated.

To insure that the socio-economic effects of the project are positive for the local region to the greatest extent possible, Gulf is committed to planning the development such that opportunities for economic expansion in the region are increased, and the social difficulties sometimes associated with resource development projects are minimized and controlled. Gulf has made a substantial effort to work with residents of the region. An extensive public information and community consultation program has been conducted to advise interested groups of the project plans and to learn of the social and economic impact concerns of the residents of the region.

The Mount Klappan Project does not represent another short-term "boom" for the region. The anthracite resources at Mount Klappan can support operations far beyond the 20-year planning period and Gulf has no intention of ceasing operations at the end of 20 years if satisfactory markets are available. Should extension or expansion of the mine be considered at some future time, there will be an evaluation of the potential socio-economic and environmental impacts at that time. Ongoing consultation and communication will be continued to ensure the communities of the northwest region are fully aware of Gulf's plans.

SOCIO-ECONOMIC IMPACTS

Gulf is confident that with well considered socio-economic and human resource policies and plans, the Mount Klappan Project can make a very positive, long-term, stabilizing contribution to the social and economic well-being of the region.

6.0 OFF-SITE INFRASTRUCTURE

6.1 INTRODUCTION

The off-site infrastructure has been addressed through a Stage II Environmental and Engineering study for the access road from Highway 37 to the Mount Klappan mine site. These studies were conducted jointly by the B.C. Government and Gulf Canada Corporation and will be made available to the public as a separate set of documents.

Gulf has commissioned a series of studies on port options and a brief report is presented here.

Should a power line be constructed for electricity to supply Mount Klappan the line would follow established linear corridors where environmental impacts studies have been done previously.

The evaluation and review of the off-site infrastructure is the responsibility of the Task Force on Northwest Development while this Stage II Mine Development Submission Approval-in-Principle remains the responsibility of the Mine Development Steering Committee. Both of these groups report to the Environmental and Land-Use Committee.

6.2 ACCESS ROAD

The development of the Mount Klappan anthracite project will require the construction of a permanent road connecting the mine site with Highway 37. The selection of an alignment and the engineering and environmental evaluation of that alignment has been completed. The engineering and environmental evaluations of the selected route will be available under separate cover for public review and comment.

The selection of the access route began early in 1985 with the identification of several different corridors. Preliminary engineering and

environmental evaluations resulted in the preliminary selection of the Bell-Irving/ Konigus-Nass/Klappan route (see Figure 6-1). An alternative route, the Bell-Irving/Sweeny/Klappan route was identified in late 1985.

Comparative environmental and engineering assessments resulted in the selection of the Sweeny alternative as the most appropriate route. This route was shorter by approximately 30 km, avoided sensitive wildlife and fisheries habitat in the Nass Valley, and crossed less sensitive terrain.

The final engineering and environmental assessments focussed on the Sweeny route. The conclusions of these assessments are that there are no unacceptable environmental impacts or construction risks.

The primary environmental concern was the fisheries resource. It was concluded that potential impacts resulting from stream crossings or encroachments could be satisfactorily mitigated by appropriate design and/or construction timing constraints. An operational concern was the potential for avalanches crossing the highway right-of-way. Limited road closure may result, but it is not seen as an operational constraint.

6.3 PORT FACILITY

The port facility for the shipment of the anthracite will be located in Stewart (see Figure 6-2). There are several options for such a facility ranging from redevelopment of the existing Esso facility to the development of a new industrial port facility at Marmot Basin. No decision has been taken yet as to which of the options will be selected.

If the Esso facility is utilized, the existing location is of sufficient size that it can be developed with the area occupied by the existing mineral loading facilities. The storage facilities and the ship loading facilities would, however, require replacement and redevelopment.

The anthracite would be unloaded and stored in covered areas. This is required for both dust control and for protection from weather.

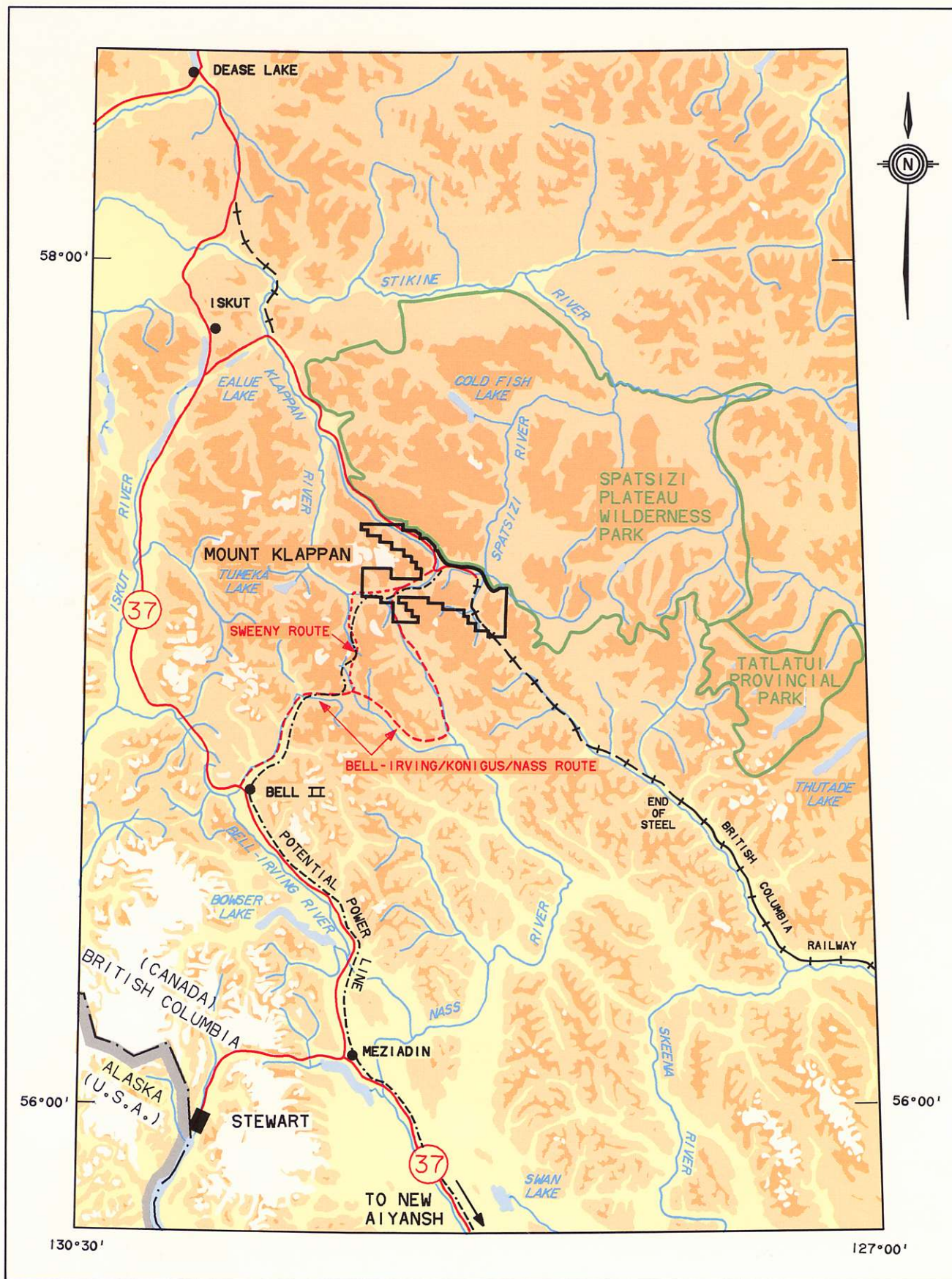



FIGURE 6-1
 GULF CANADA CORPORATION
 11/02/87



CANADA



BRITISH COLUMBIA



Aerial Photography by
MAP PRODUCTION DIVISION,
SURVEYS AND MAPPING BRANCH,
BRITISH COLUMBIA
Prepared by
GULF CANADA RESOURCES INC.

Stewart, British Columbia is an ice-free port located at the head of the Portland Canal Fjord which forms the Canada/USA Boundary. Existing facilities have been constructed to handle vessels up to 50 000 DWT. Ultimately ships of any foreseeable size may be accommodated, particularly along the south shore at Lion Point.

The Port presently handles incoming supplies for northern communities and also ships out asbestos and timber which are trucked in on all weather highways from northwest British Columbia. Stewart's future is closely tied to development in this resource rich area which also contains extensive deposits of anthracite, copper, and zinc.

PORT OF STEWART
BRITISH COLUMBIA



FIGURE 6-2

The loading conveyor would also be enclosed and of such a design that the anthracite would be lowered rather than dropped into the hold of the ship, thereby controlling dust emissions. Figure 6-3 illustrates such a system for loading.

Other port site alternatives may be considered provided they offer overall benefits more advantageous than the Esso facility.

Access to the facility is on existing roads. The Municipality of Stewart has studied the development of an industrial road that would route truck traffic away from the residential and commercial areas. The construction of such an industrial road may not be necessary. The road would be built only if benefits would accrue from doing so.

6.4 ELECTRICAL POWER SUPPLY

An on-site thermal power plant can provide both electricity and heat for the project by burning anthracite in a modern low emission circulating fluidized bed facility.

The alternative is the extension of the B.C. Hydro grid from a point near New Aiyansh to the mine site. The route for the transmission line would be within the Highway 37 corridor and the access road corridor between Bell II and the mine site. An environment assessment based on existing B.C. Hydro corridor studies and those studies done for the new access road concluded that the transmission line was environmentally acceptable. If the power line is more beneficial to the project then that alternative will be considered.

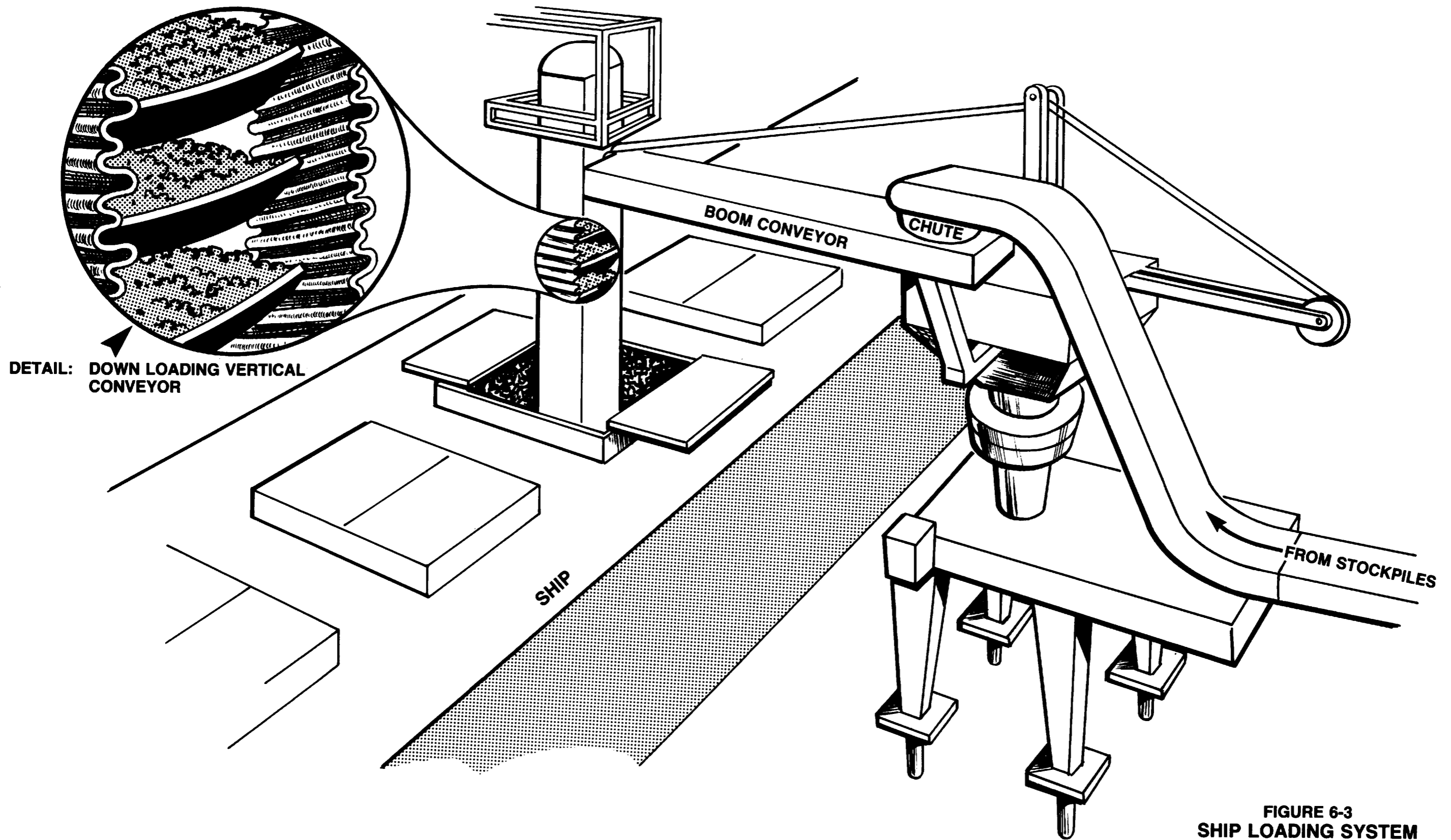

CANADA



BRITISH COLUMBIA



Aerial Photography by
MAP PRODUCTION DIVISION,
SURVEYS AND MAPPING BRANCH,
BRITISH COLUMBIA
Prepared by
GULF CANADA RESOURCES INC.

Stewart, British Columbia is an ice-free port located at the head of the Portland Canal Fjord which forms the Canada/USA Boundary. Existing facilities have been constructed to handle vessels up to 50 000 DWT. Ultimately ships of any foreseeable size may be accommodated, particularly along the south shore at Lion Point.

The Port presently handles incoming supplies for northern communities and also ships out asbestos and timber which are trucked in on all weather highways from northwest British Columbia. Stewart's future is closely tied to development in this resource rich area which also contains extensive deposits of anthracite, copper, and zinc.

PORT OF STEWART
BRITISH COLUMBIA


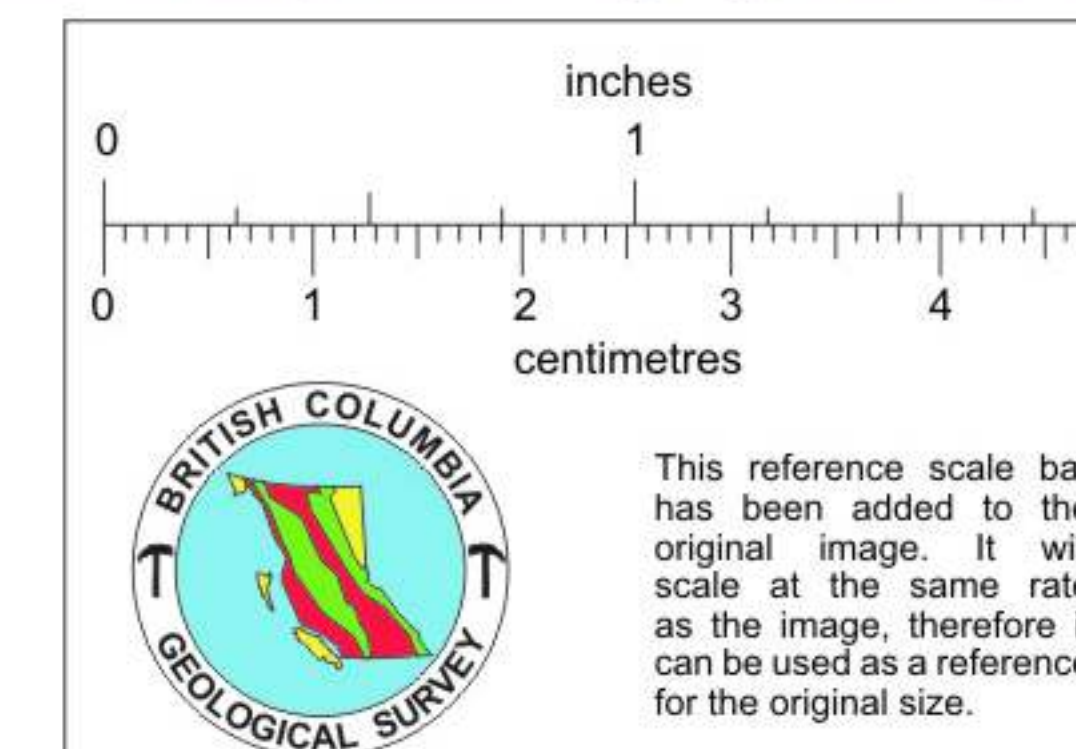

FIGURE 6-2